

# Delta Hotel and Conference Center

*Transforming spaces at the water's edge*

AR3AH115 - Revitalizing Heritage  
Reinier van Dort  
5919509



P4 PRESENTATIE



“ Heritage isn’t about what you preserve, but the meaning you give it. ”

# Heritage line Maritime Industry



# Heritage line Maritime Industry



# History of Sliedrecht

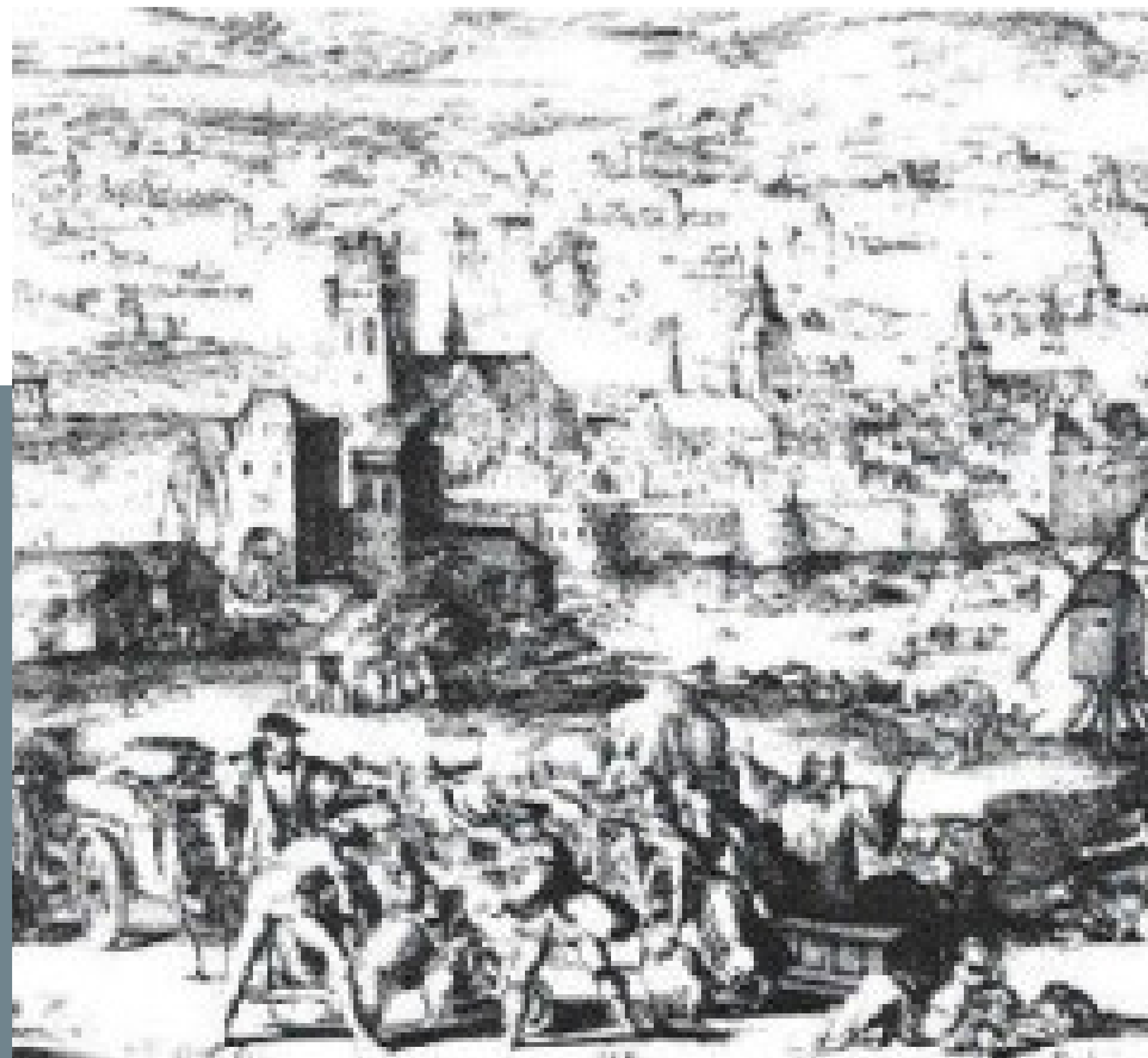

St. Elisabeth's Flood  
(Historische vereniging Sliedrecht, 2025)



Sliedrecht north and south of Merwede  
(Historische vereniging Sliedrecht, 2025)

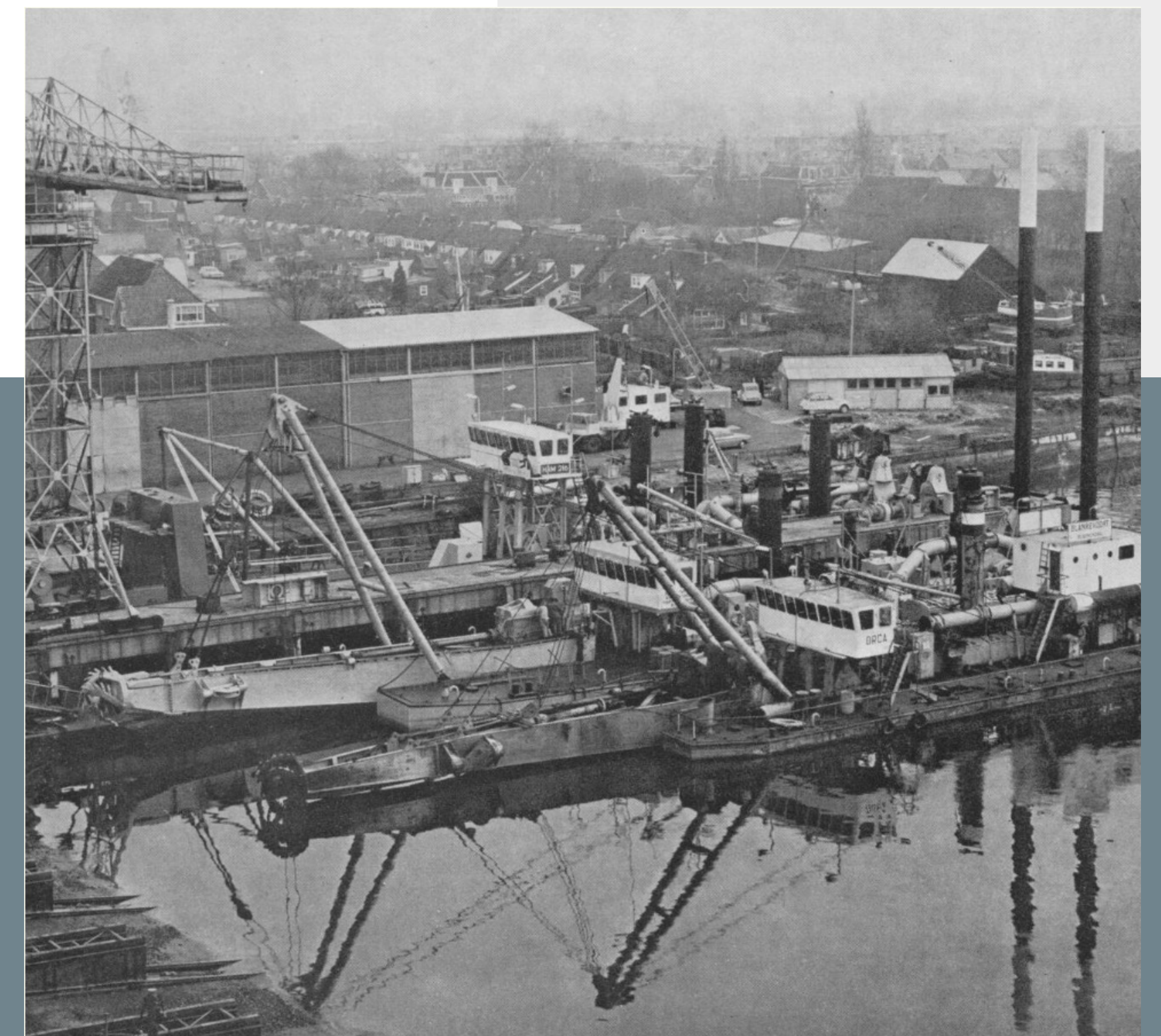

Dredging ships  
(Historische vereniging Sliedrecht, 2025)

1850



1850-1900

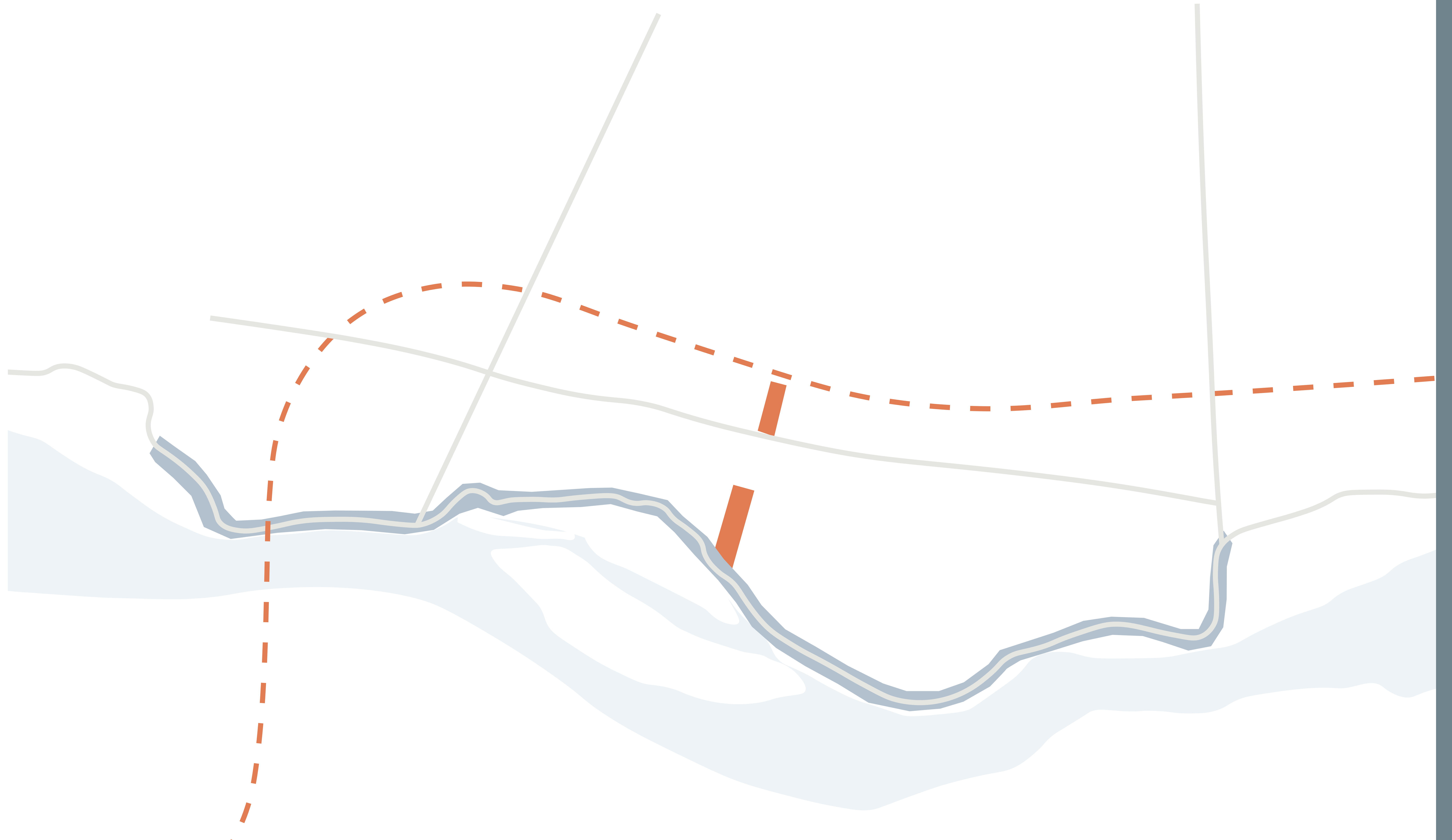

# 1900-1950

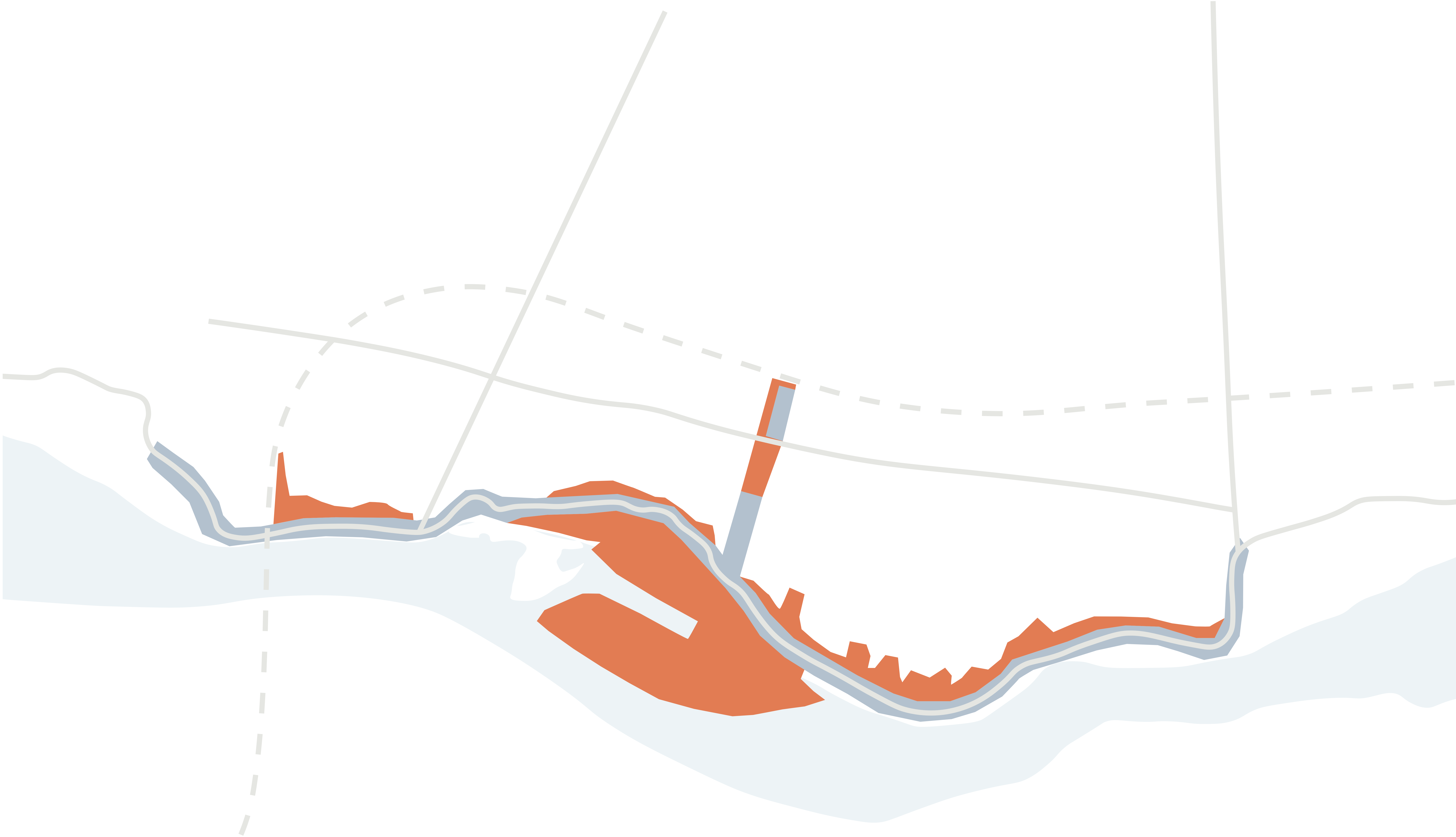

1950-1960

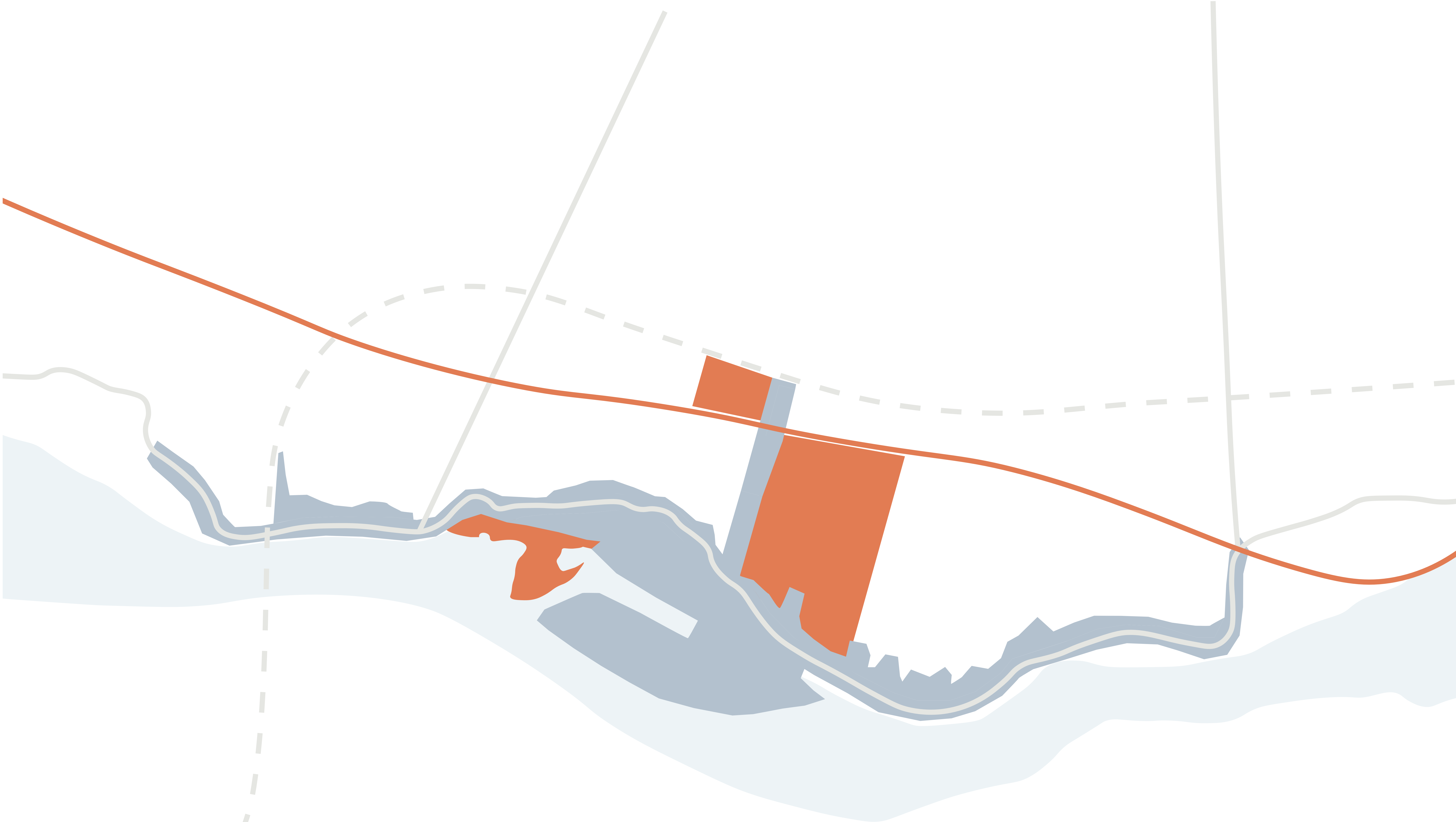

1960-1970

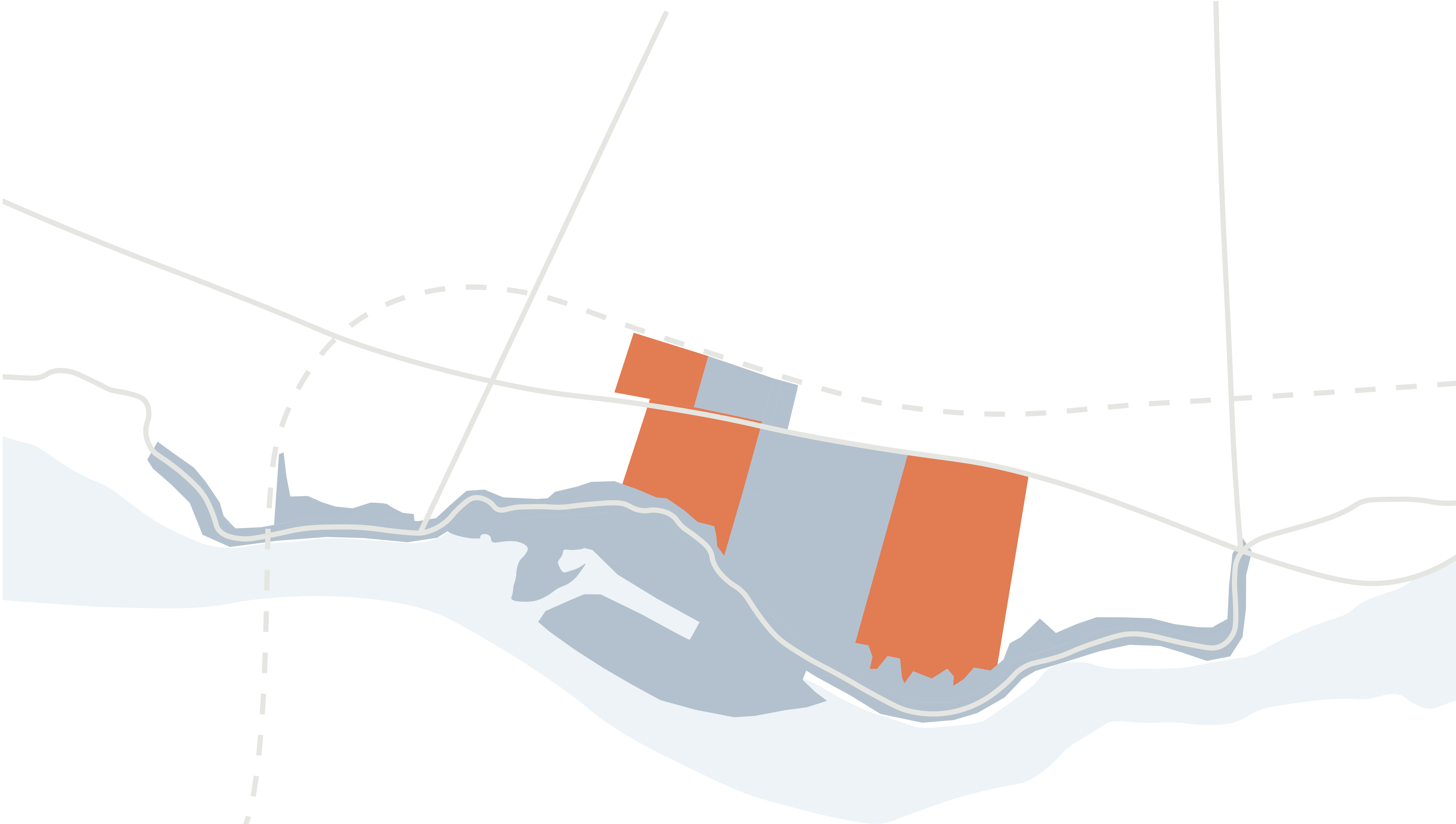

1970-1980

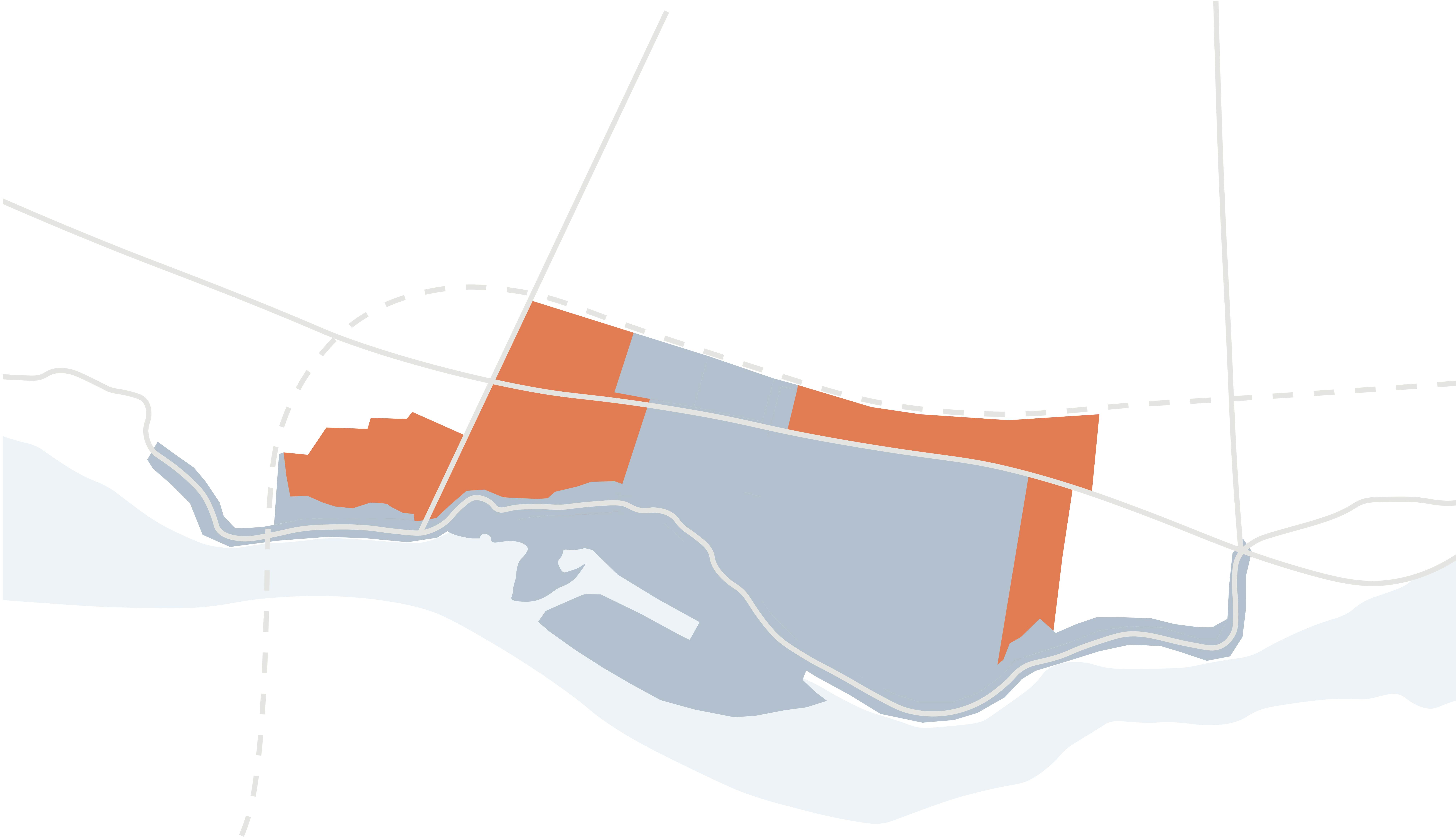

1980-1990

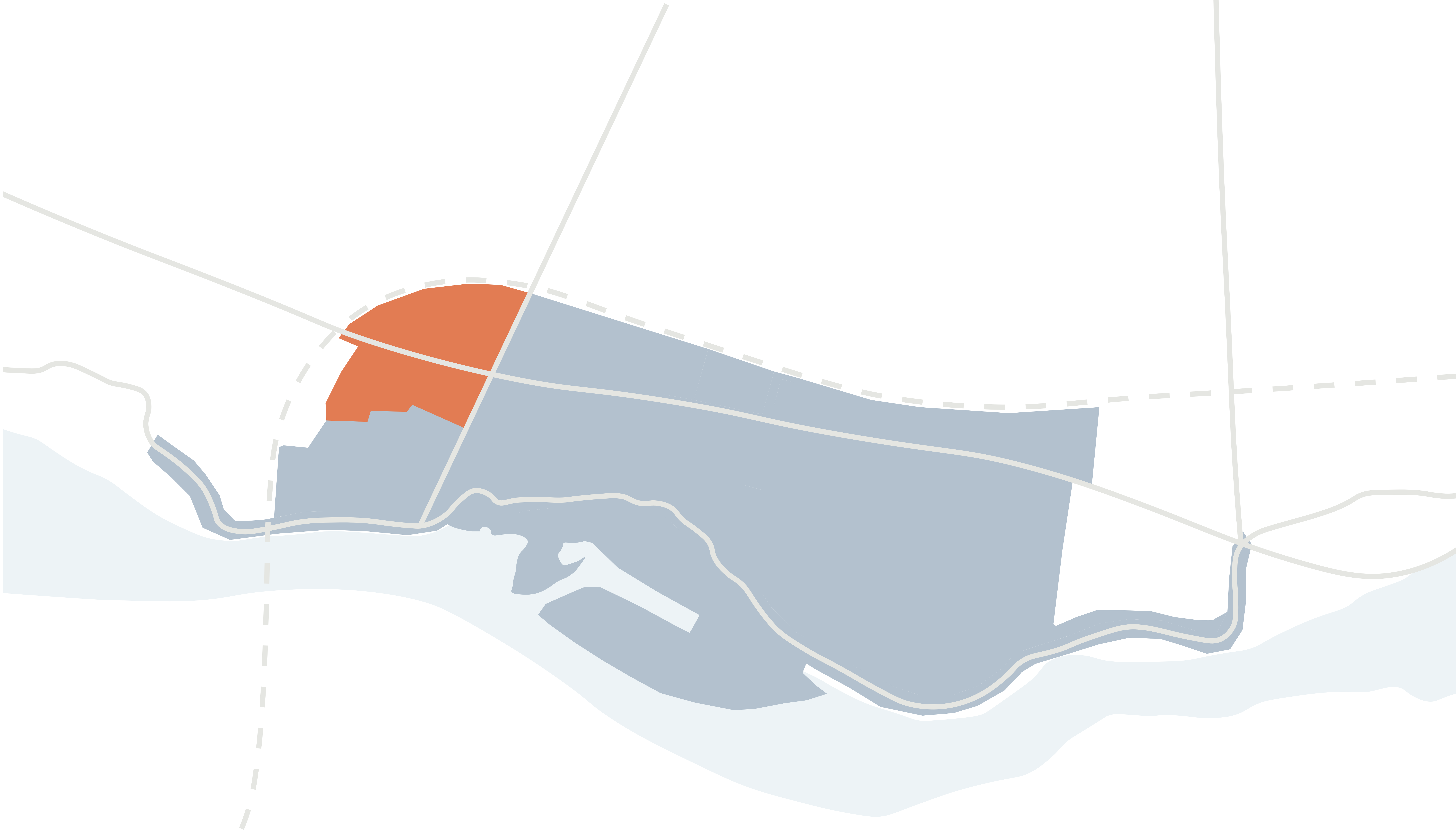

1990-2000

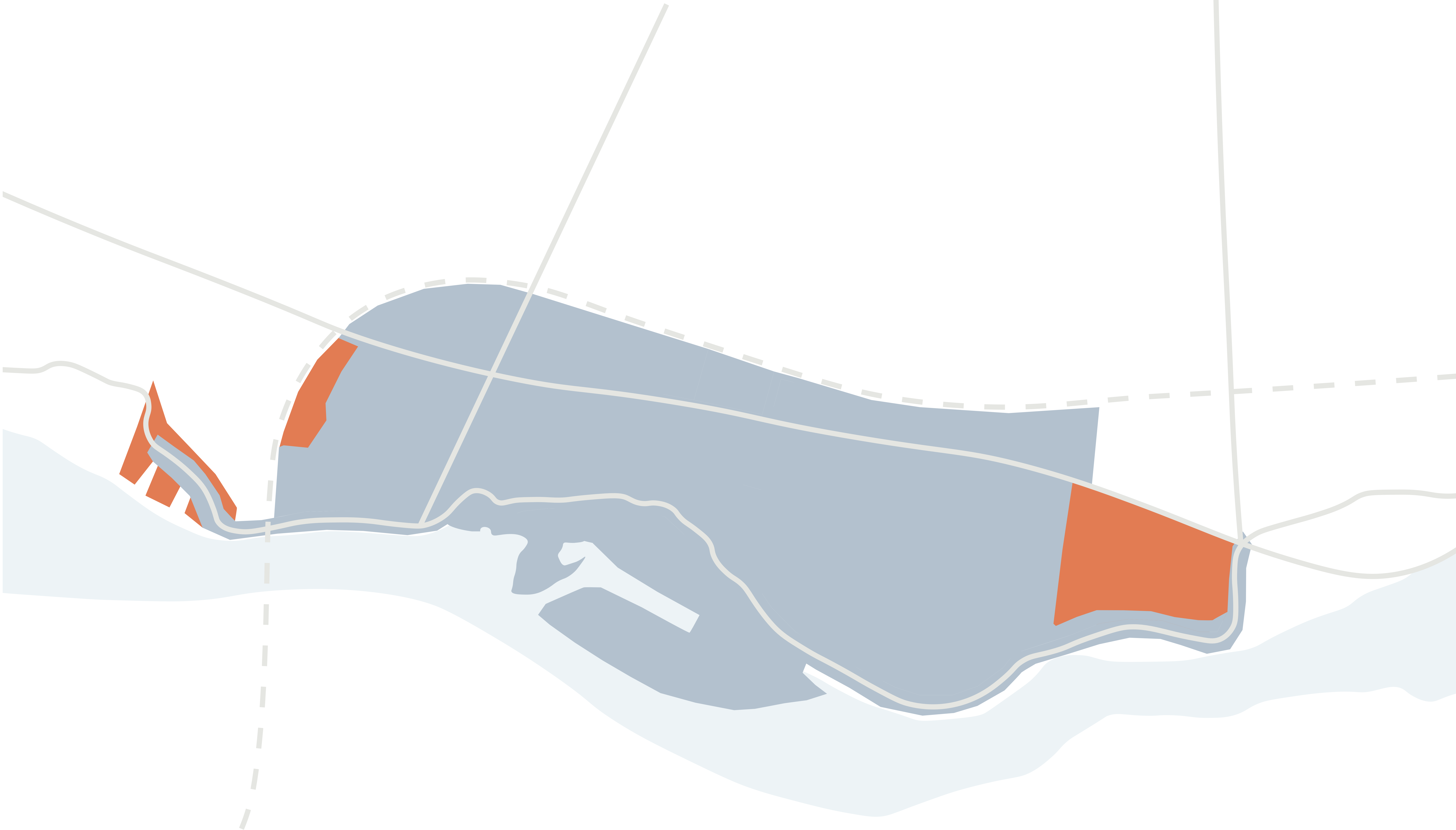

2000-2010

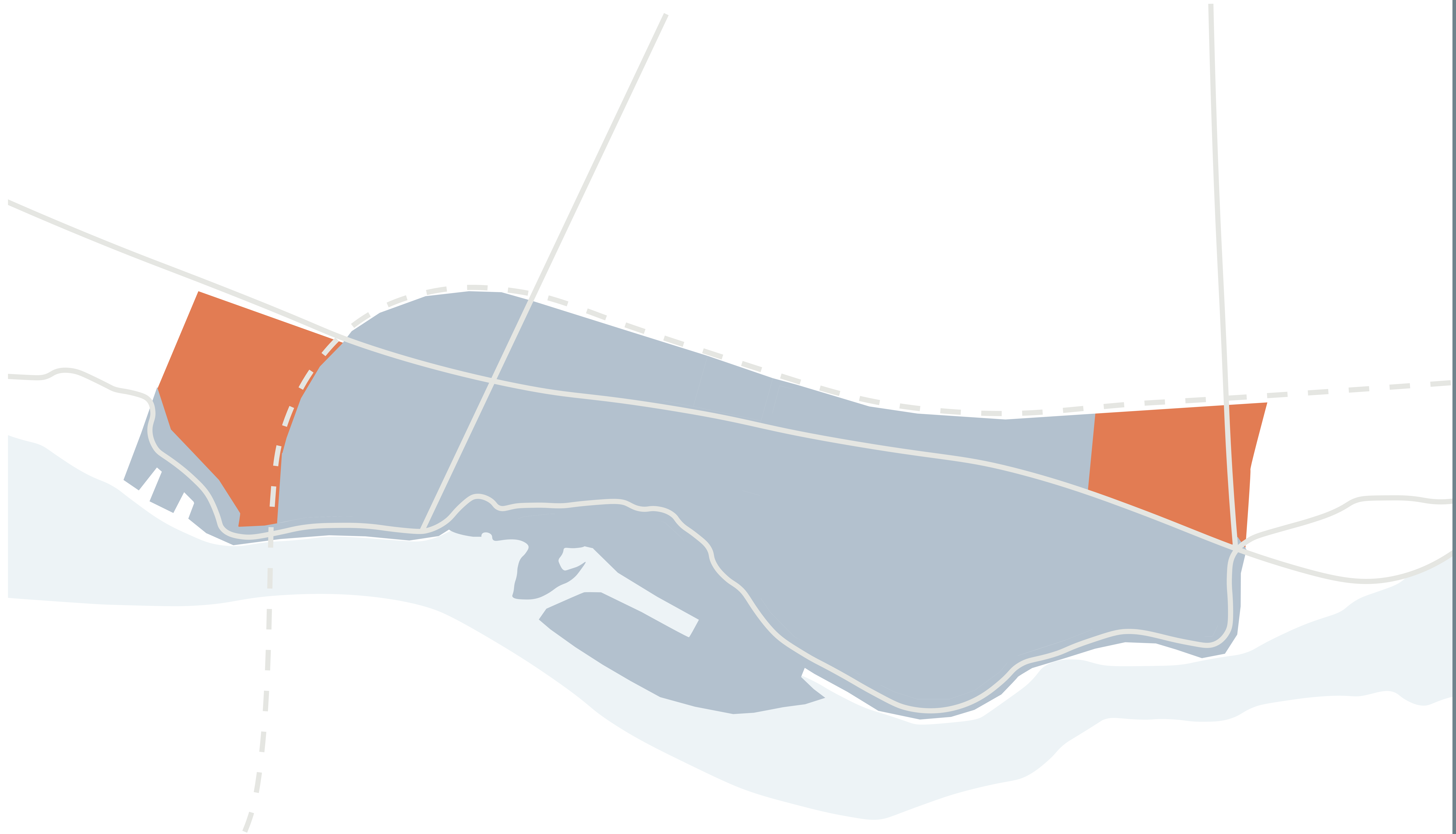

2020





1886

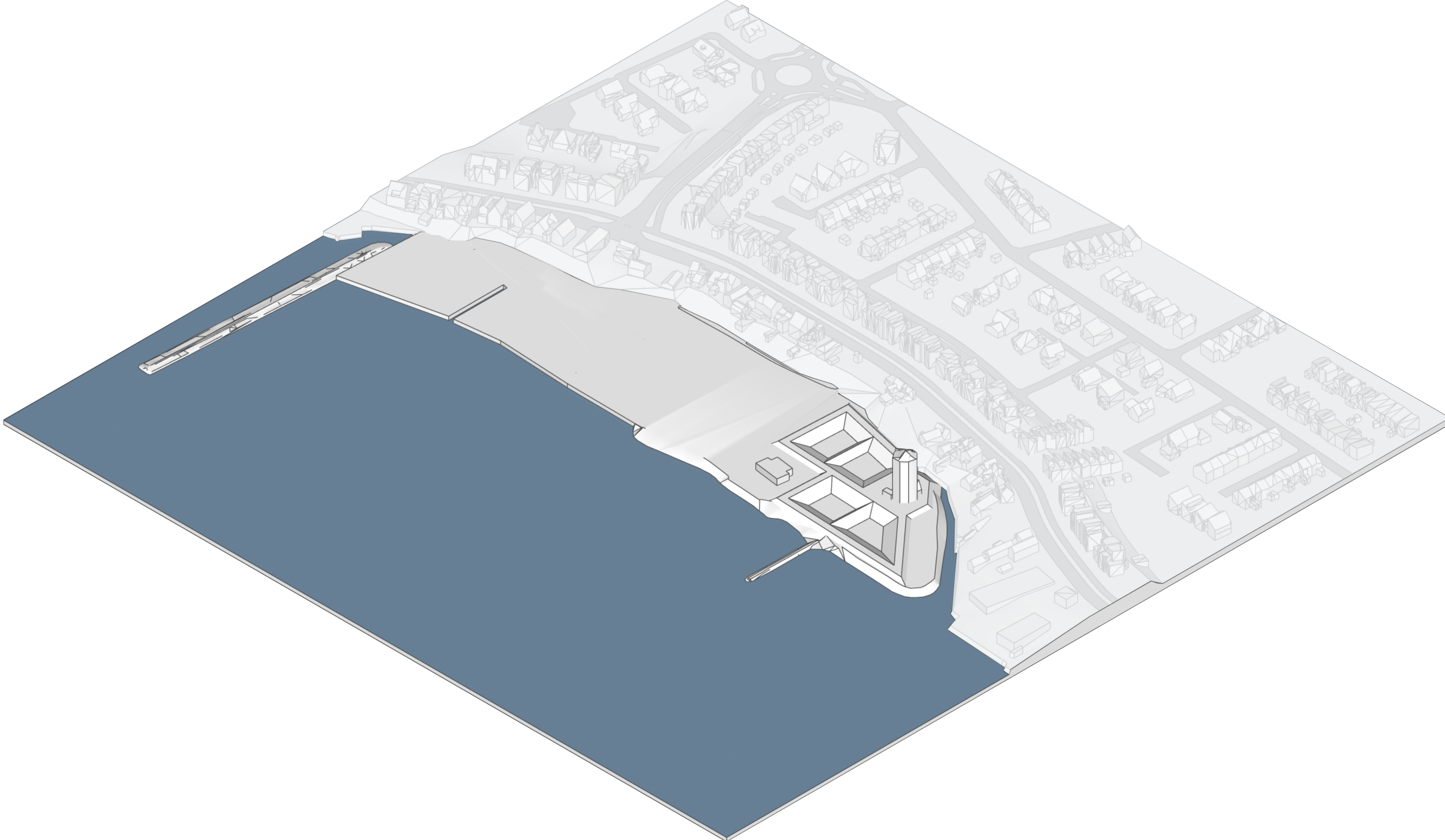

1950

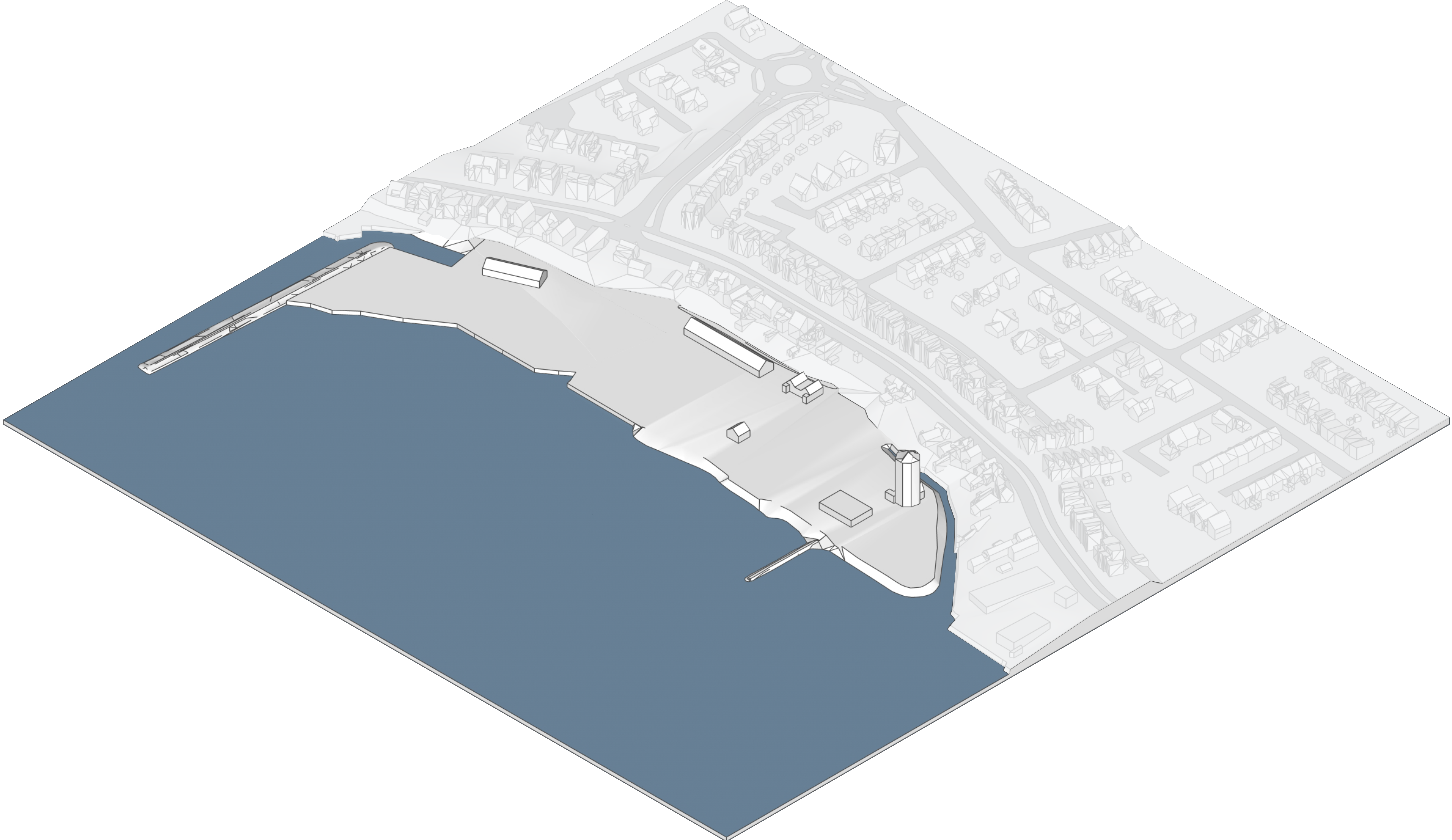

1960

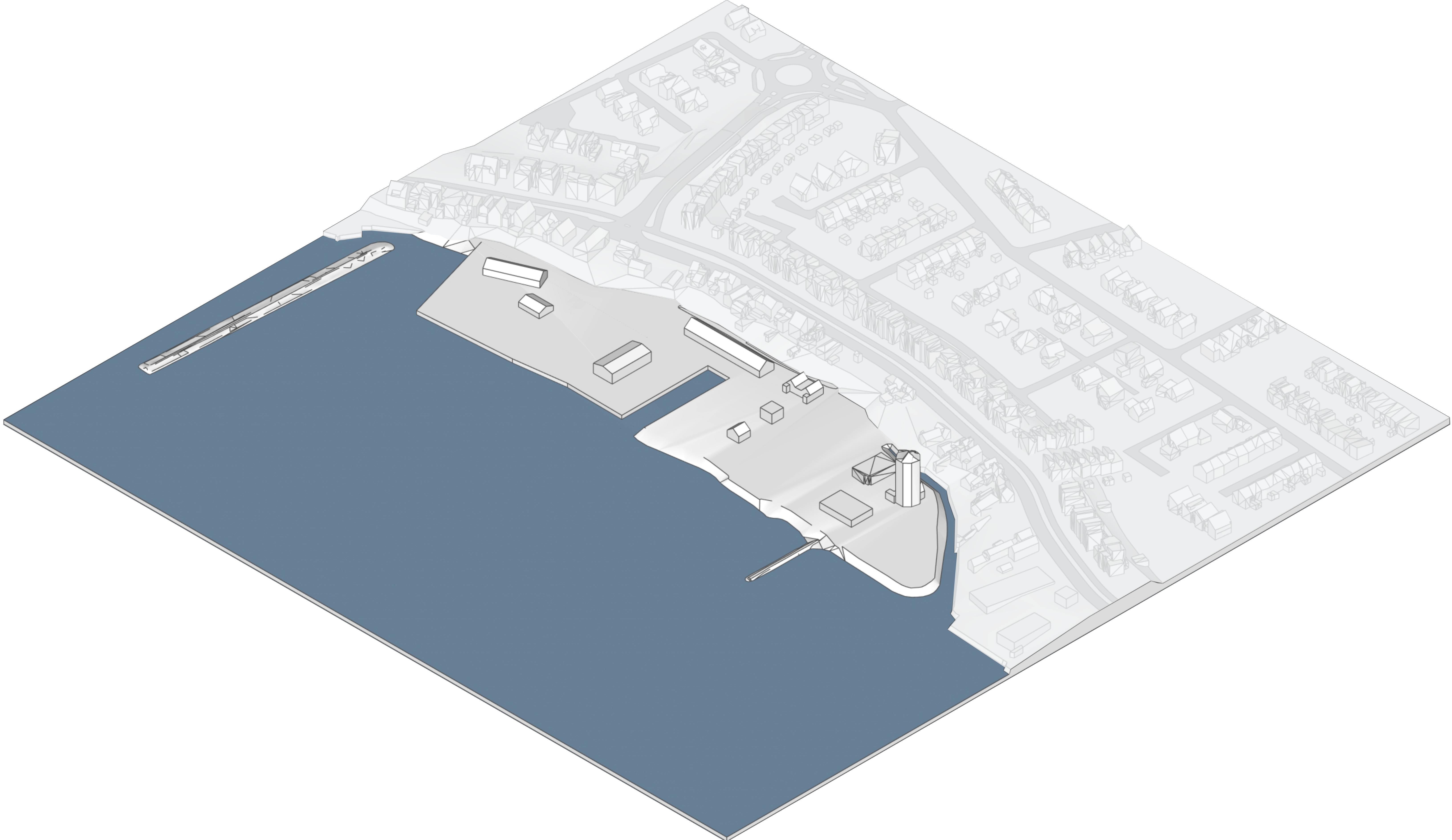

1970

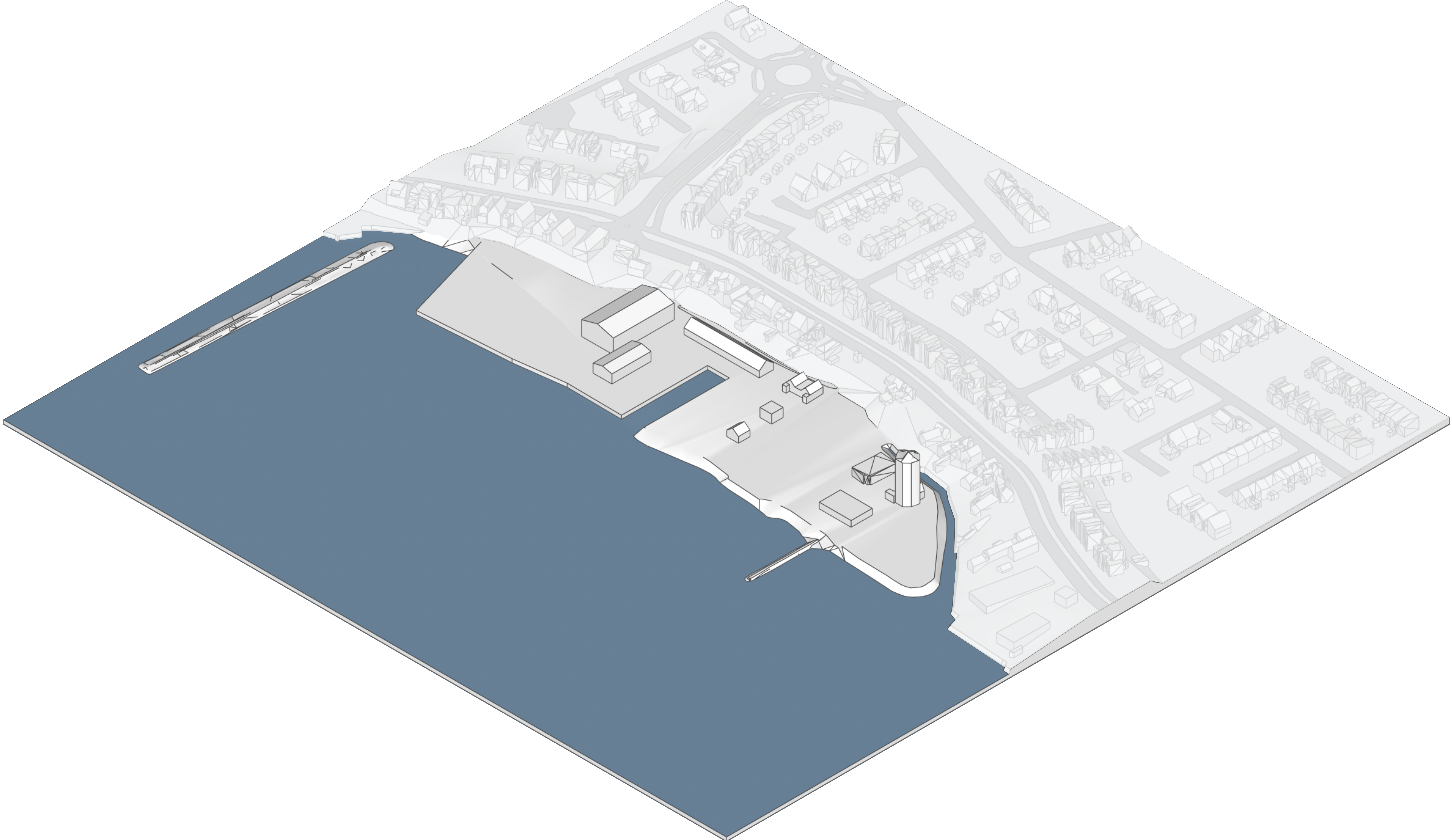

1980

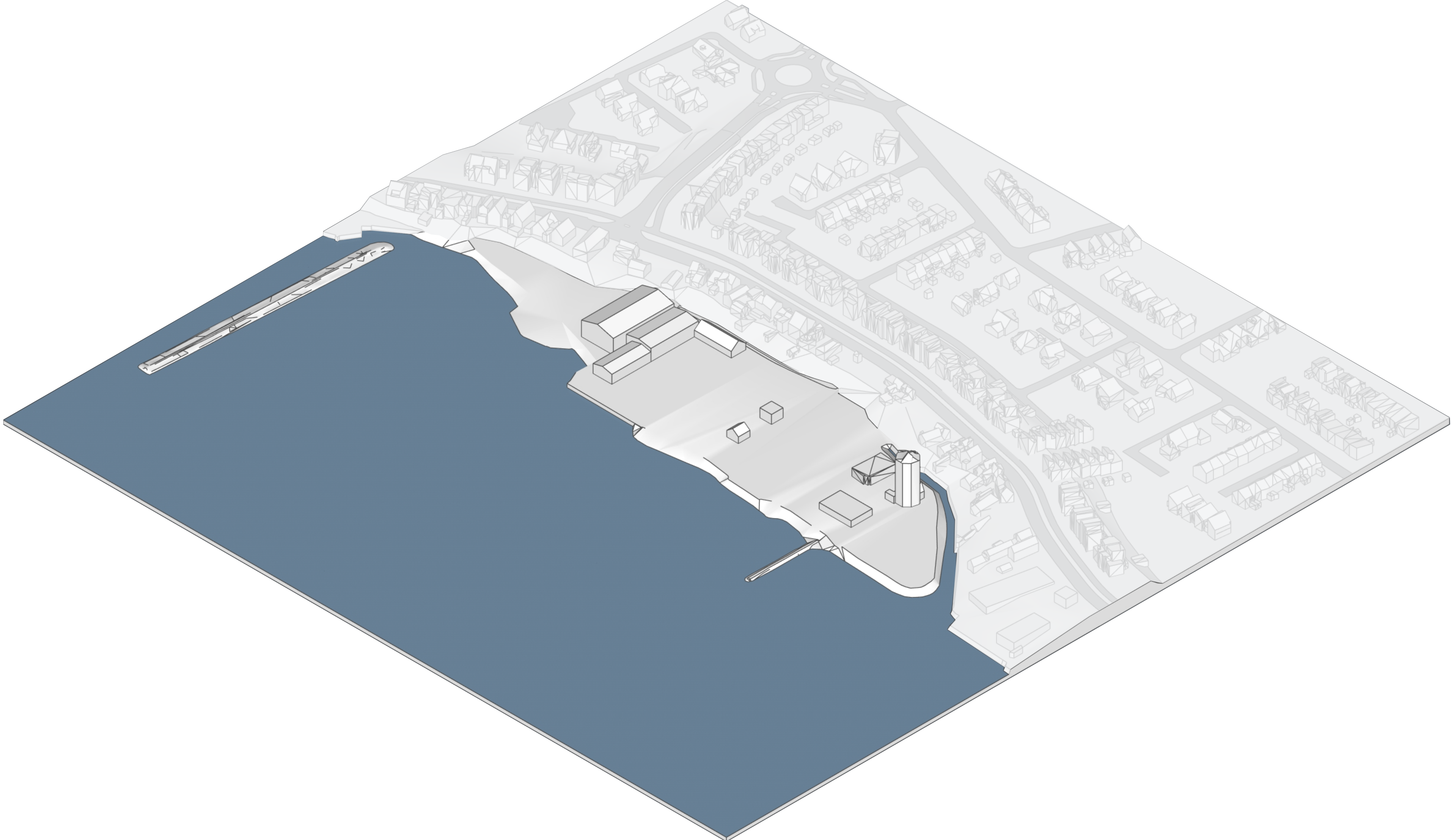

1990

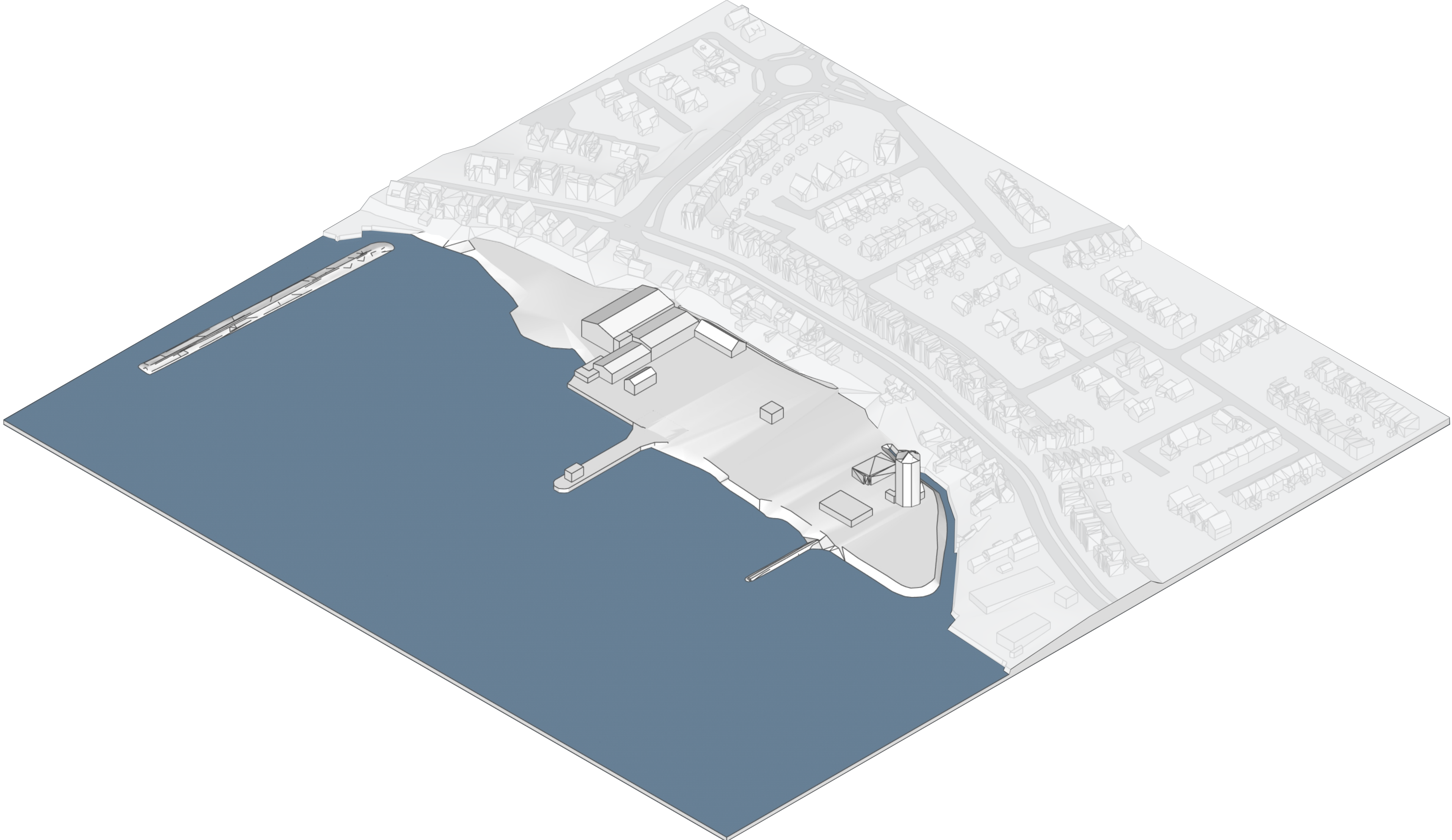

2025

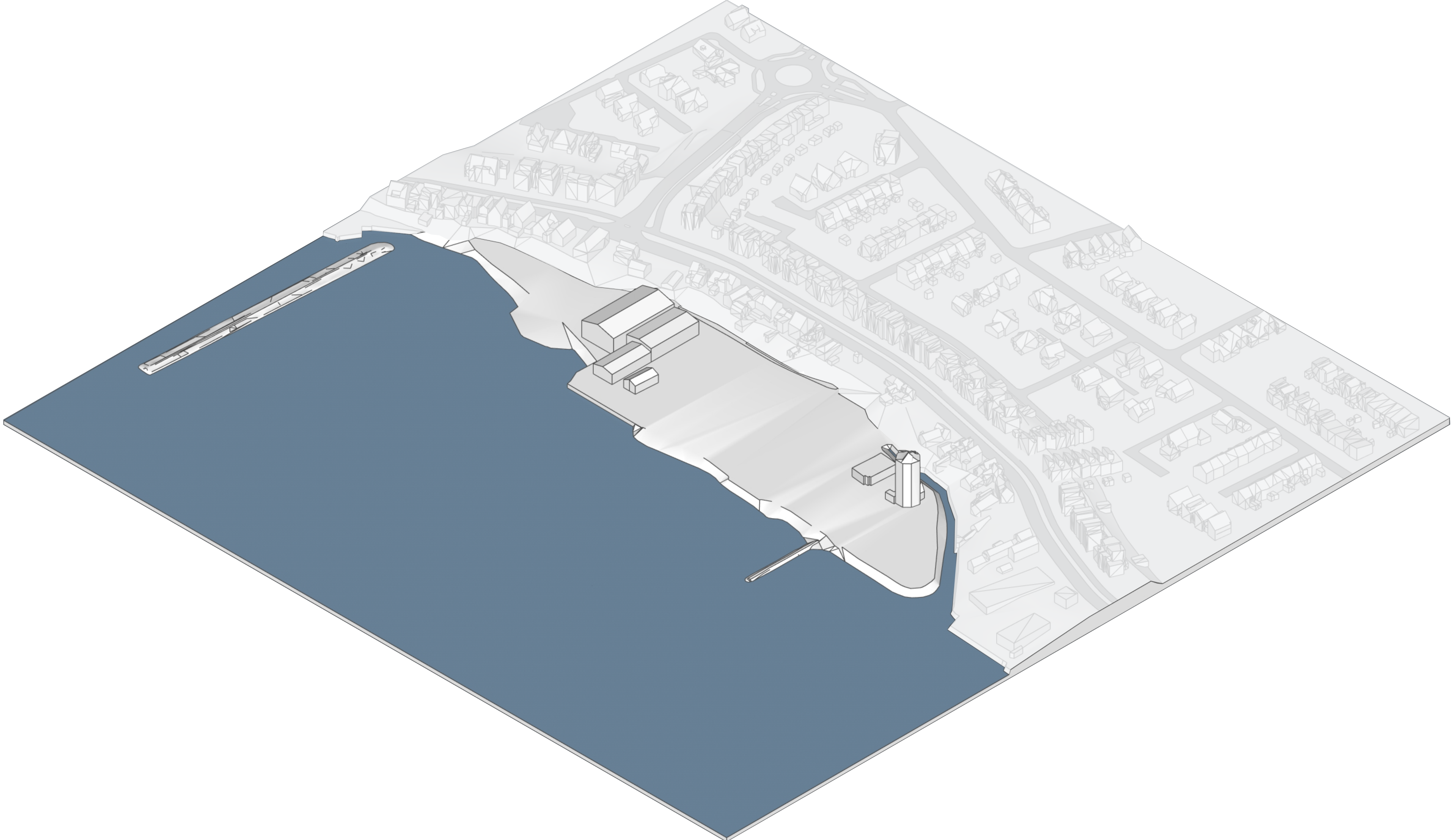



Aerial view of Water Tower Area. (Google Earth, 2025)

## Ruimtelijke vernieuwing

### 3.1.1 Woningbouw



## Ruimtelijke vernieuwing

### 3.1.2 Ruimtelijke kwaliteit: historisch, groen en adaptief





Historical  
value

# Outer dike areas

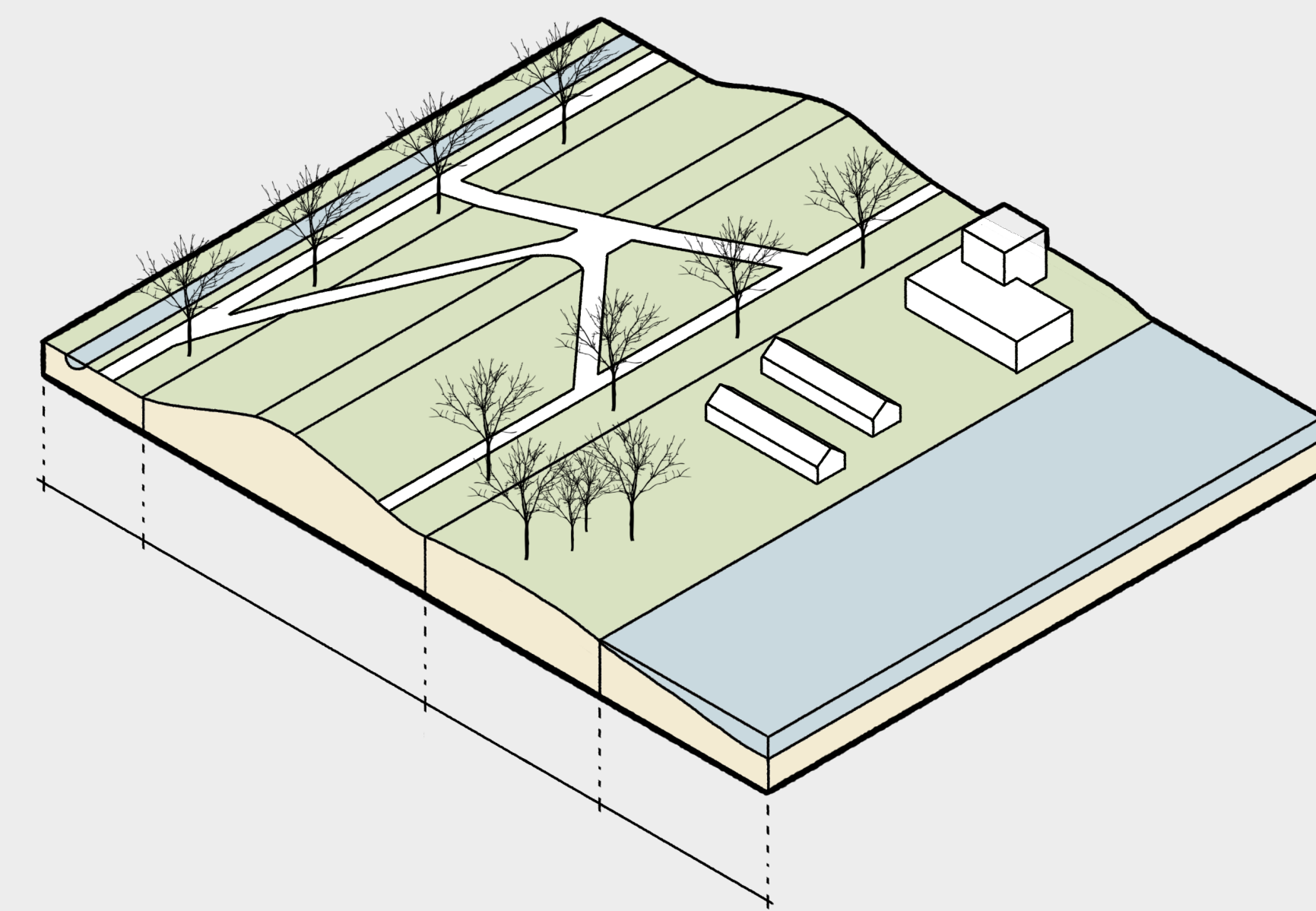

Outer dike area

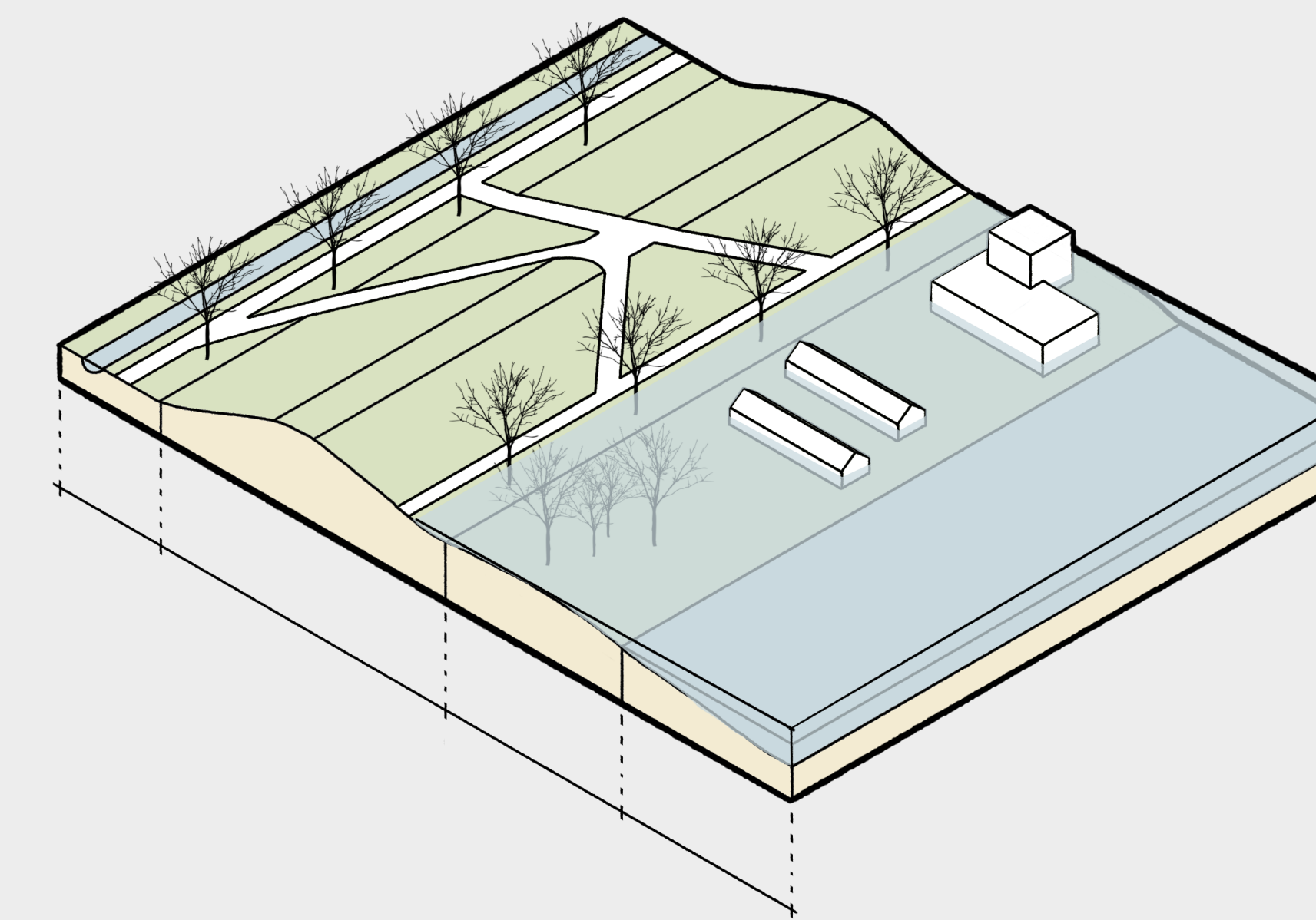

Outer dike area  
flooded

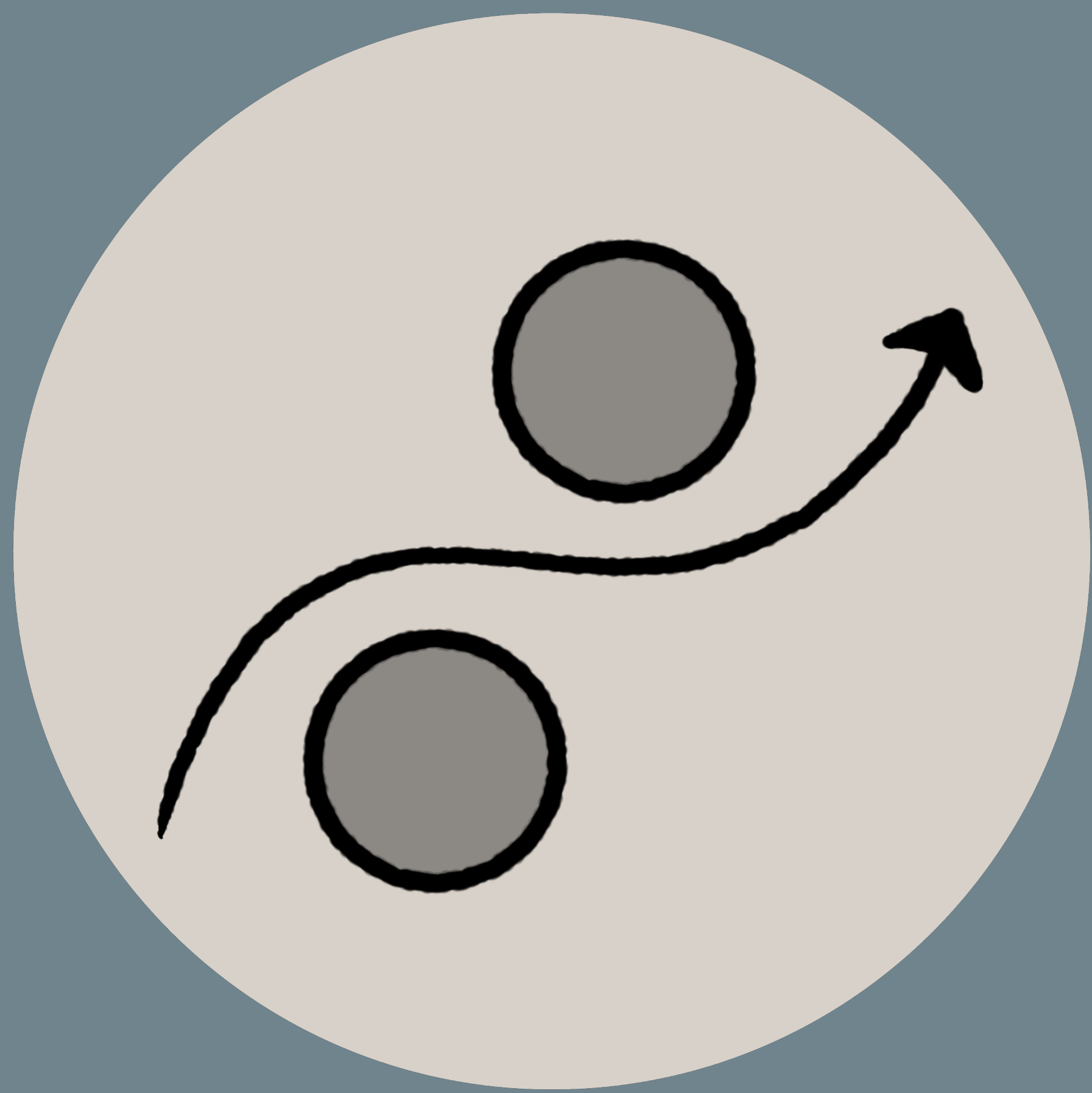

Avoidance

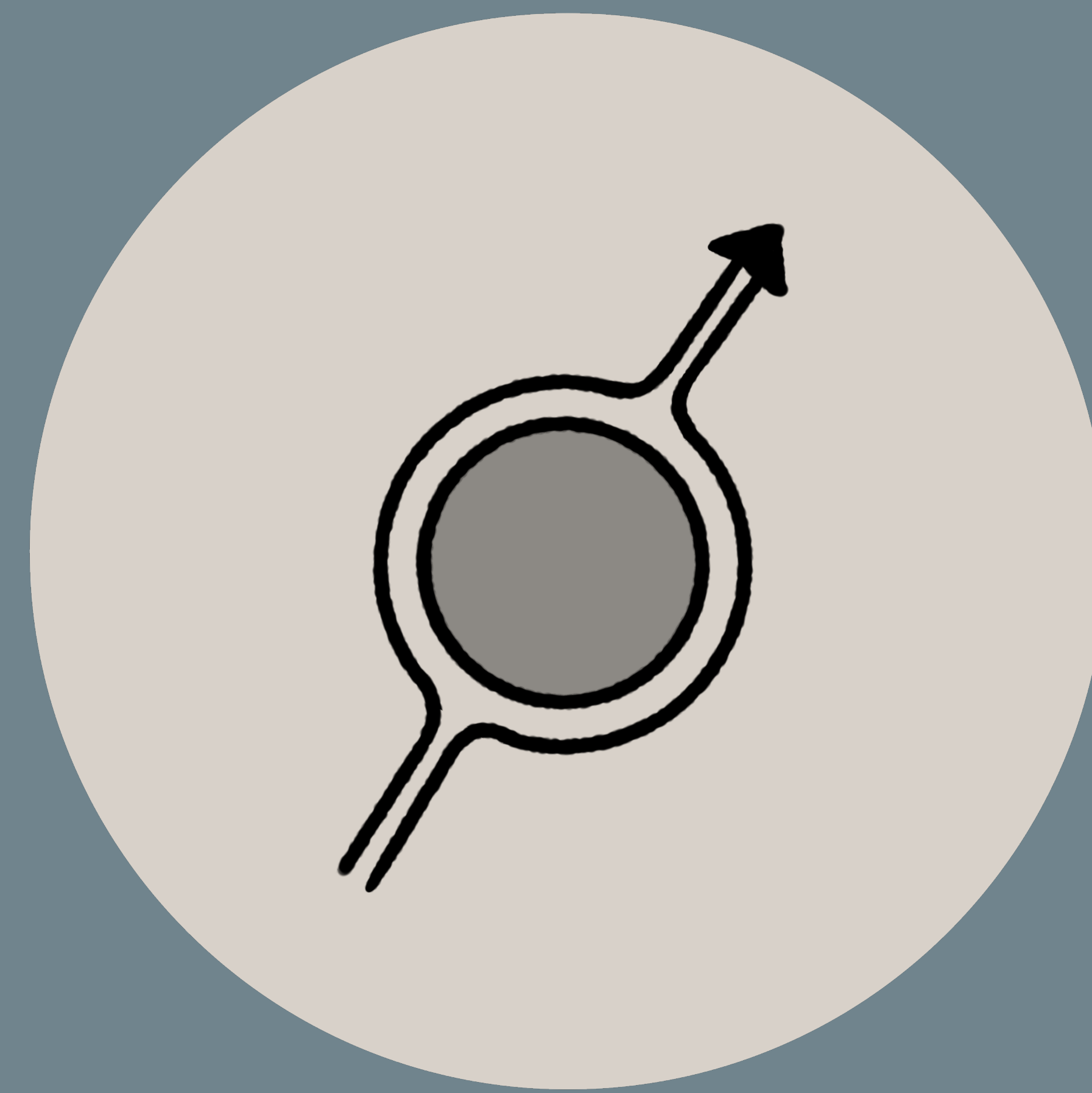

Exclusion



Allowance

# Flood risk

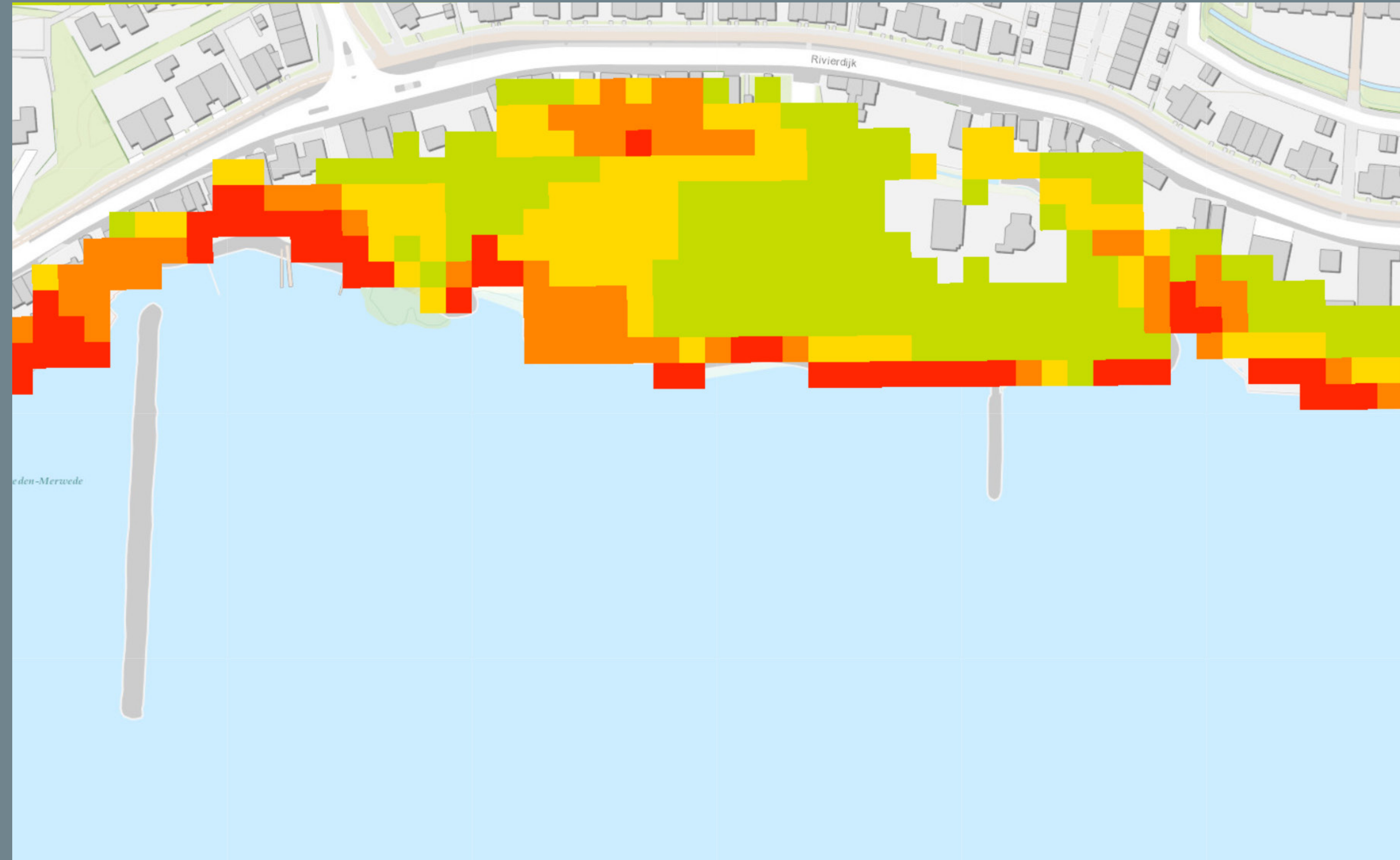

Flood risk 20cm (Stichting Climate Adaptation Services, n.d.)

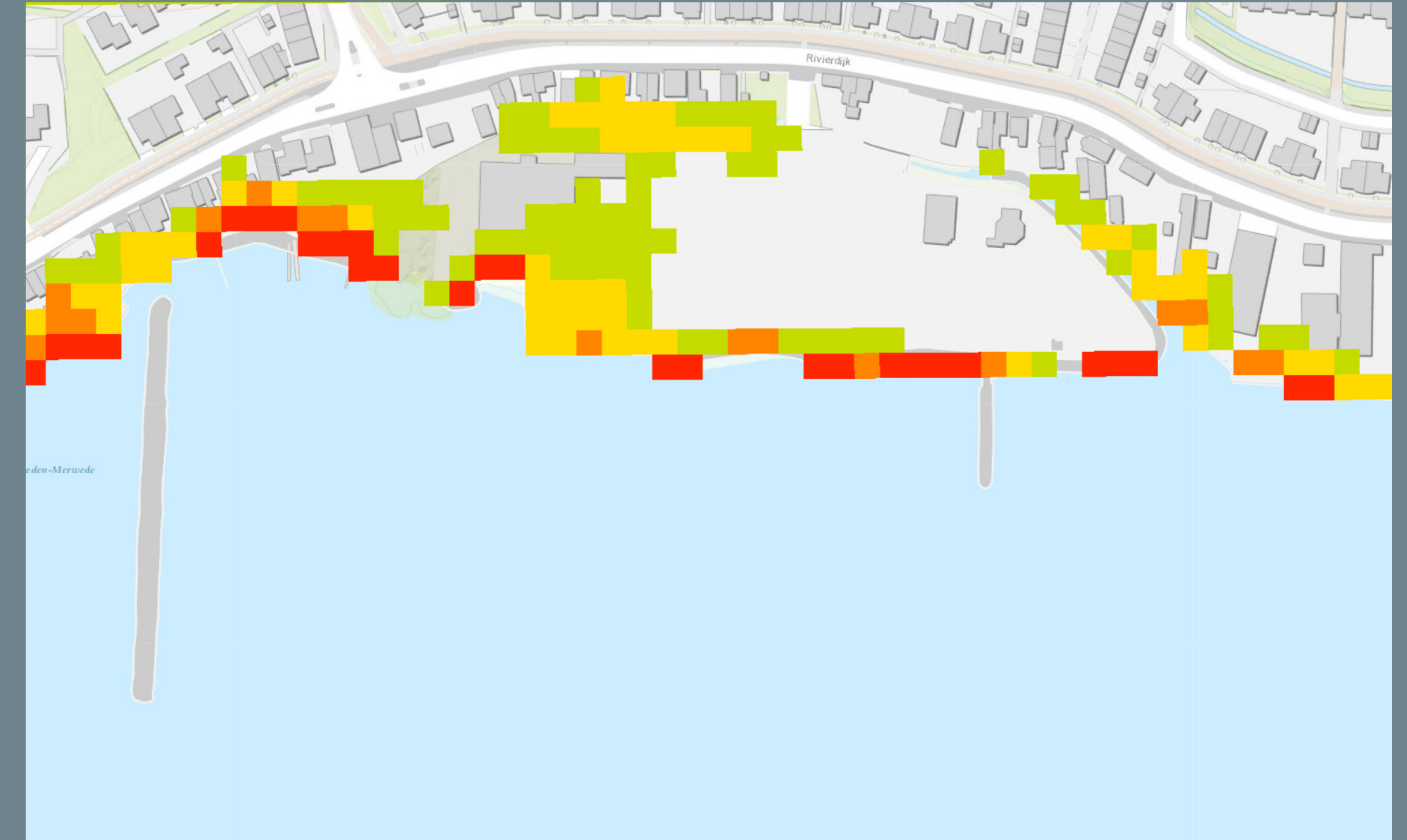

Flood risk 50cm (Stichting Climate Adaptation Services, n.d.)

- No significant flood risk
- Extreme low chance:  $<1/30.000$  years
- Very low chance:  $1/3.000$  to  $1/30.000$  years
- Low chance:  $1/300$  to  $1/3.000$  years
- Moderate chance:  $1/30$  to  $1/300$  years
- High chance:  $>1/30$  years

1. A housing development task,  
driven by municipal goals

2. A more green and accessible  
waterfront

3. The need to preserve and  
reuse heritage

4. A potential flood risk that  
influences design decisions

# Master plan

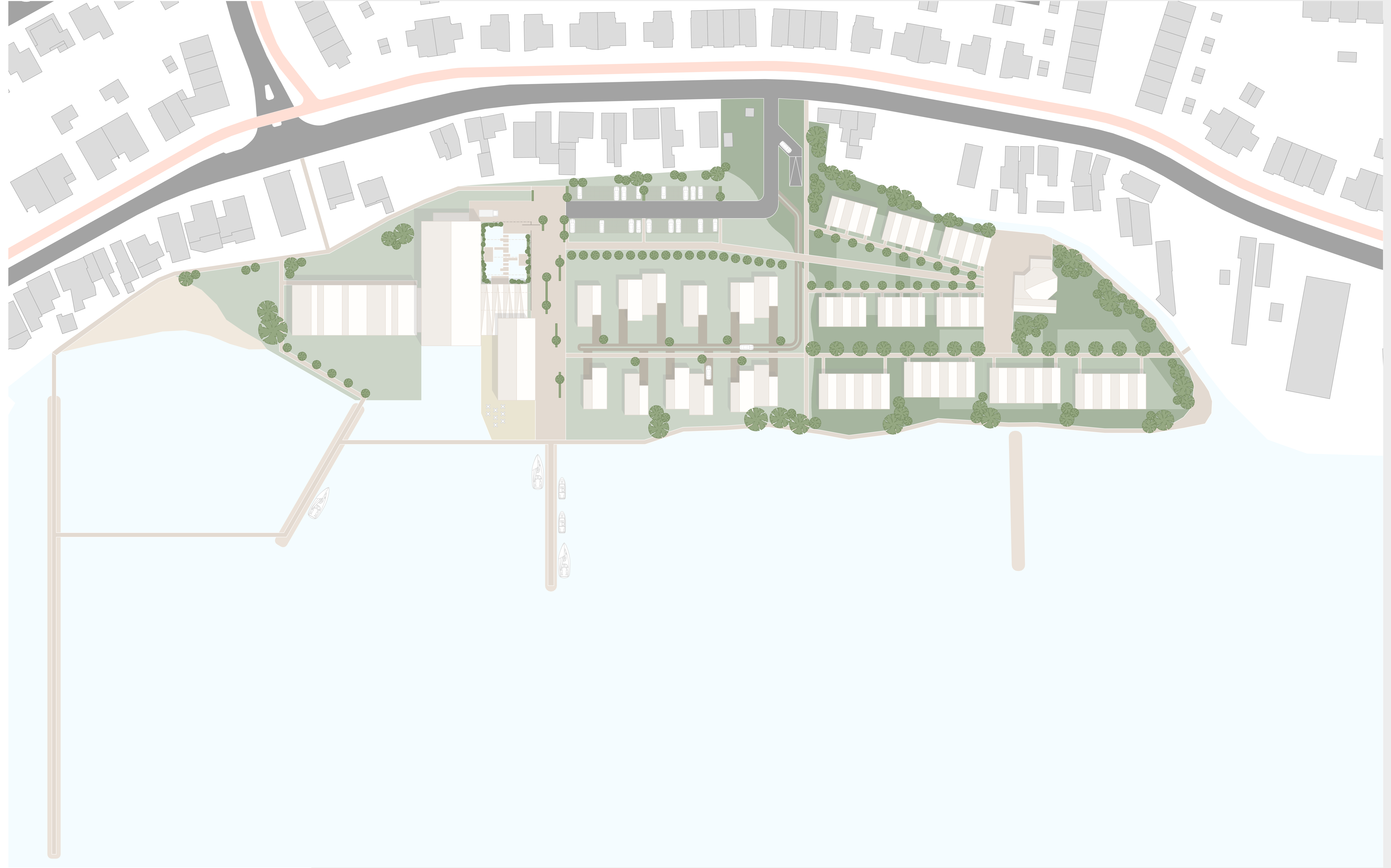

Master plan

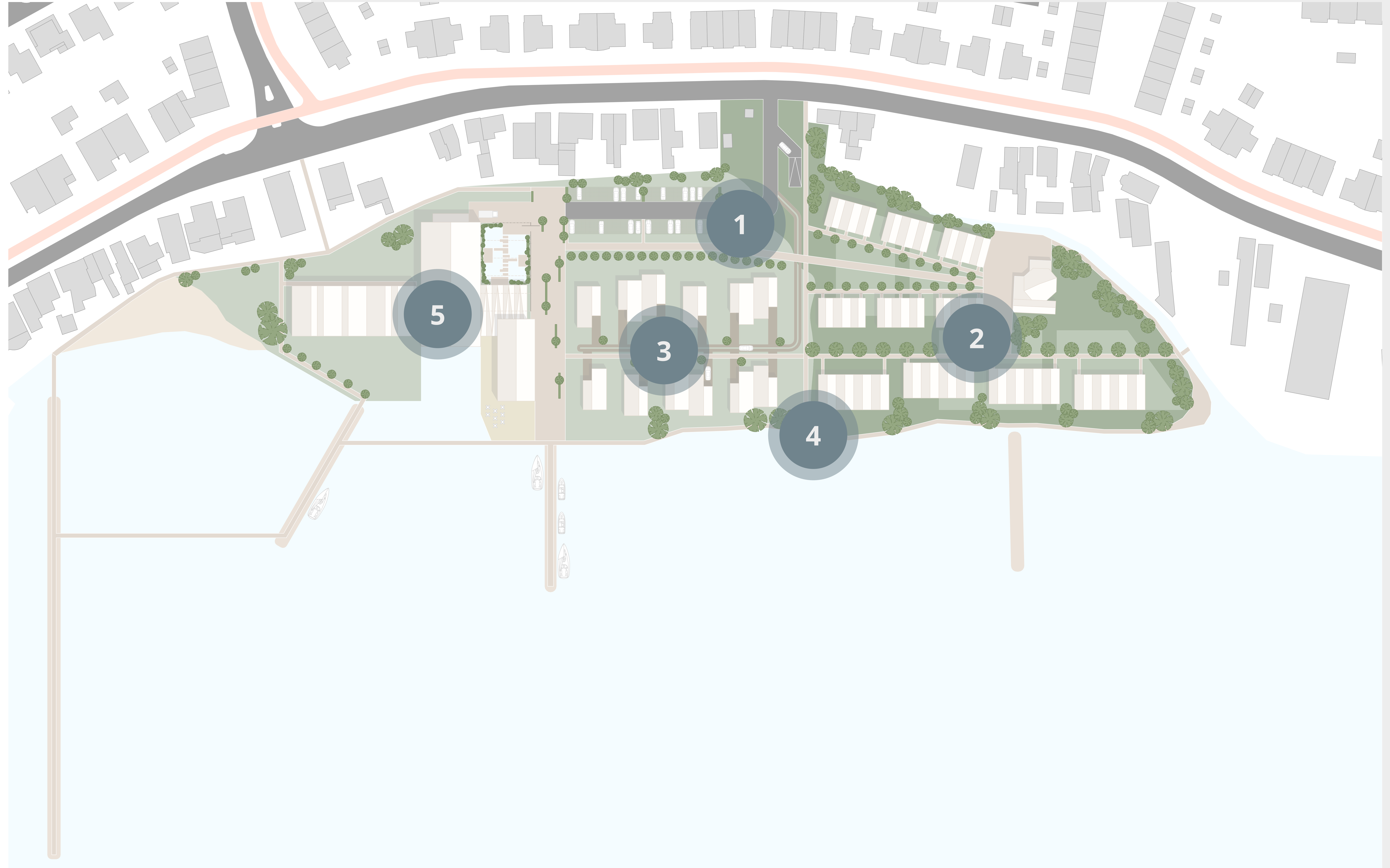

Master plan

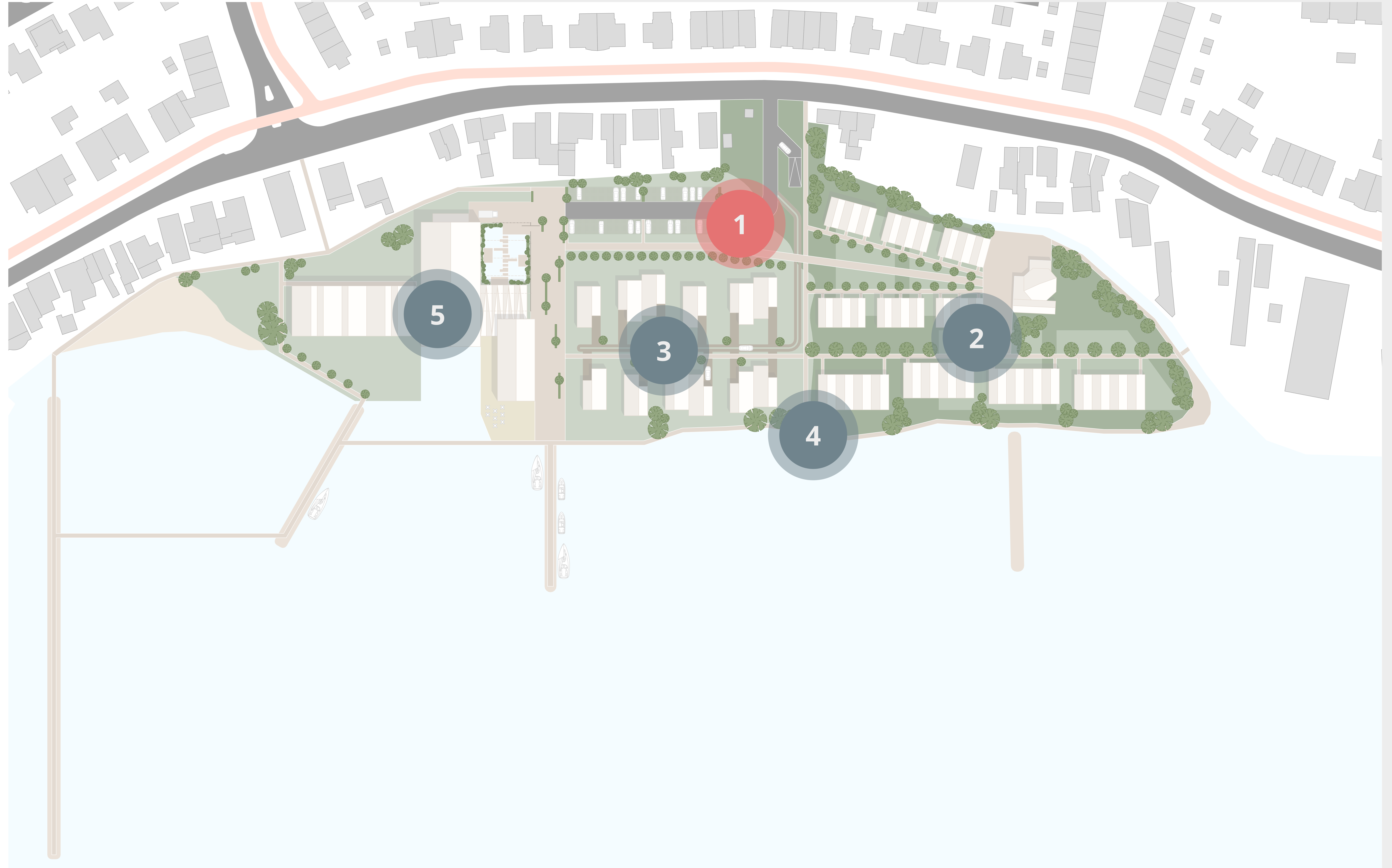

# Master plan

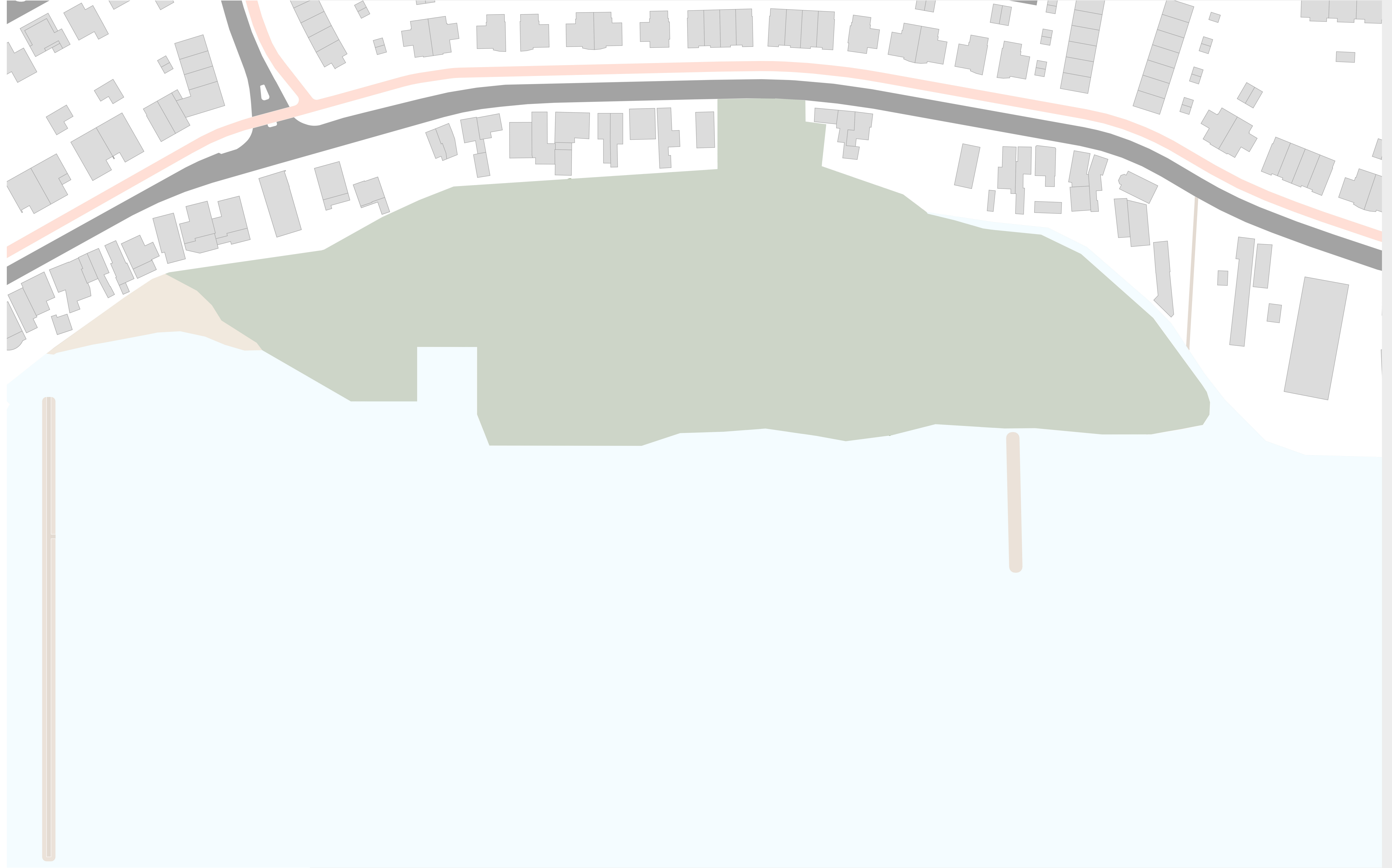

Master plan

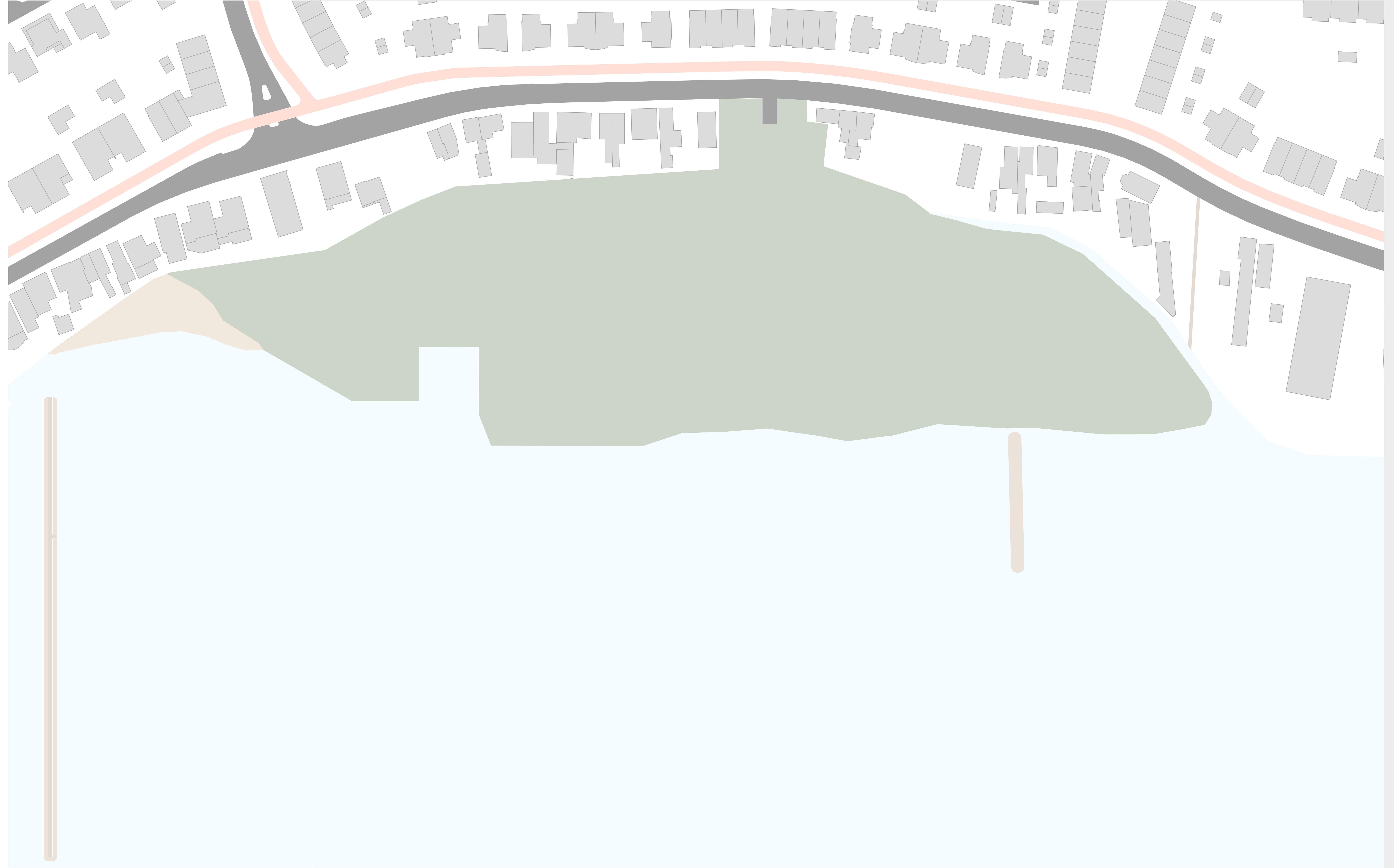

Master plan

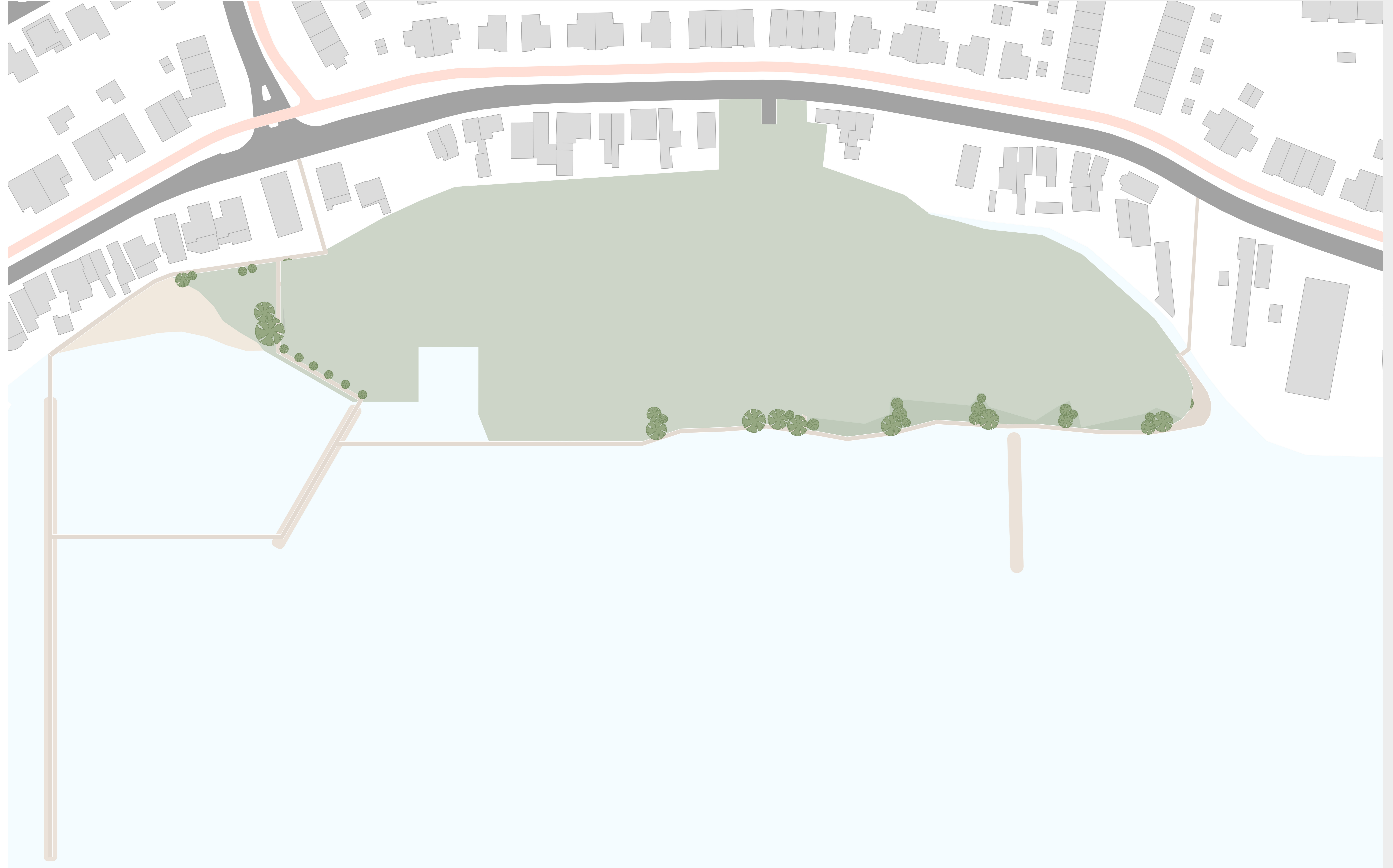

Master plan

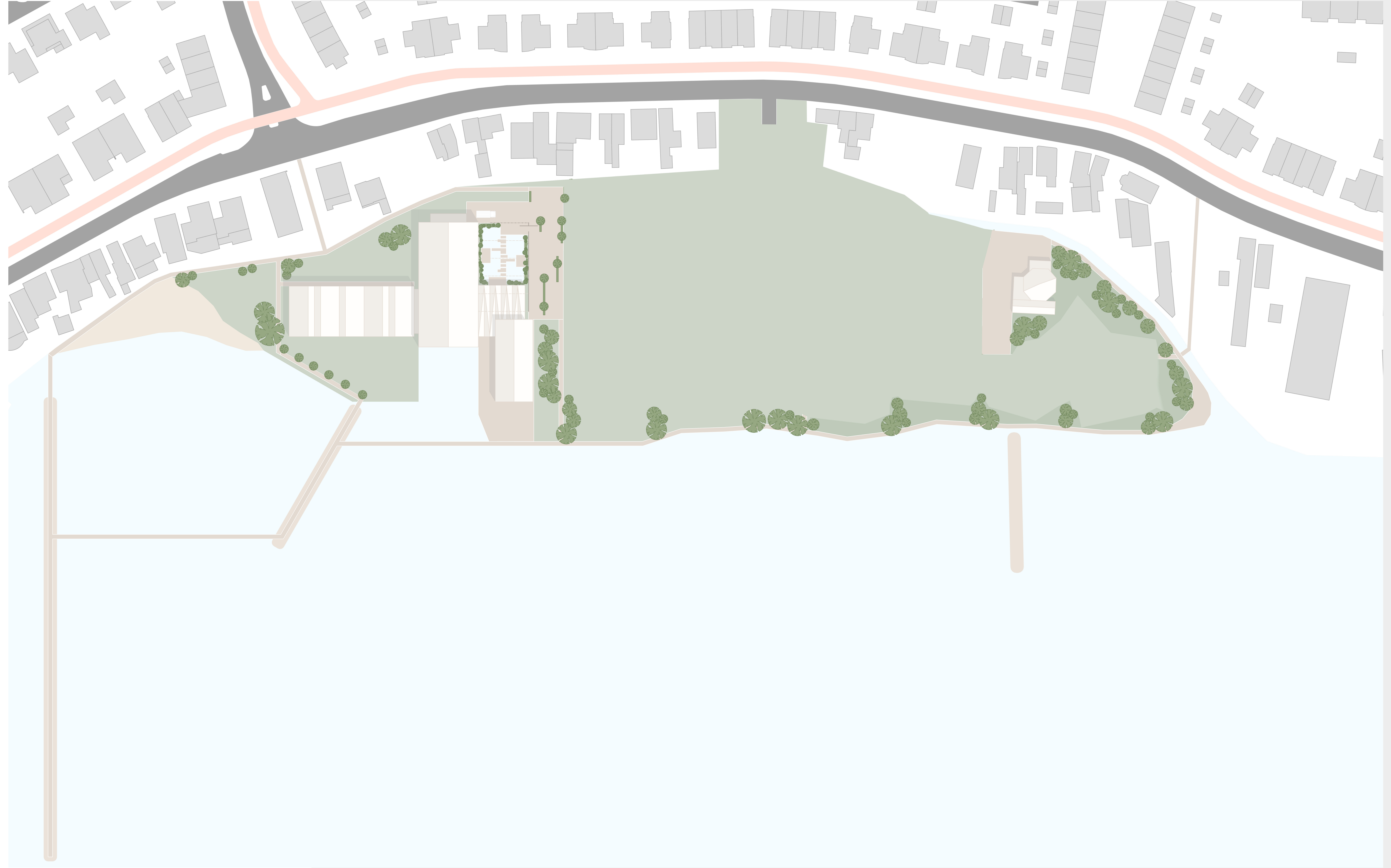

# Master plan

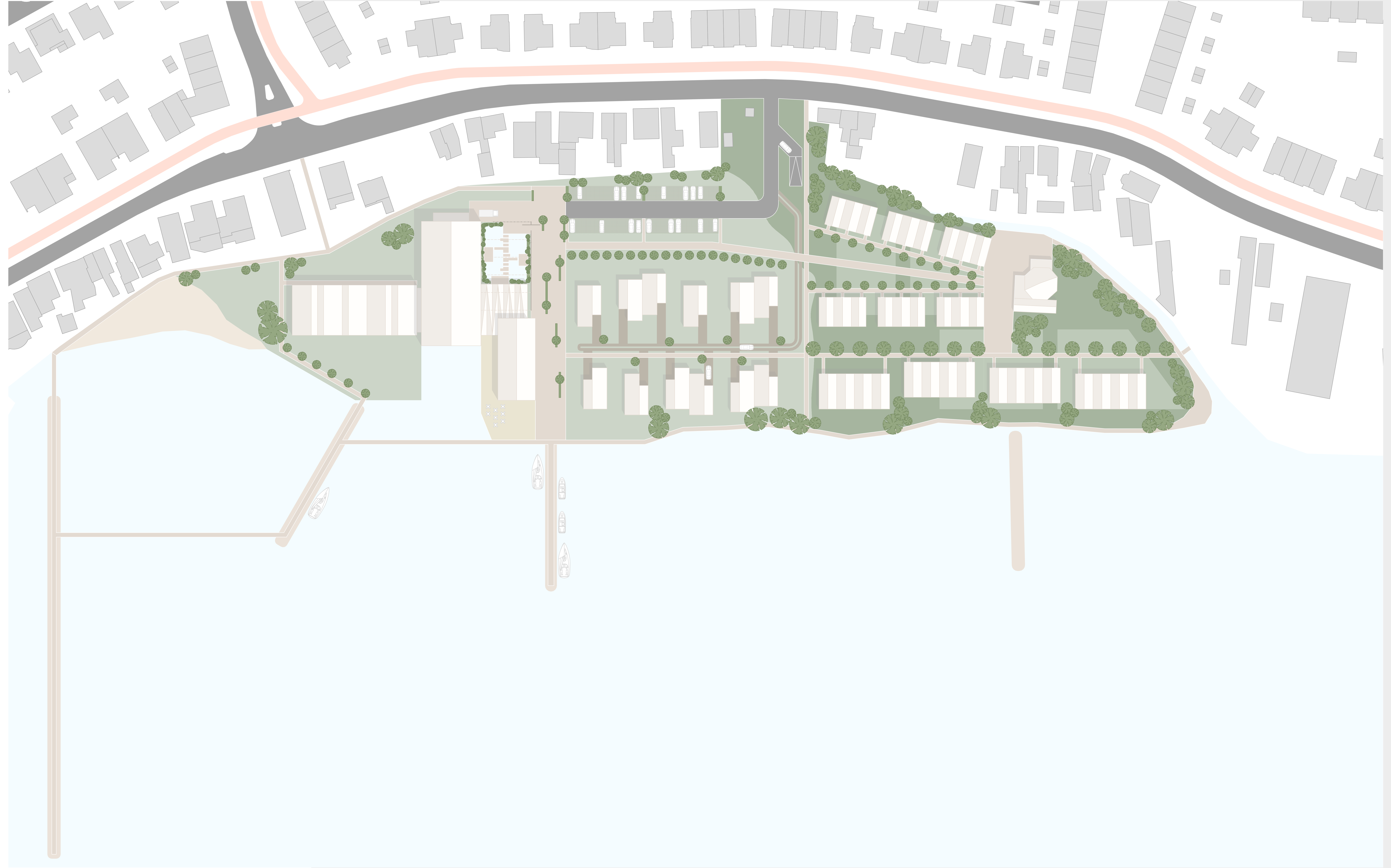

Master plan

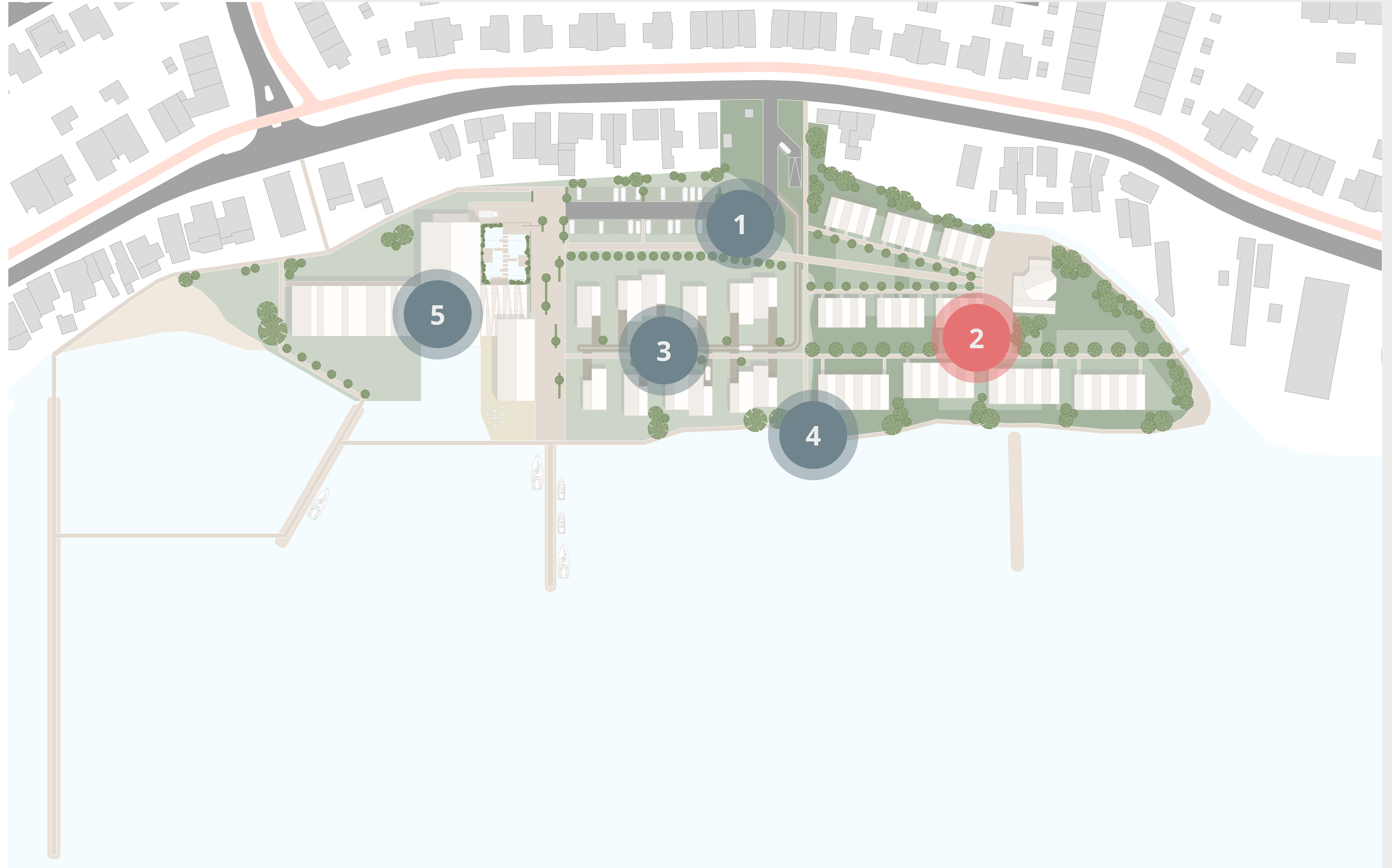

Master plan



Master plan

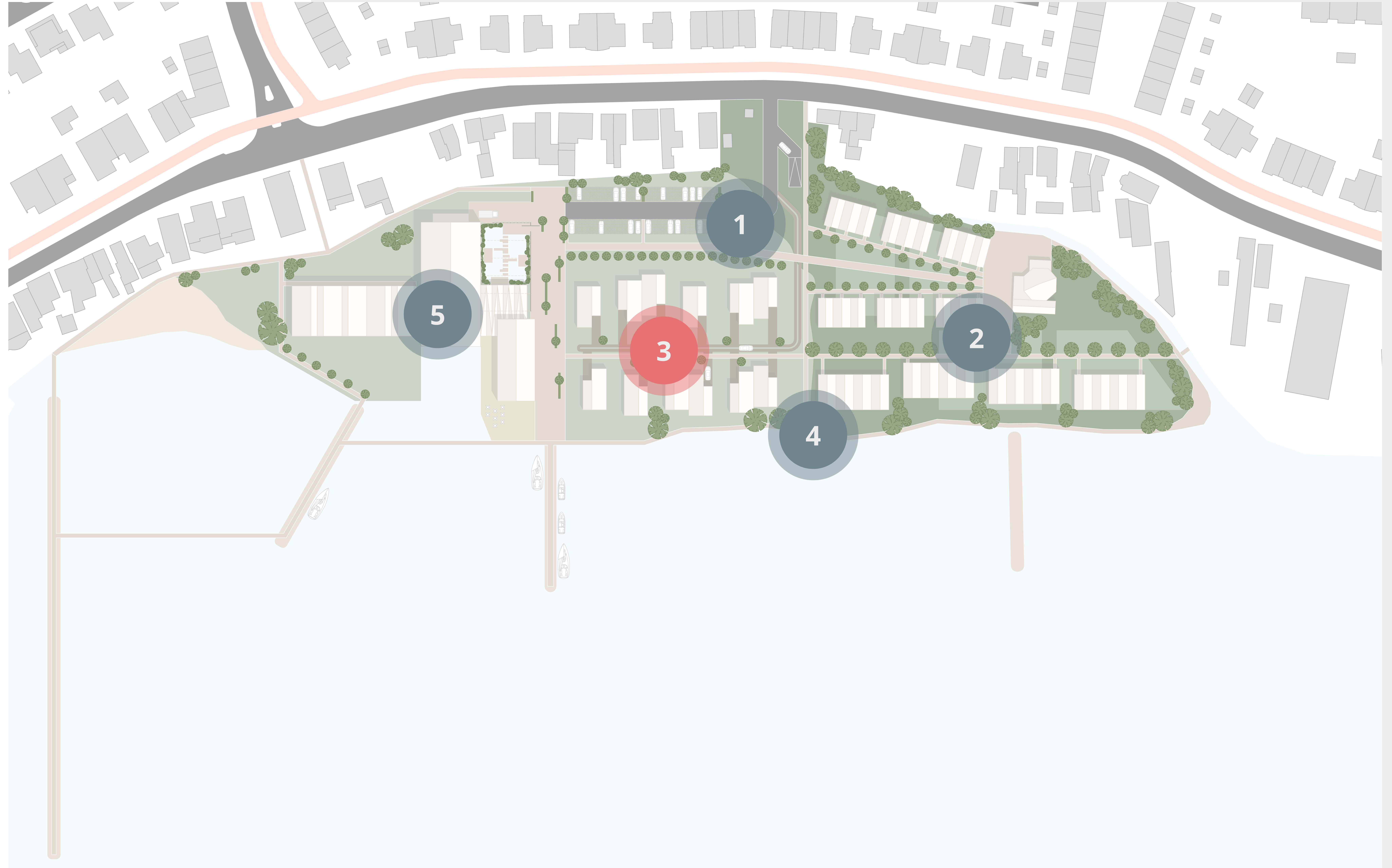

Master plan



Master plan

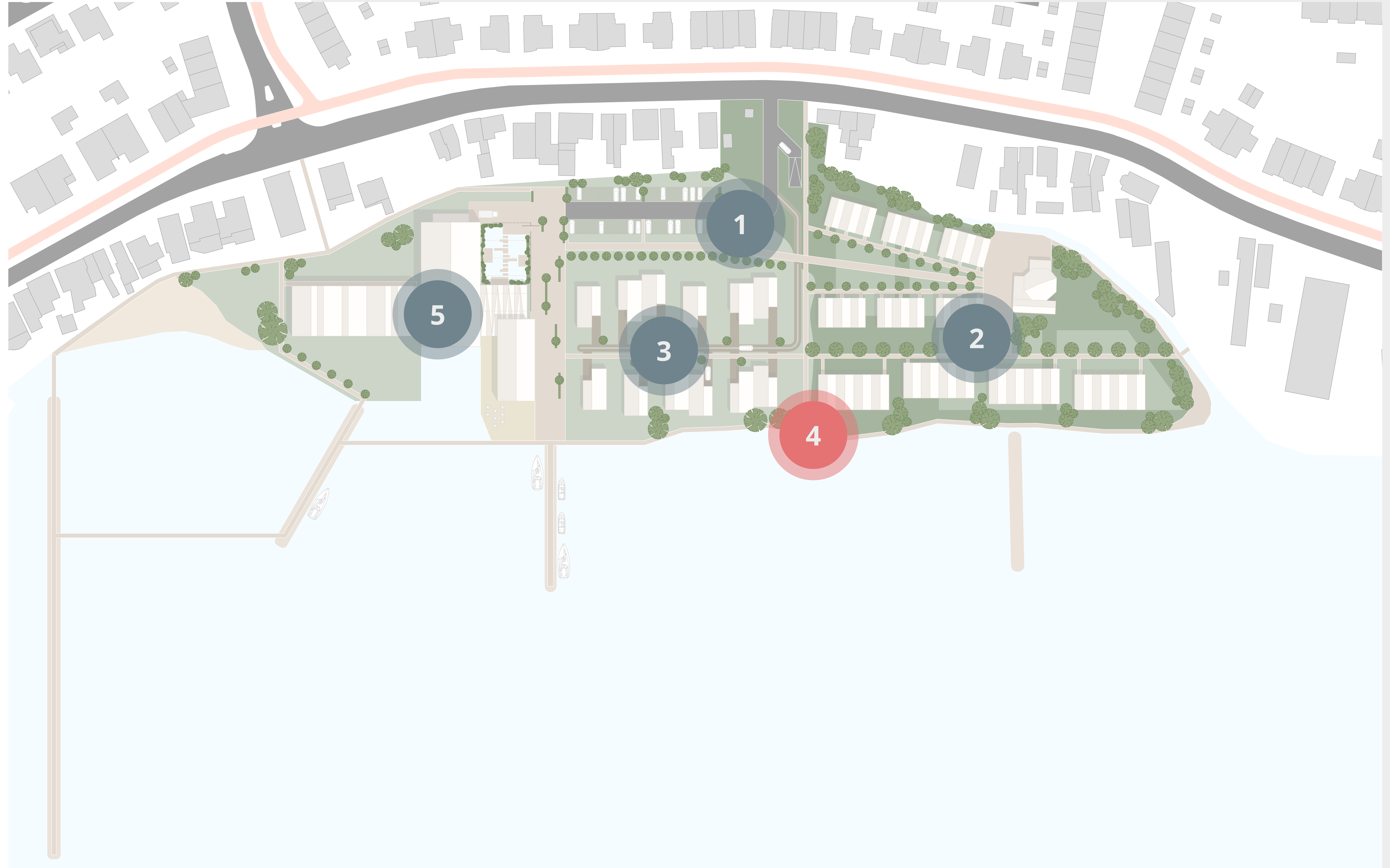

# Master plan

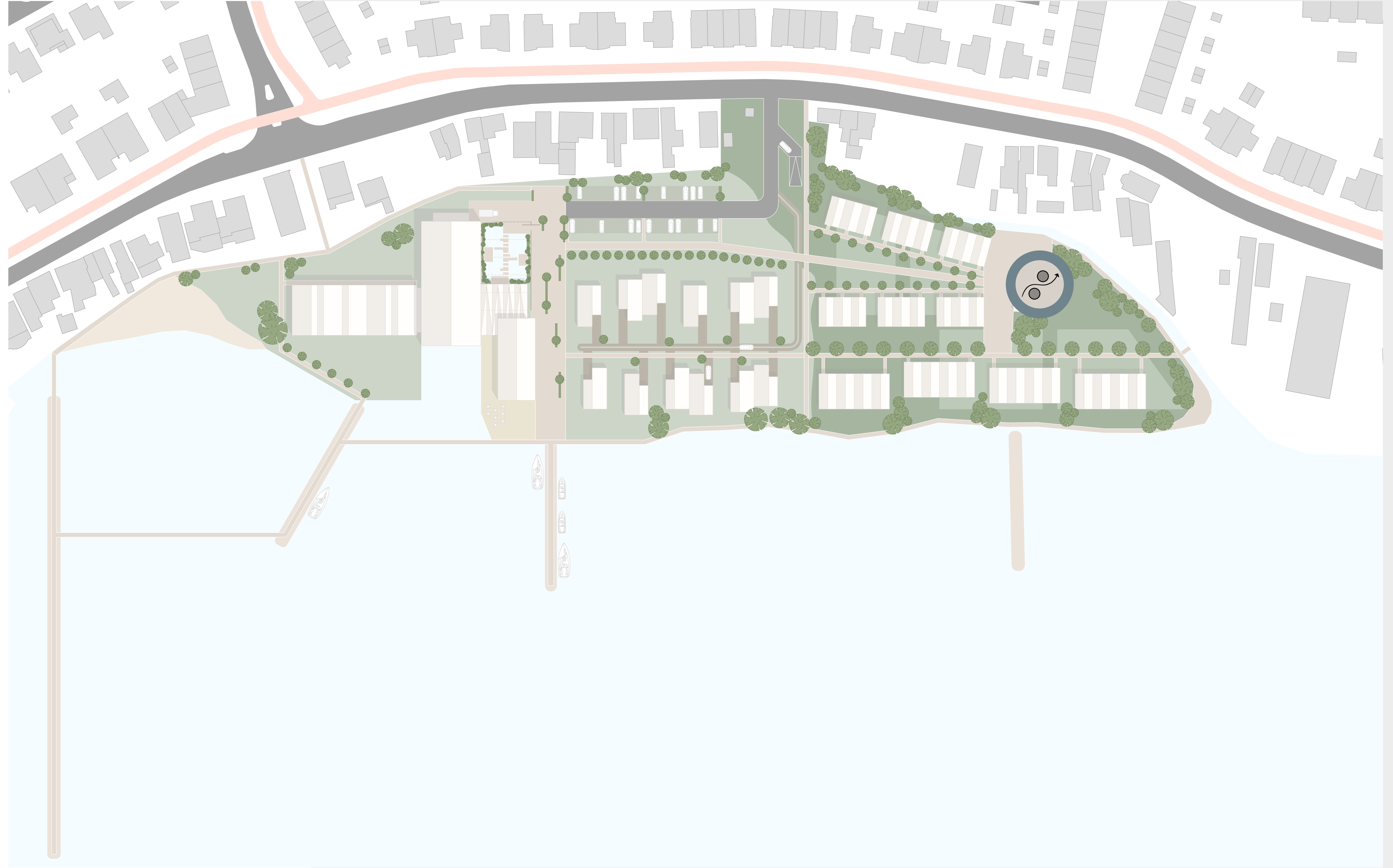

# Master plan

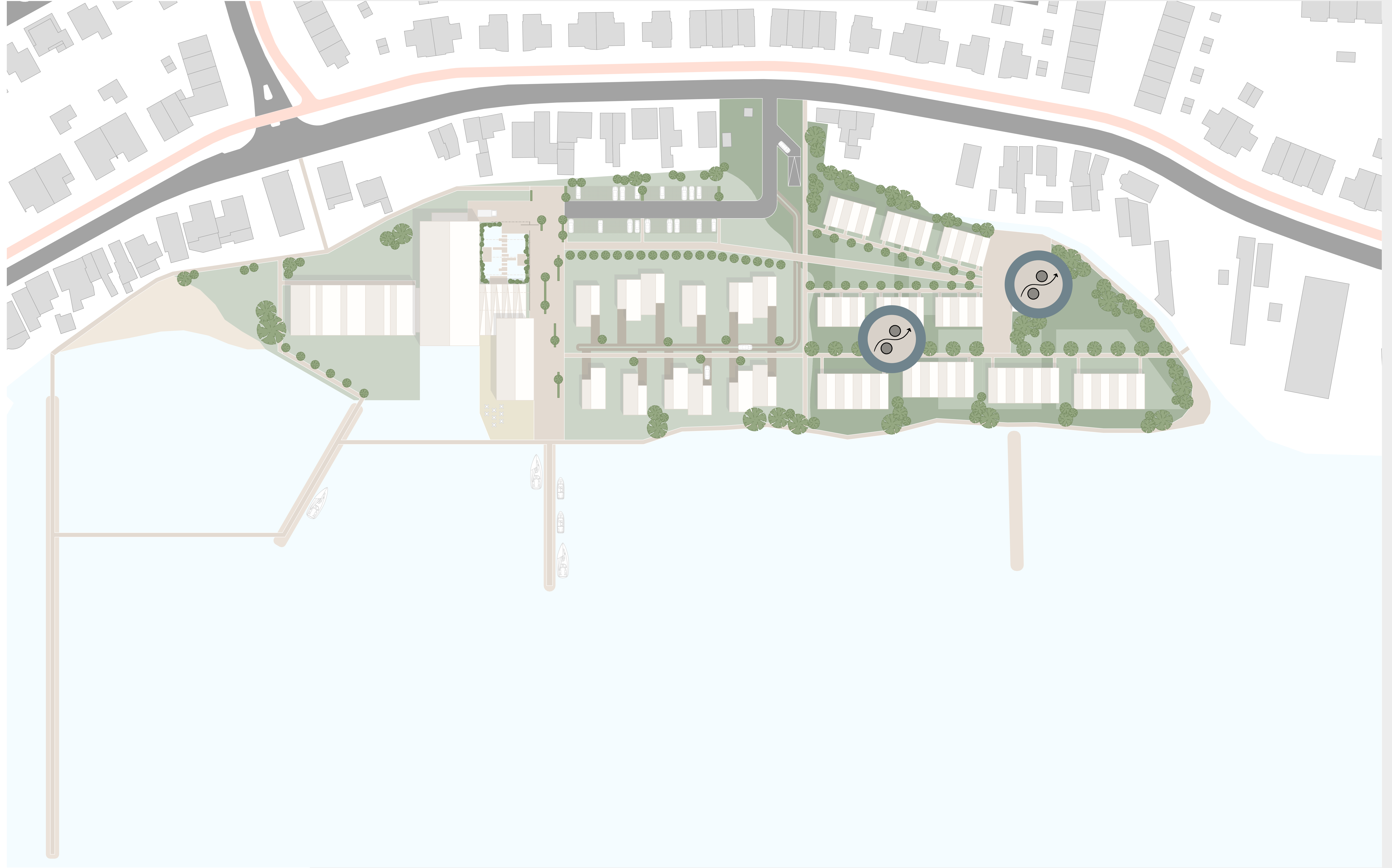

# Master plan

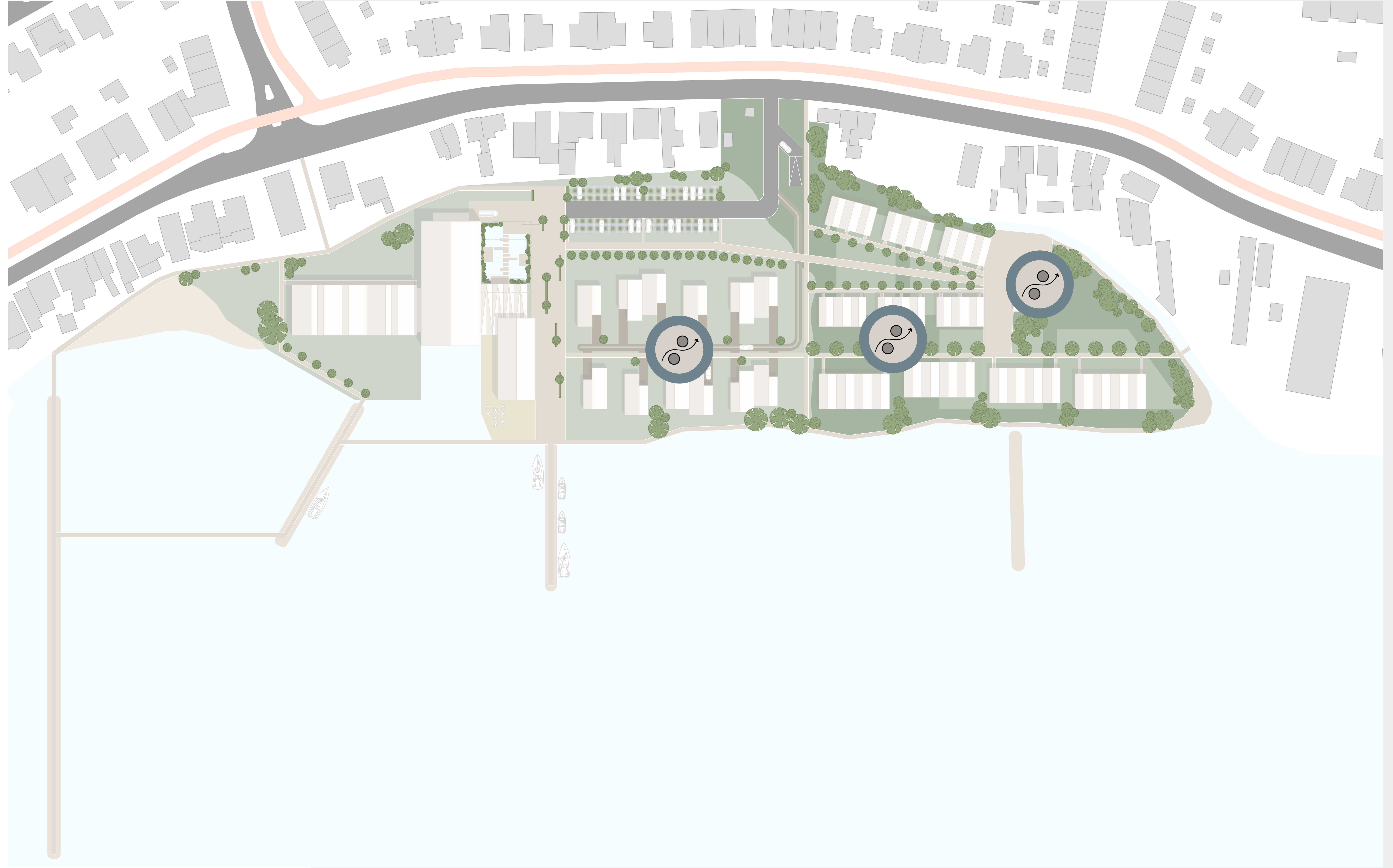

# Master plan

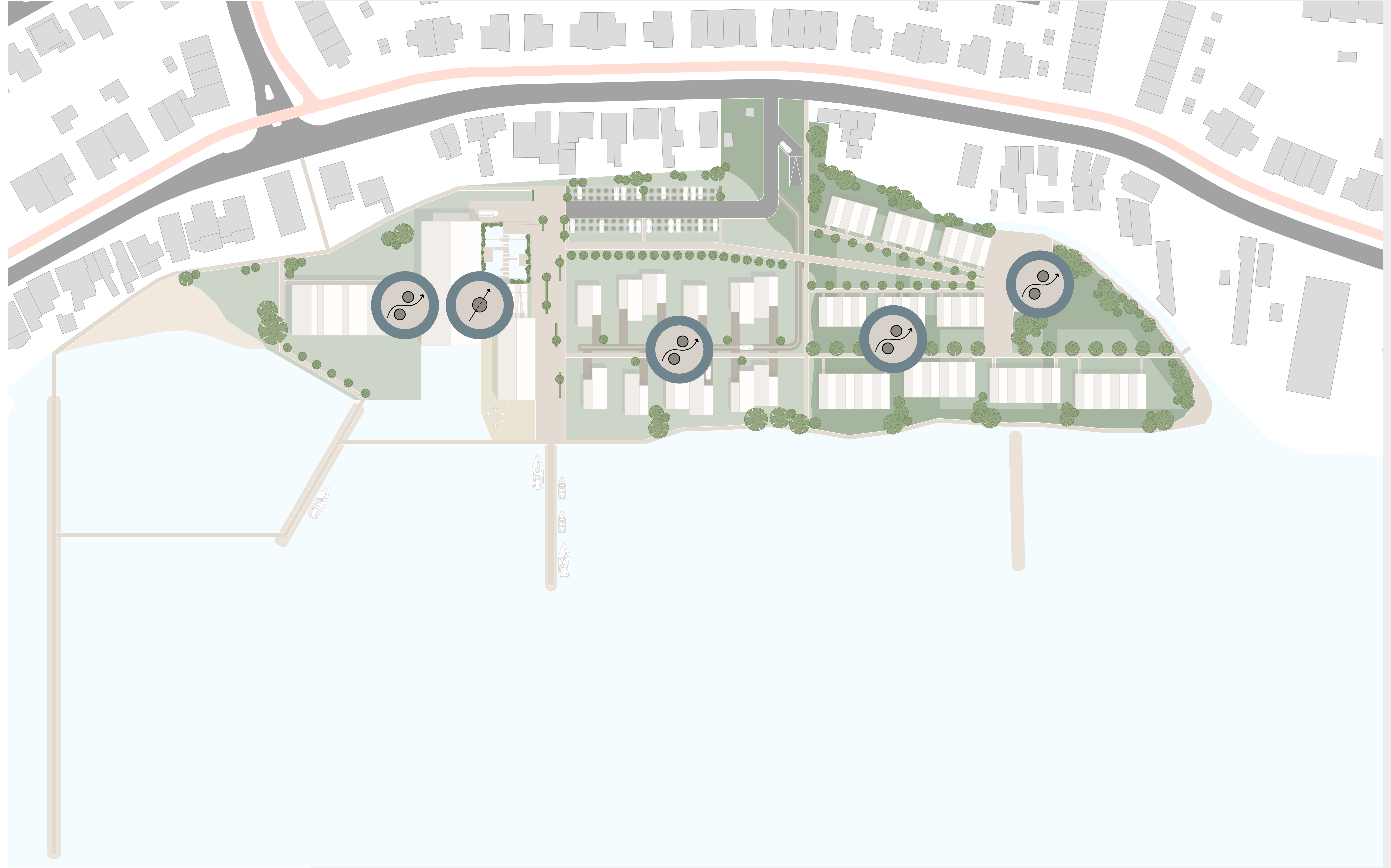

Master plan

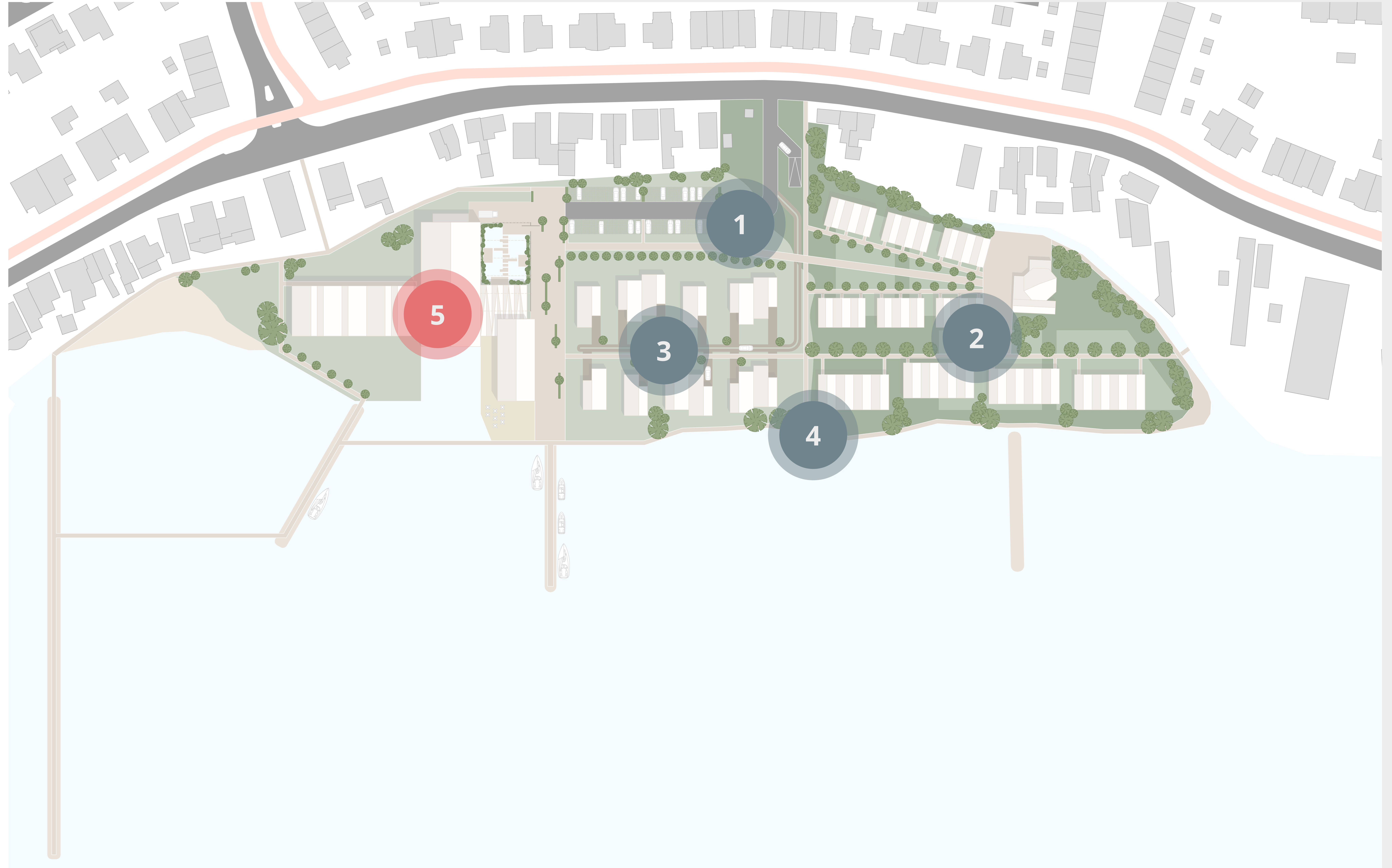

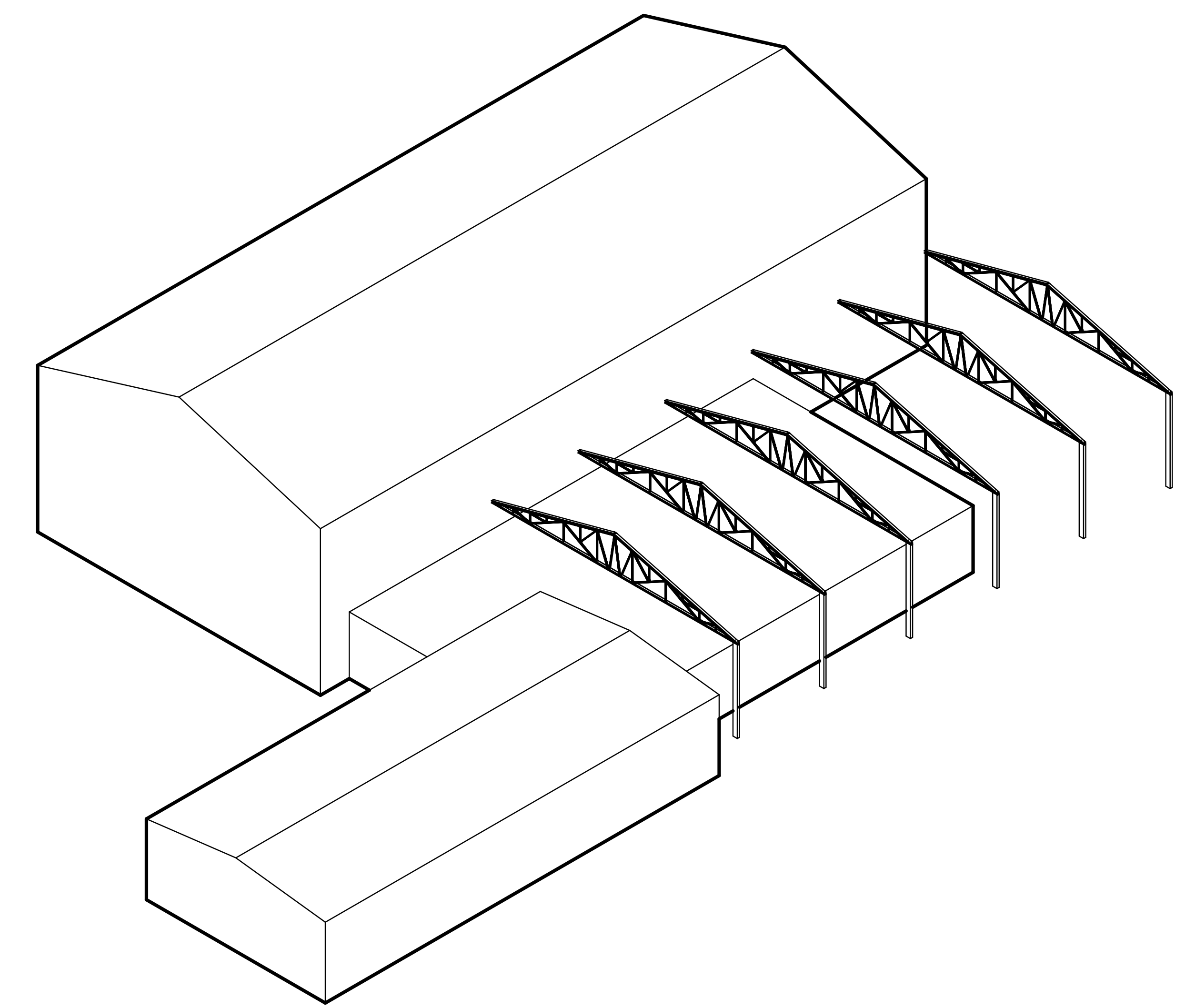
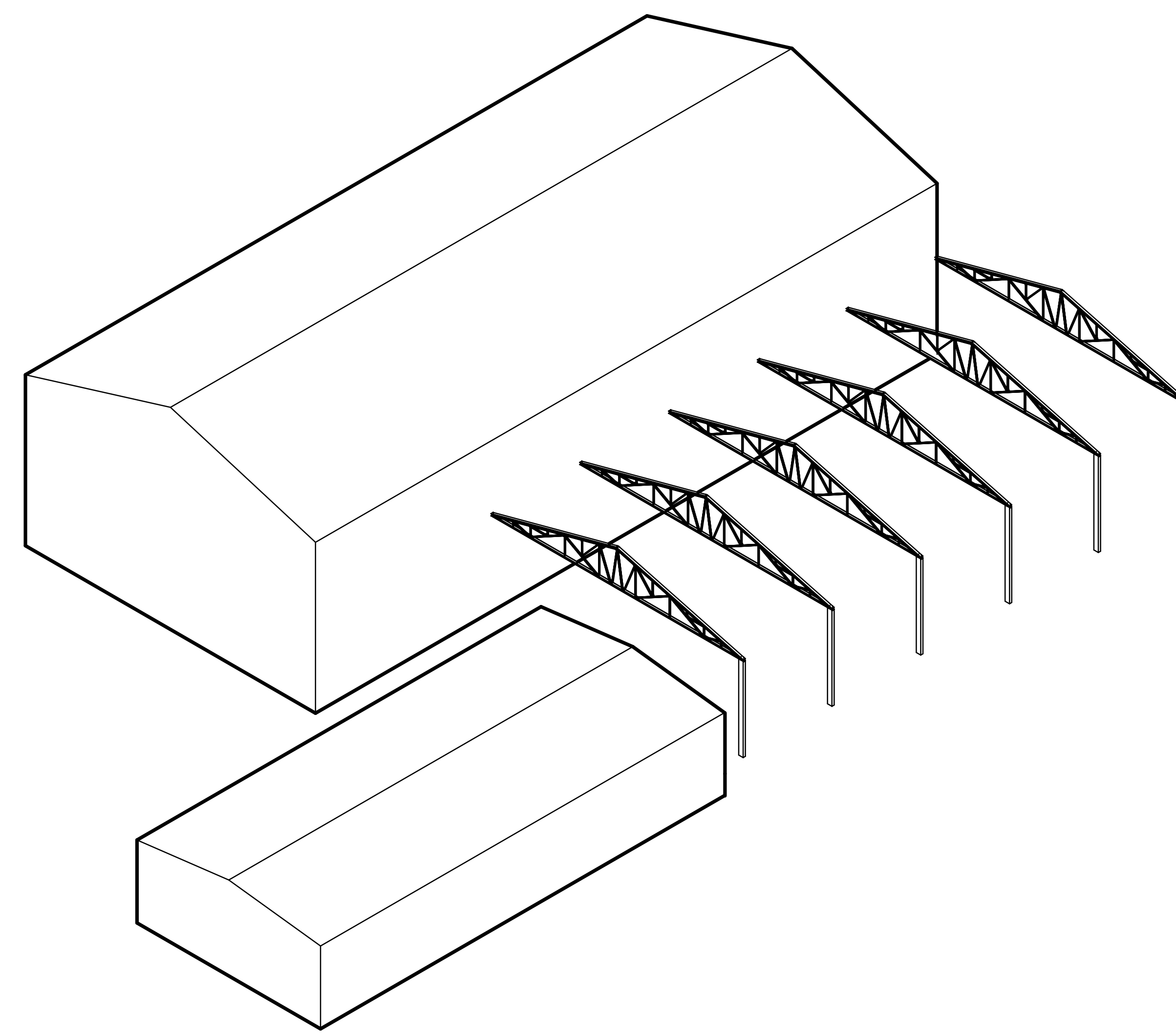
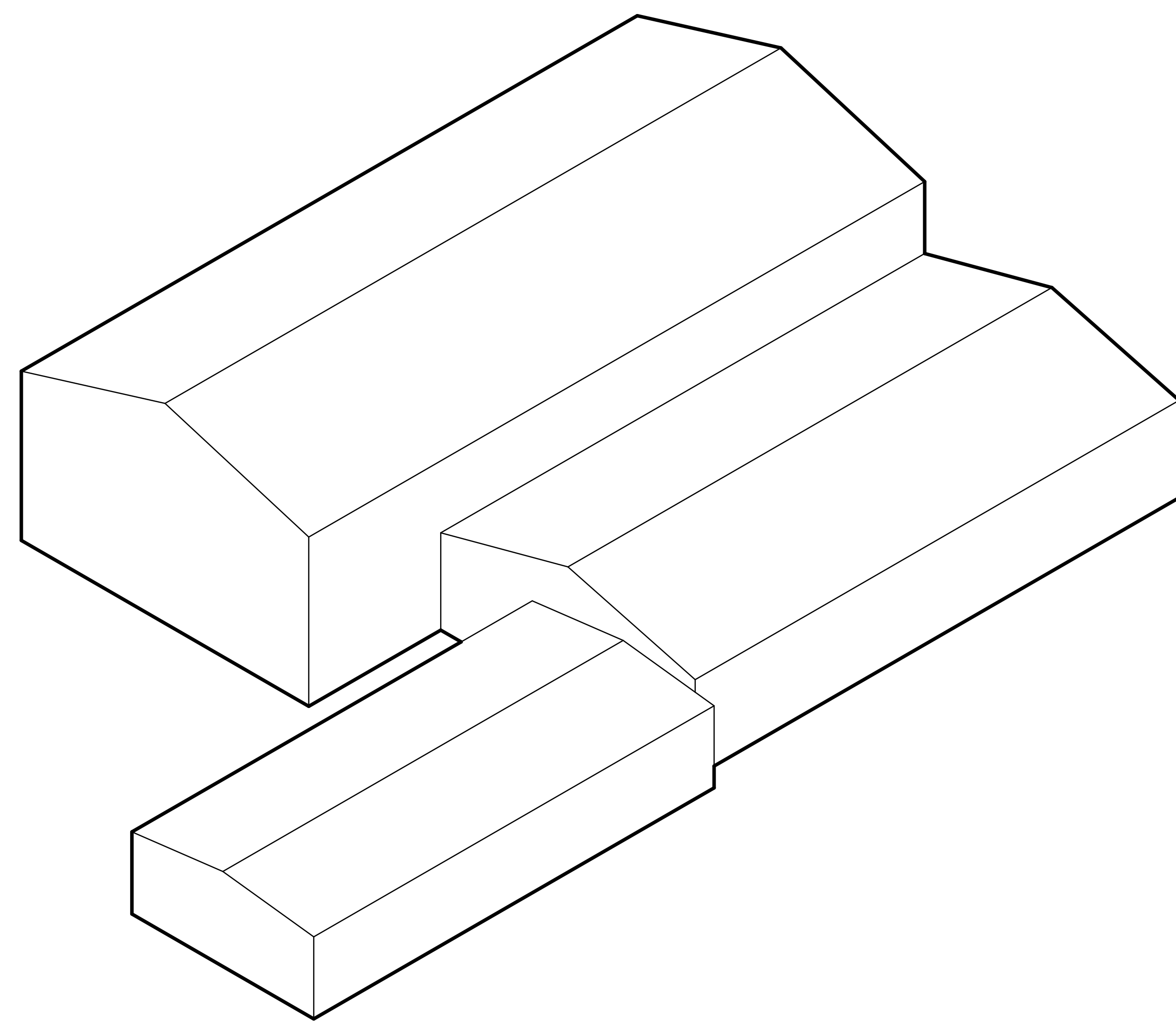



Lobby



Conference  
Center

Lobby

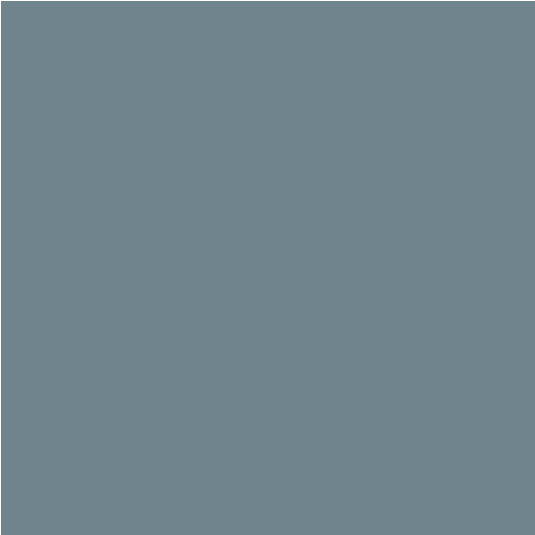
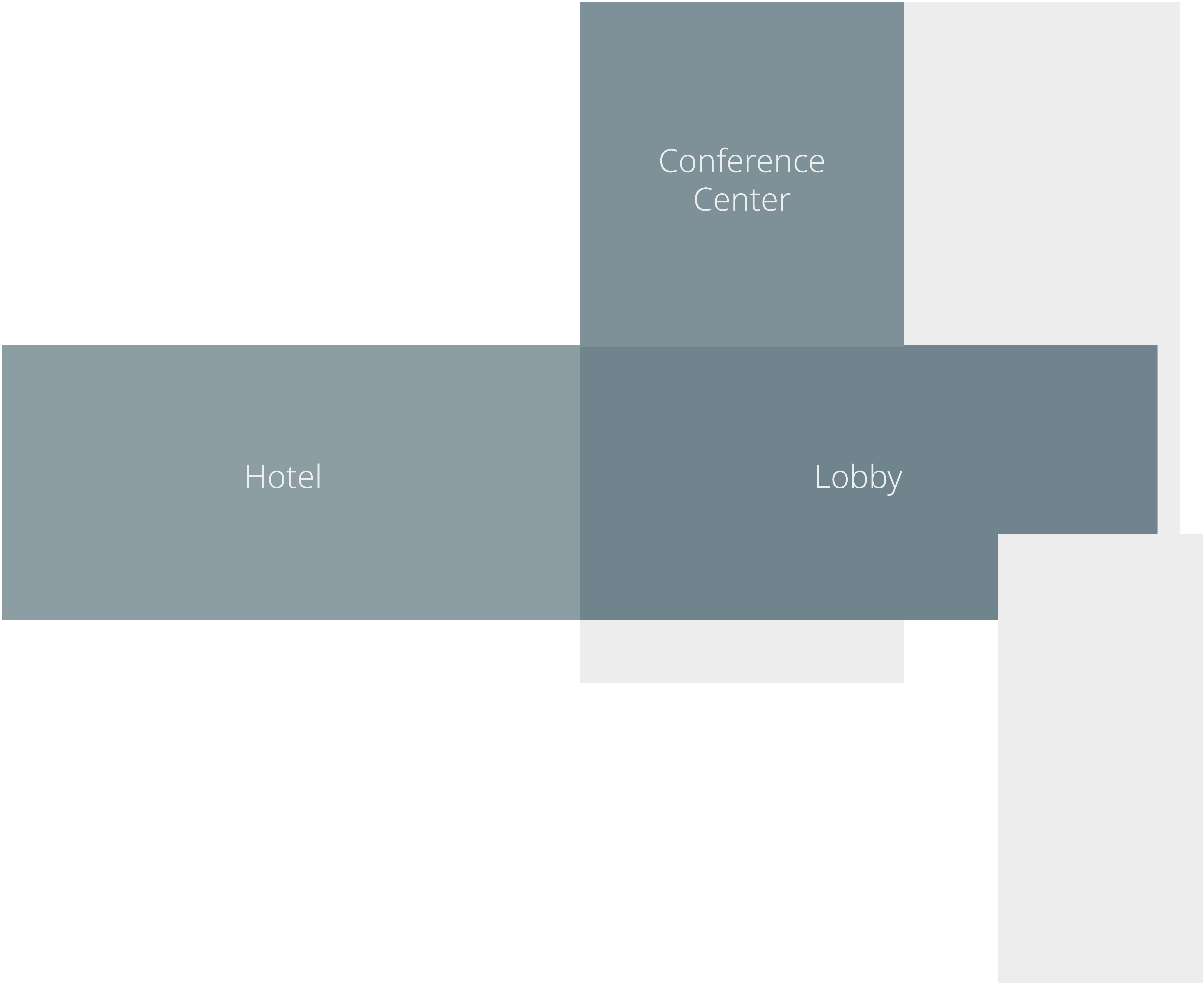

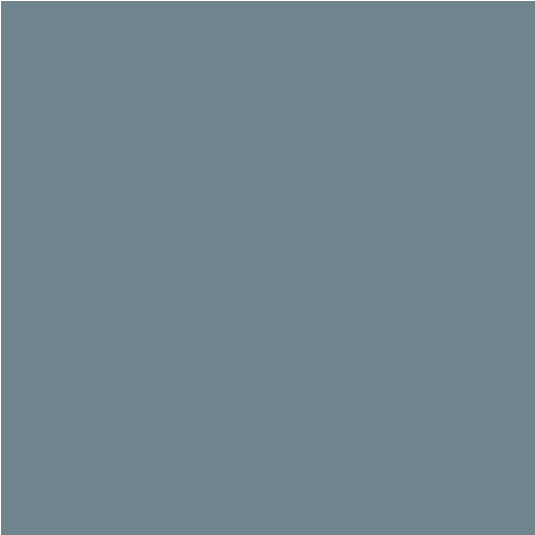
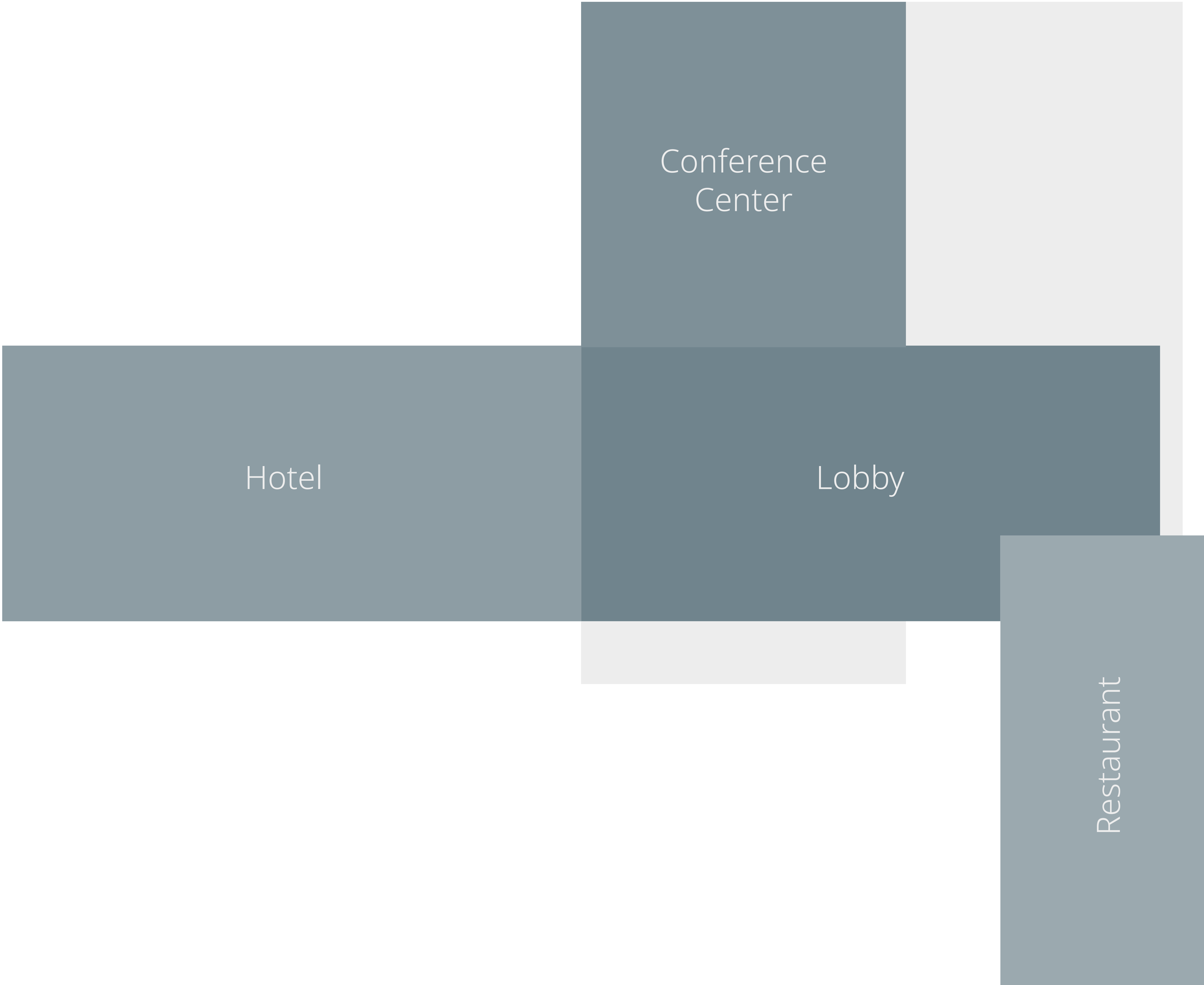





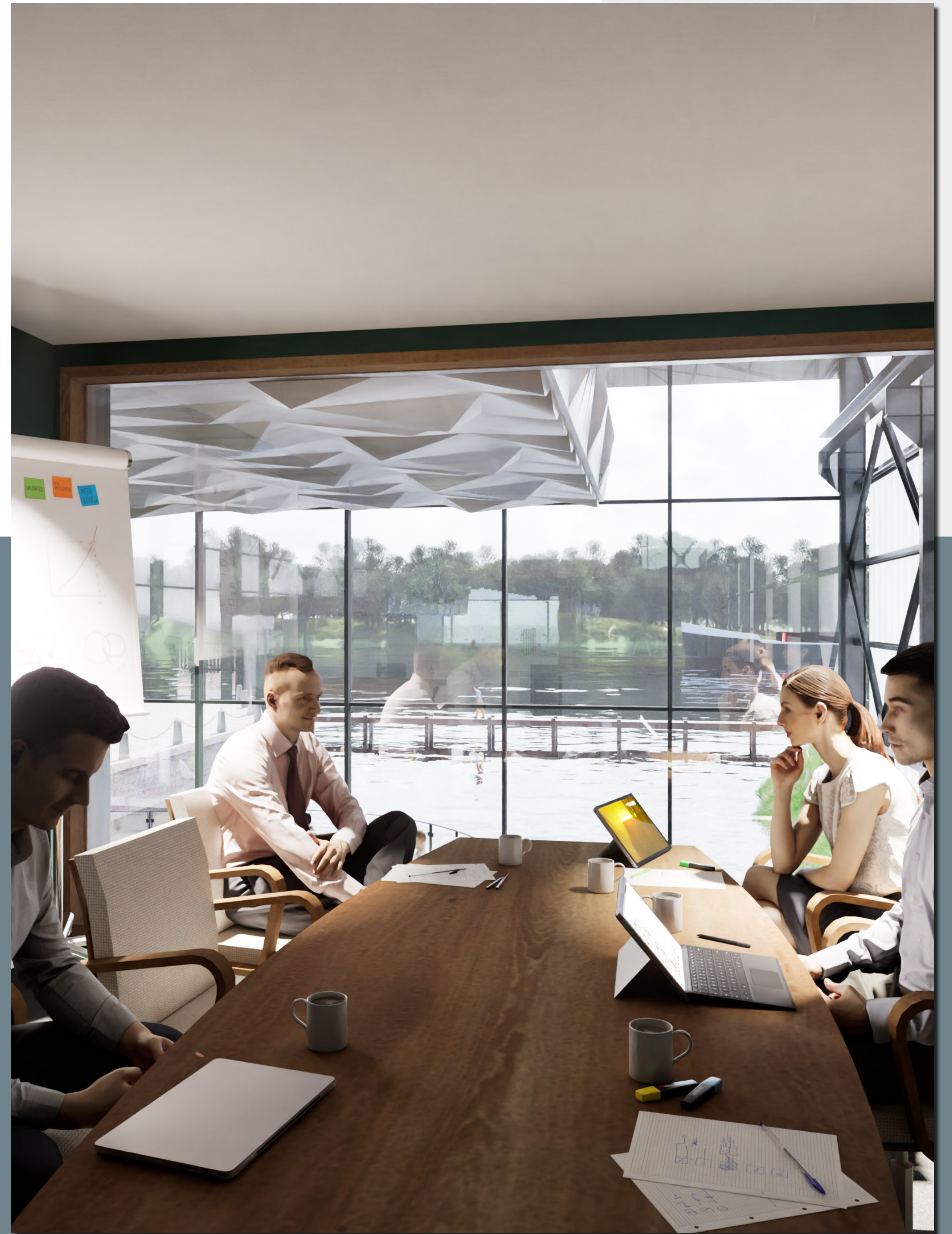

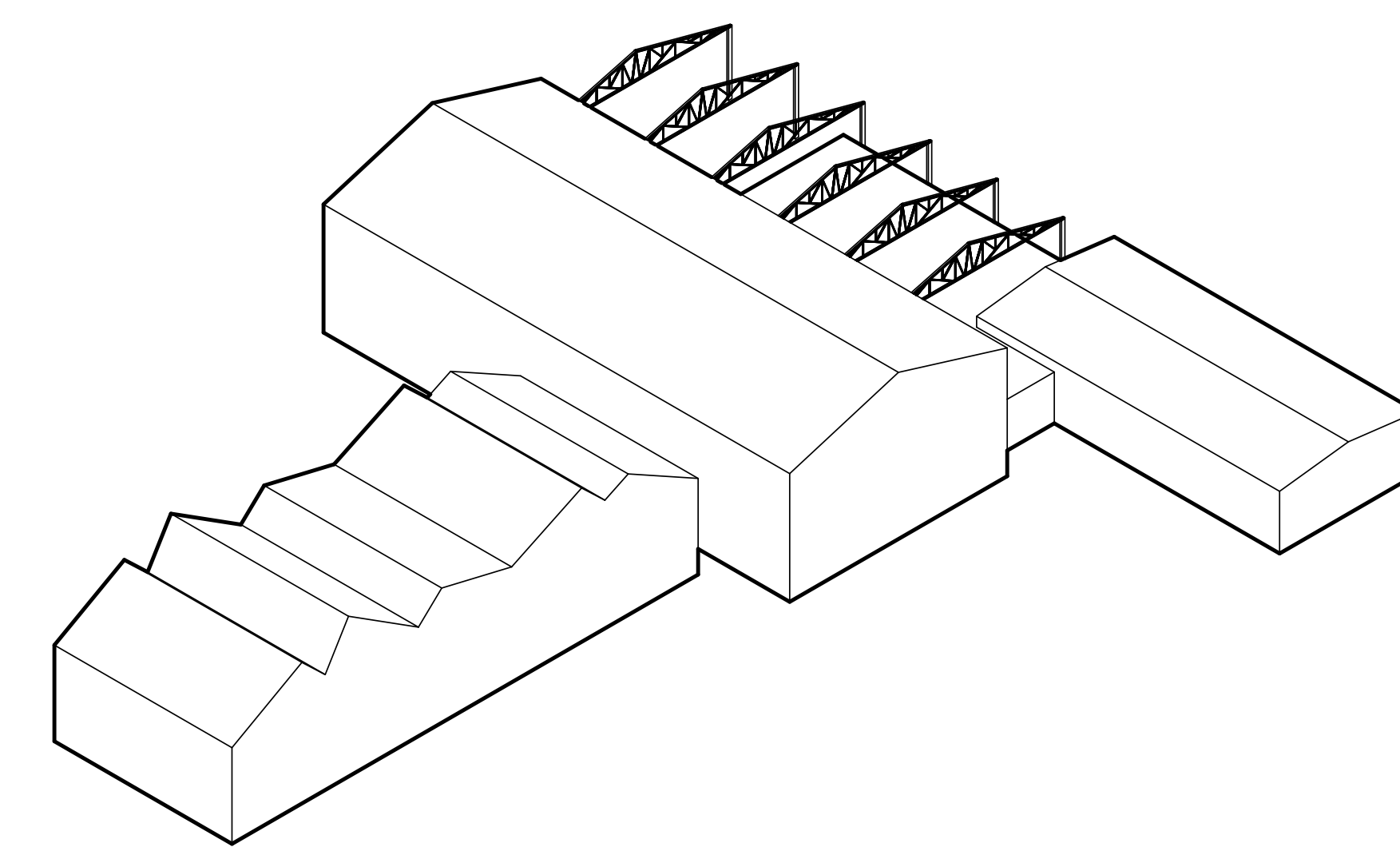
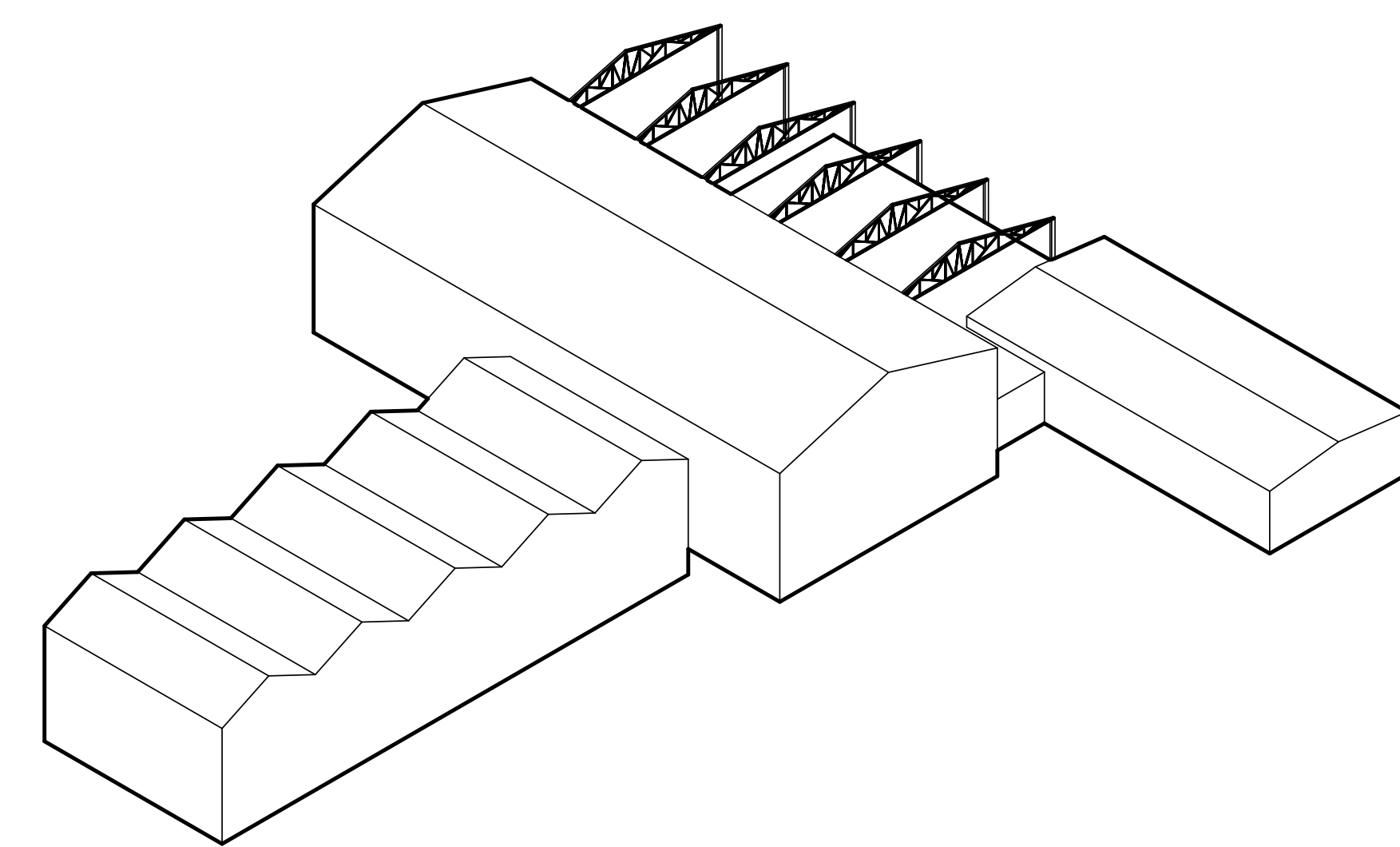
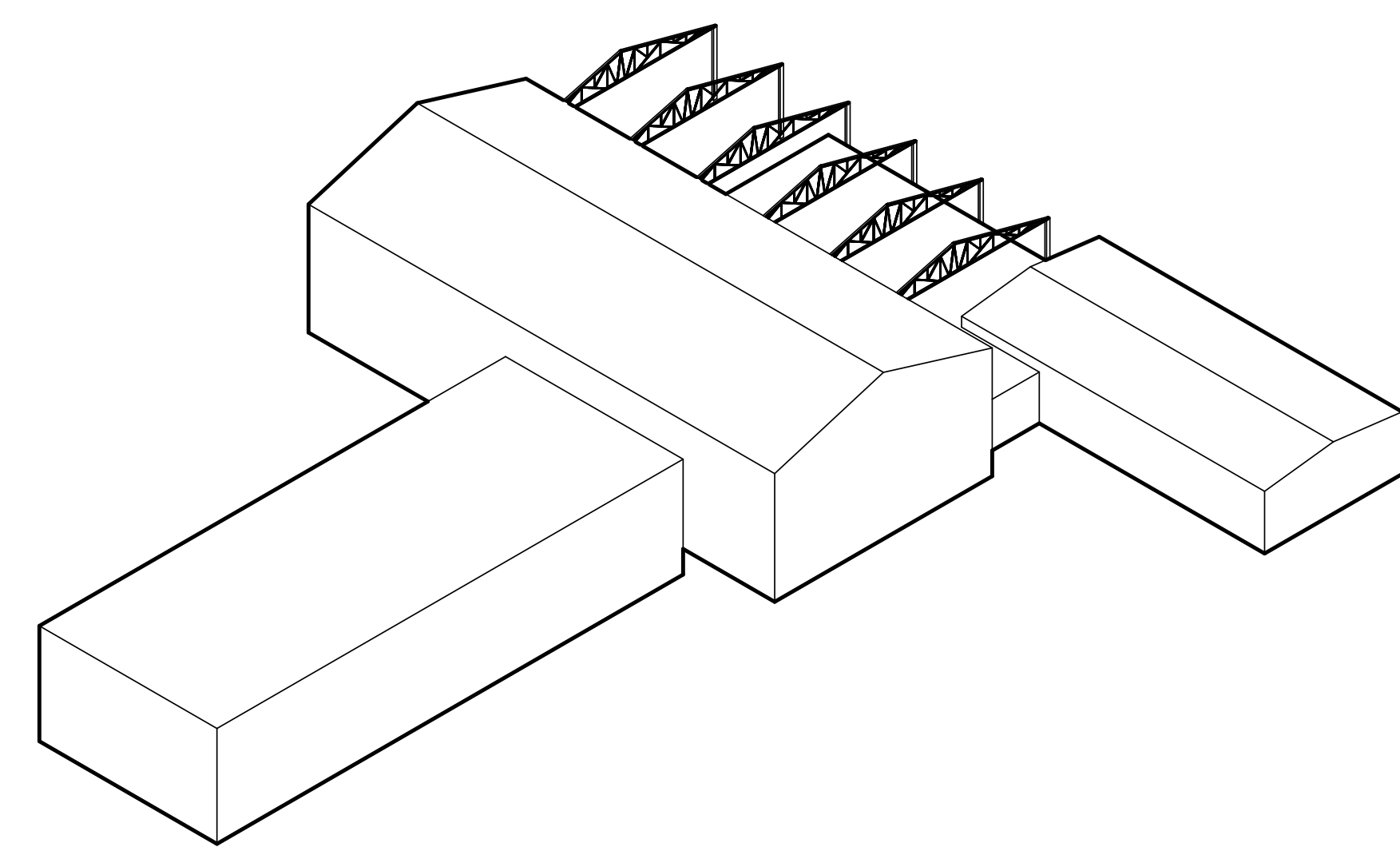
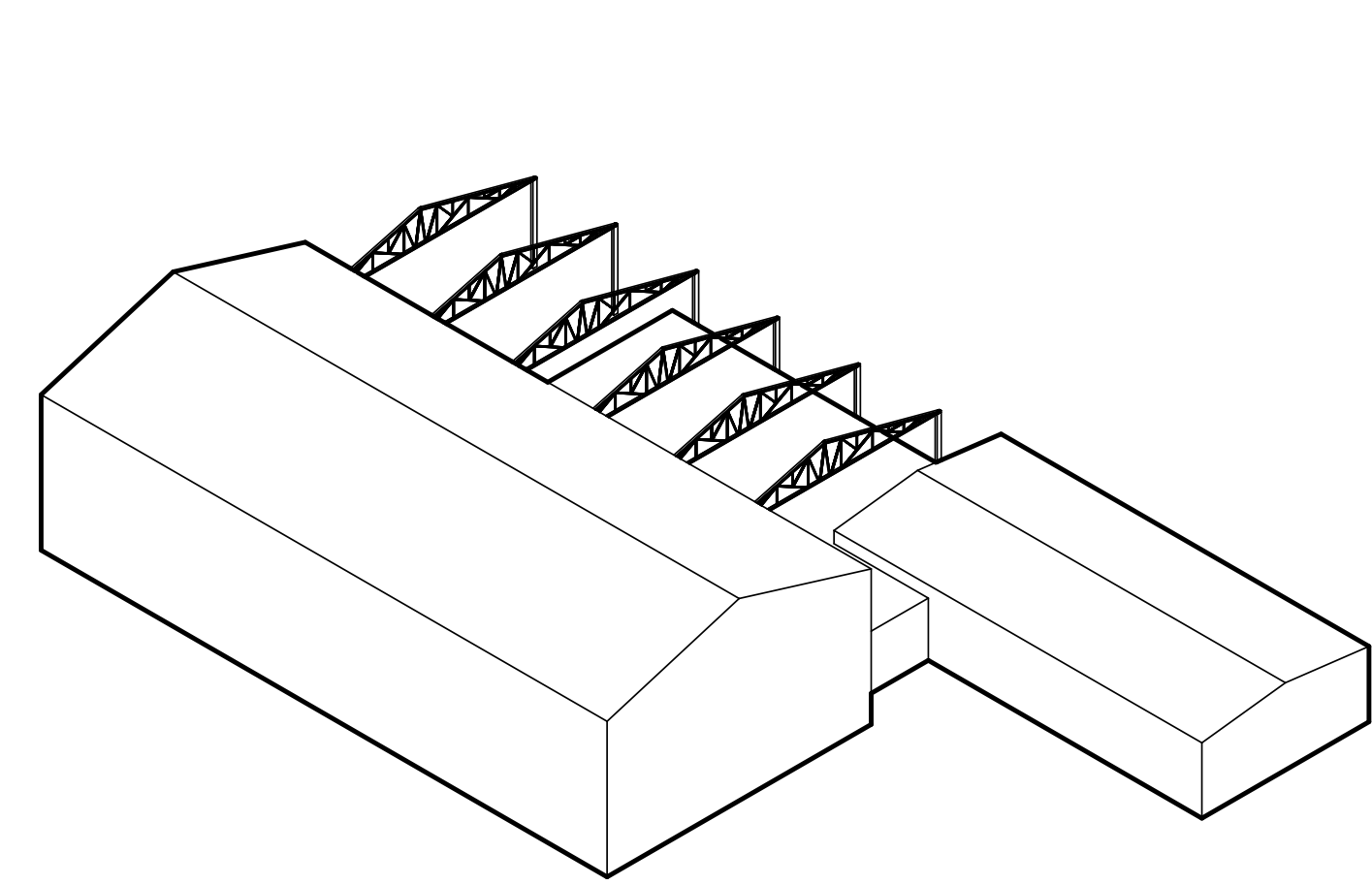

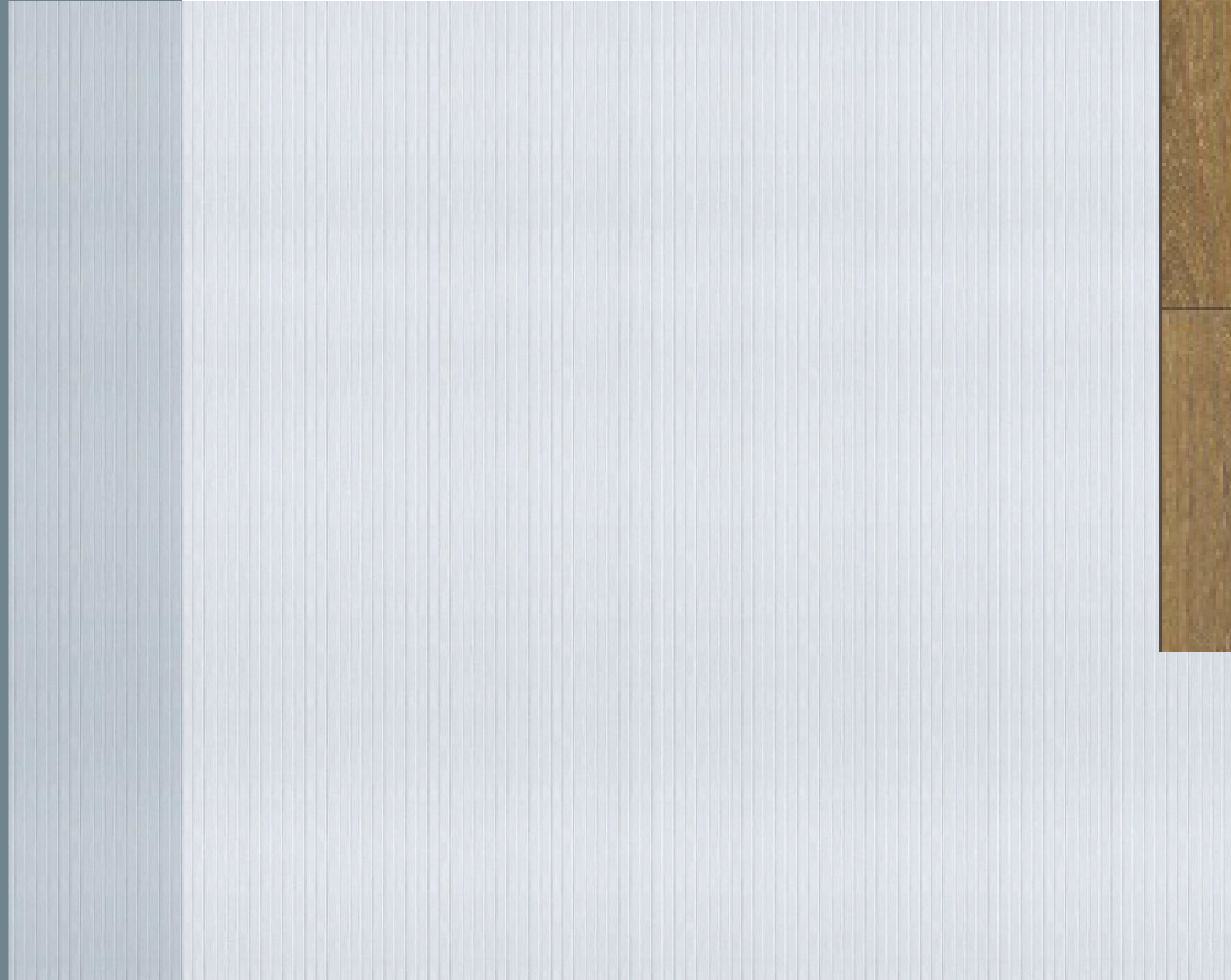

Polycarbonate



Timber



# Energy

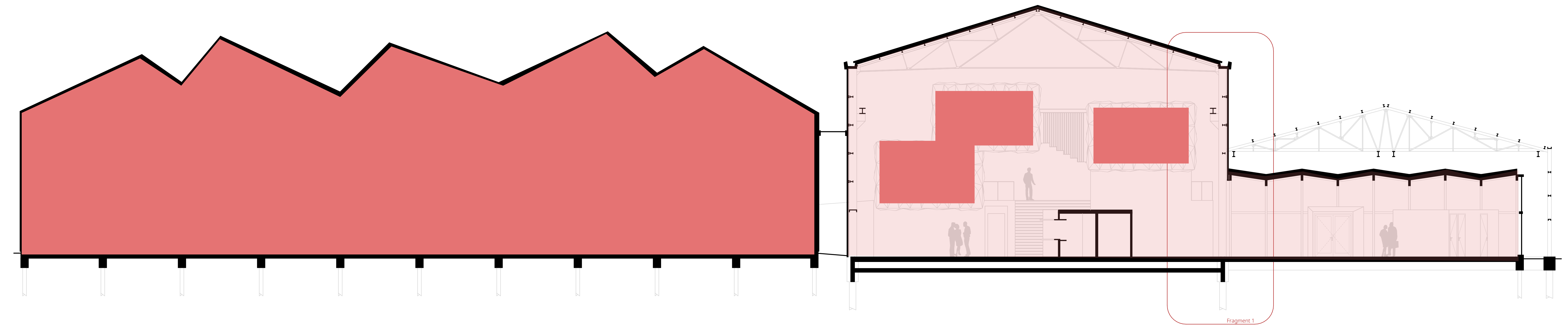

Section AA

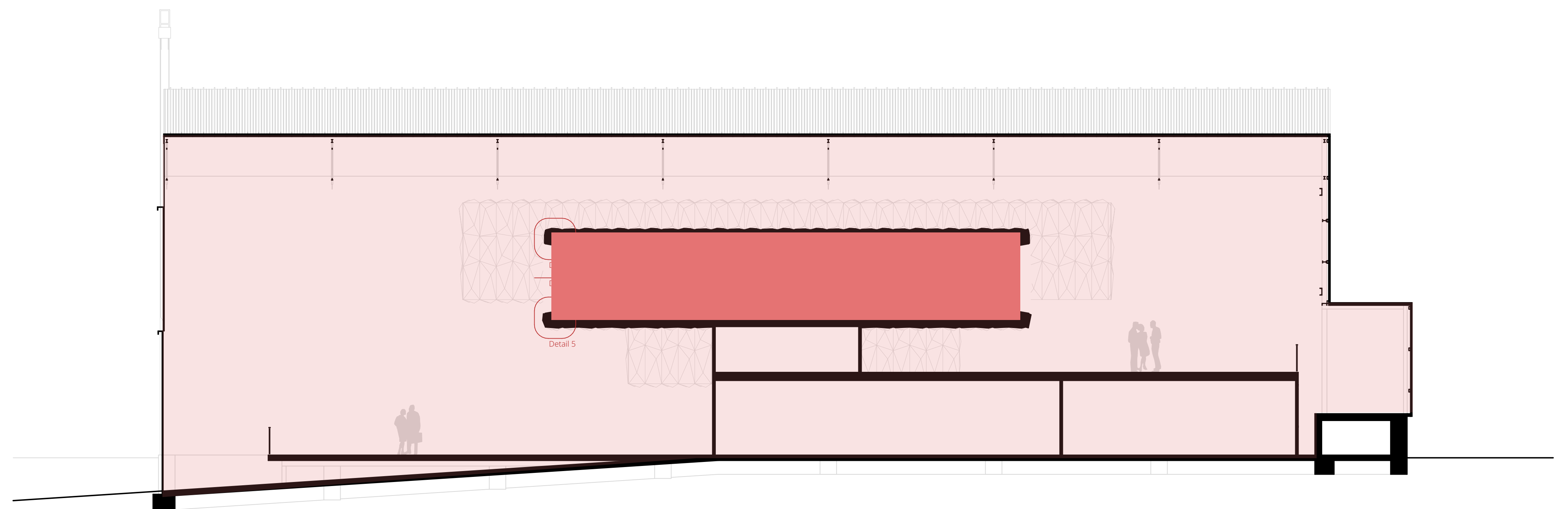

Section BB

