

Healing environments within existing hospital architecture

A study into architectural interventions in the AMC Amsterdam

P5 – Robotic Building – 03/11/20 – Leander Bakker – 4292103

Henriette Bier – Arwin Hidding – Ferry Adema

Overview

The Academic
Medical Center

The relation
between
healthcare and
design

The Future Of
Healthcare

The Design



amc

Universiteit van Amsterdam

The Academic Medical Center

The complex where healthcare, research and education meet as a city

Introduction to the AMC



The AMC Vision

Hallo. Wij zijn
Amsterdam UMC.



Social responsibility



People in the AMC



Planet in the AMC

samen beter

The problem statement



The research question

How to create an architectural intervention that functions as a healing environment within the existing structure of the AMC?

The AMC city



The AMC city



The Grid

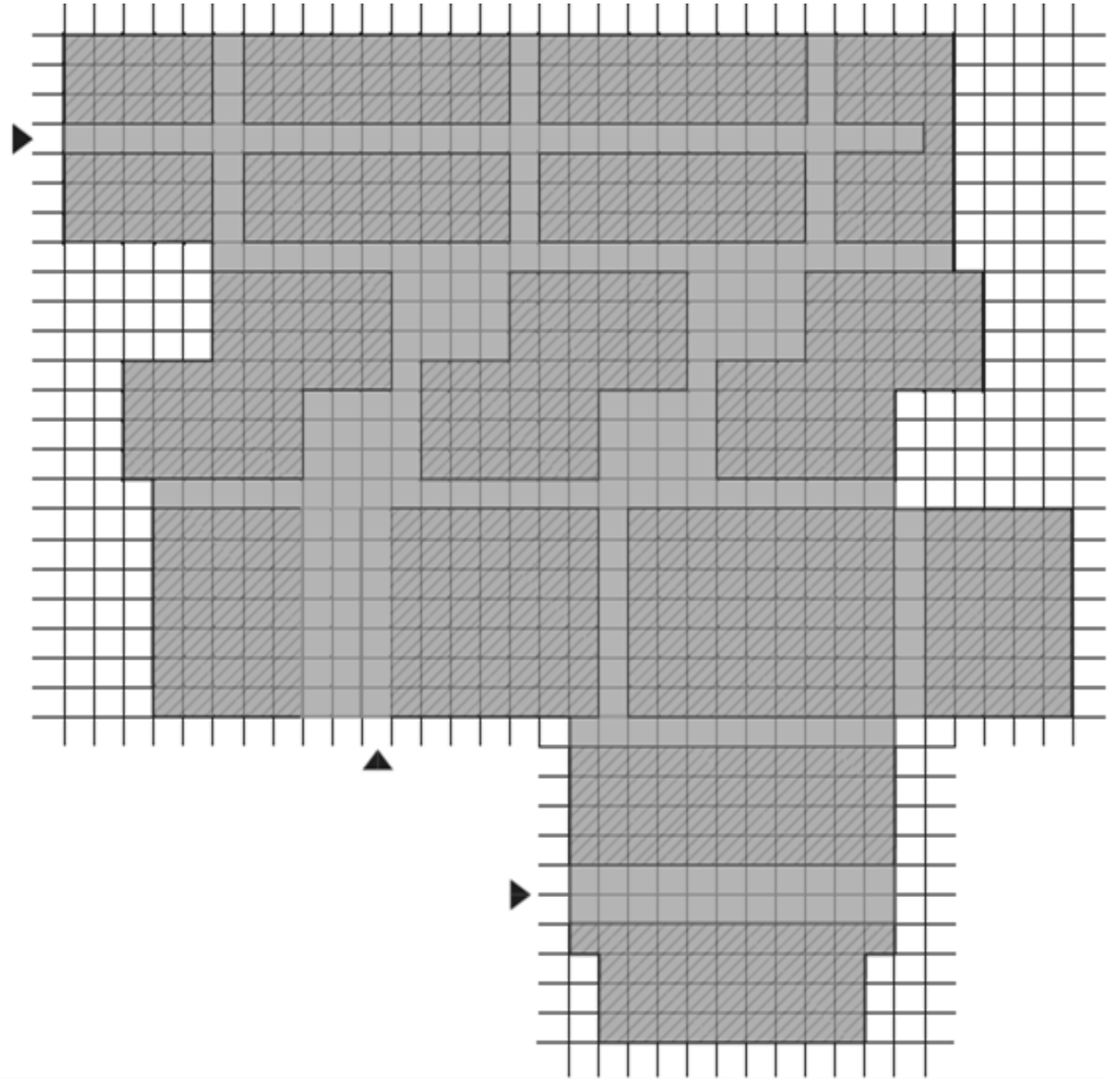

The structure

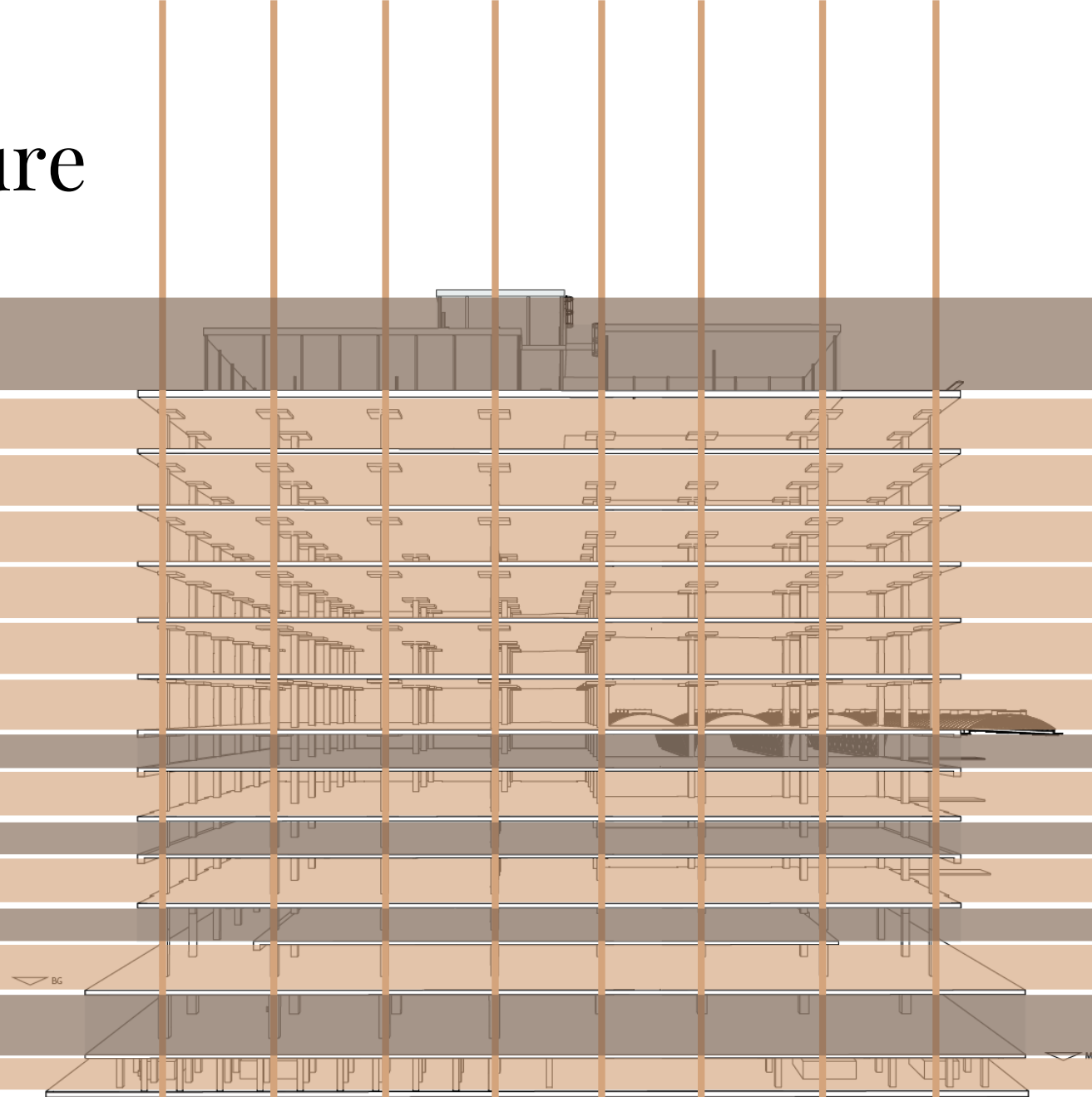

Development Constrains



24/7 operational



AMC Borders



Concrete appearance

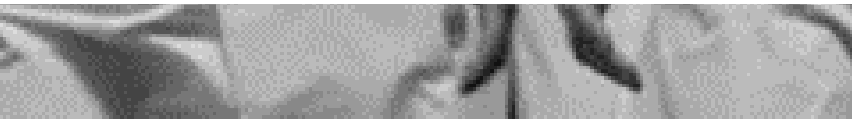



am

The relation between healthcare and design

Creating healthy environments

The users

A black and white photograph showing a medical professional, likely a doctor or nurse, in a white coat with a stethoscope around her neck, smiling and talking to an elderly male patient lying in a hospital bed. A woman, presumably a visitor, stands by the bedside, looking towards the patient. The setting is a hospital room with a computer monitor on a stand in the background and a window on the right.

Visitors

Patients

Employees

Hospital experience



Characteristics for patient wellbeing



Safety and Security

Spatial comfort

Privacy

Autonomy

Sensory Comfort

Social comfort

Daylight



Nature



Sight



Exercise





The Future of Healthcare

Research related to the future of healthcare and hospital design

Smaller hospitals



Faster treatment, diagnostics and workups



Effective disease prevention



Less invasive surgeries



Telemedicine



Better diagnostics at primary care centers



Specialized hospitals

Patient friendly hospitals



Large admission and reception areas



An increase in shopping facilities



An increase in restaurant facilities



Landscape gardens



Patient central in care and decision making

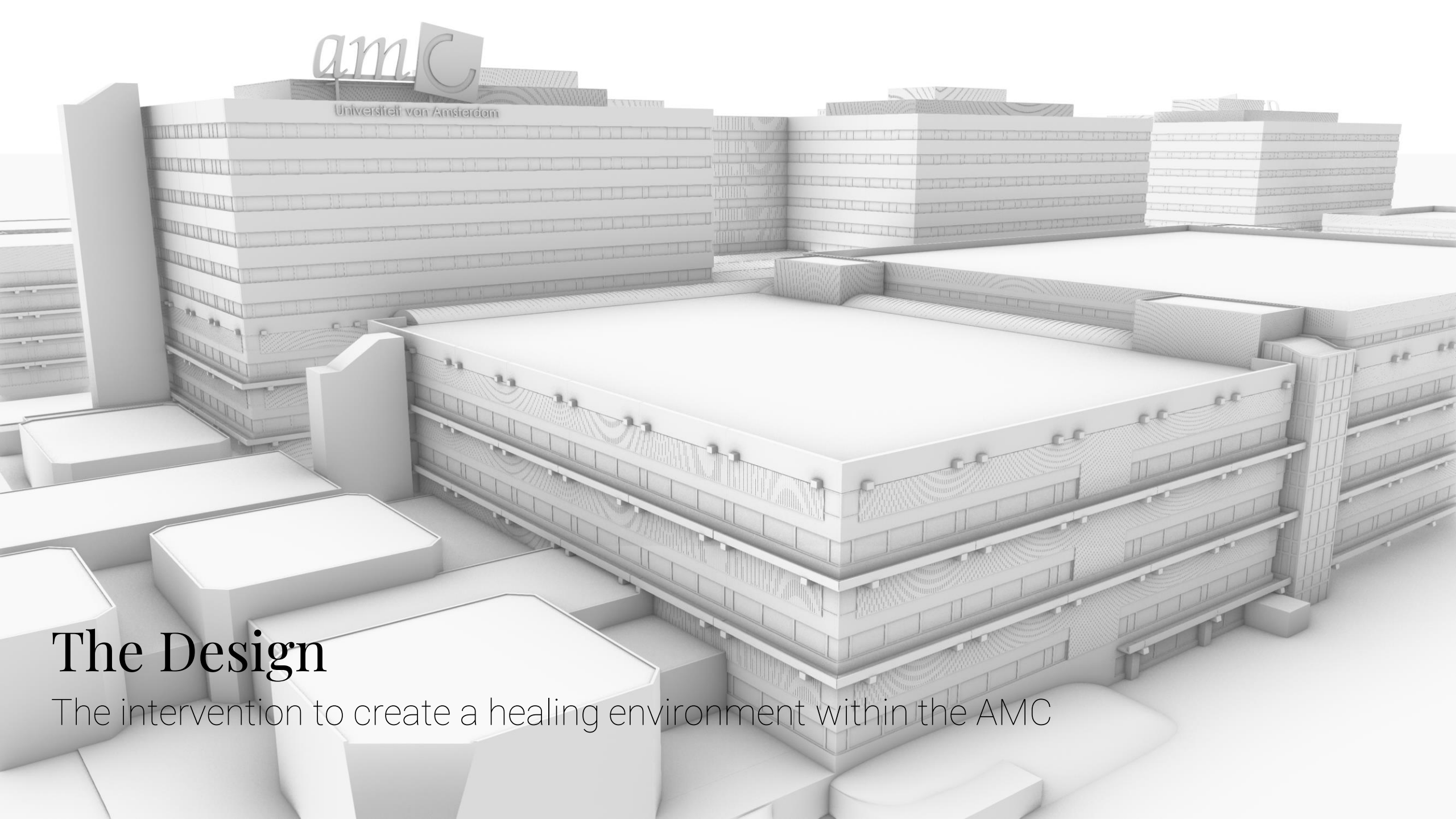

amc

Universiteit van Amsterdam

The Design

The intervention to create a healing environment within the AMC

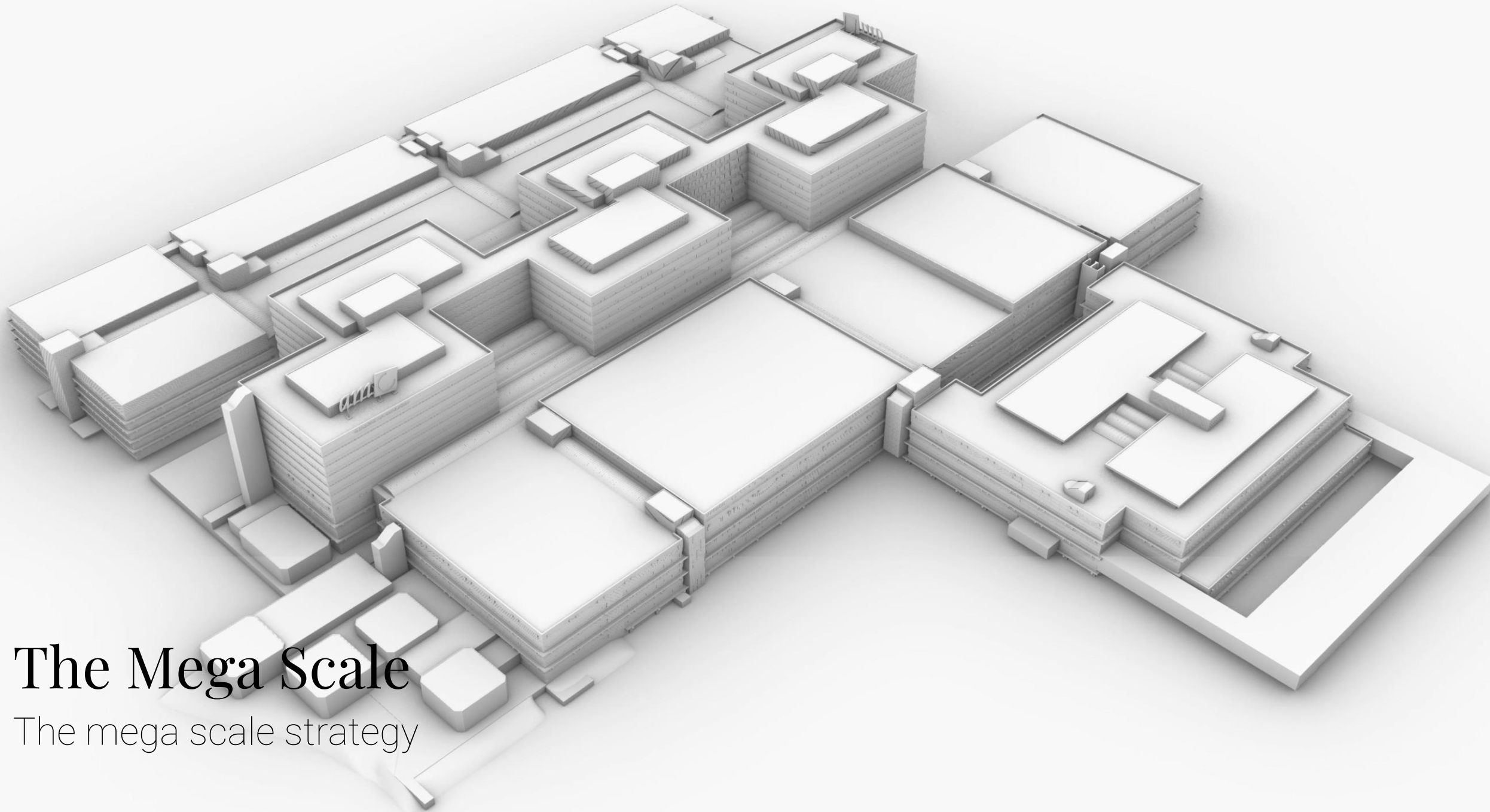

The Mega Scale

The mega scale strategy

Vertical expansion

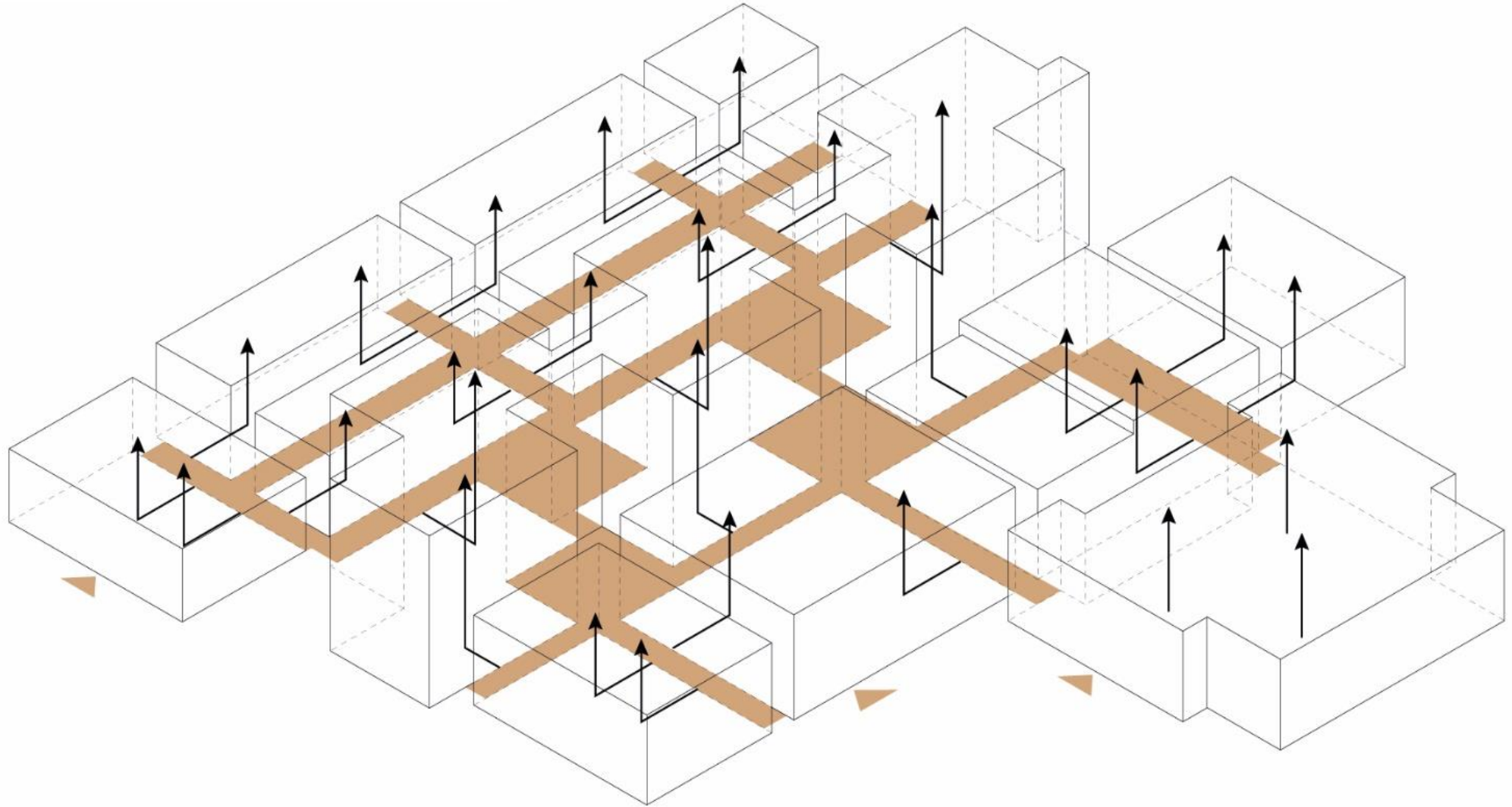

Pull functions

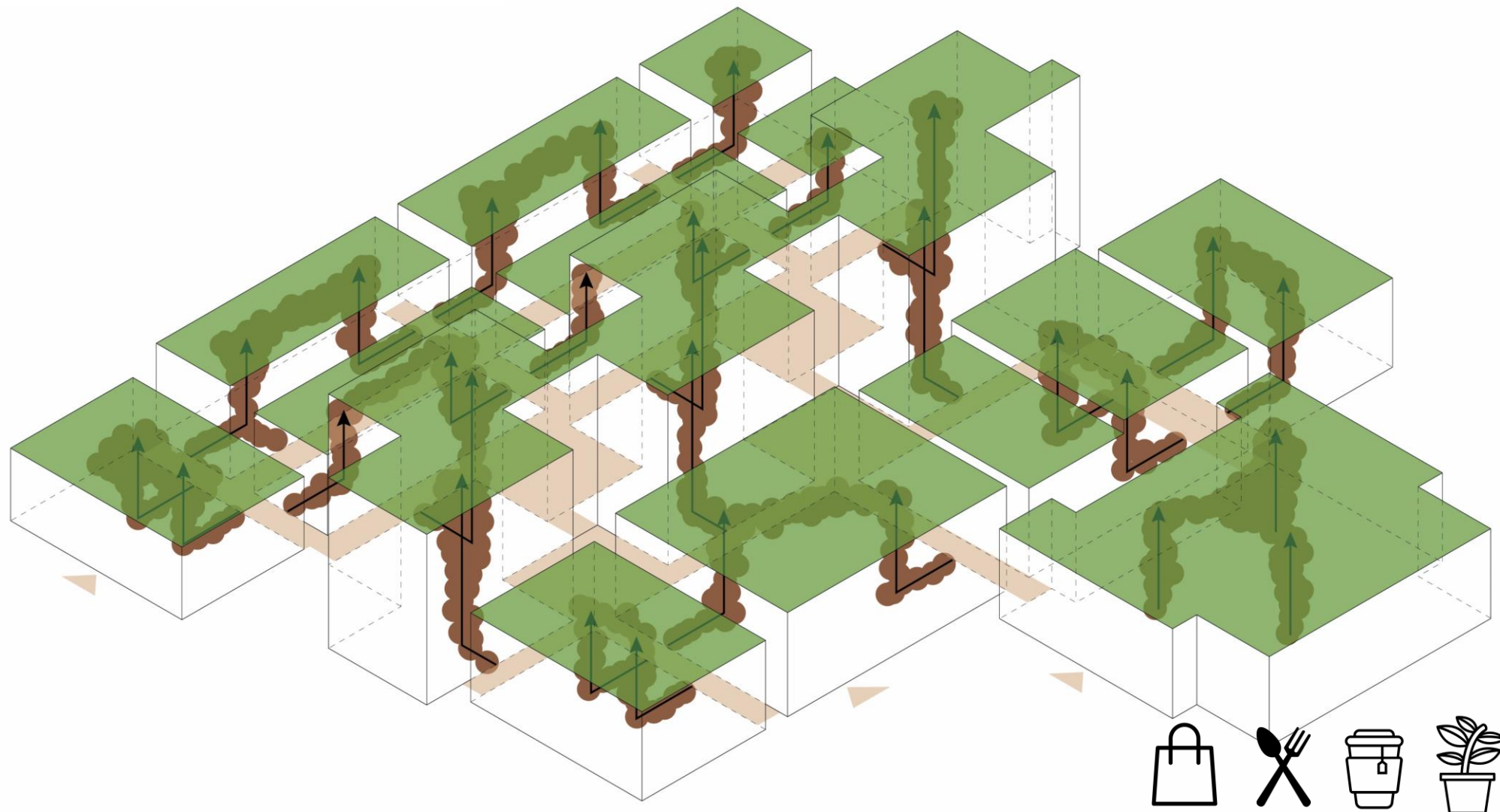

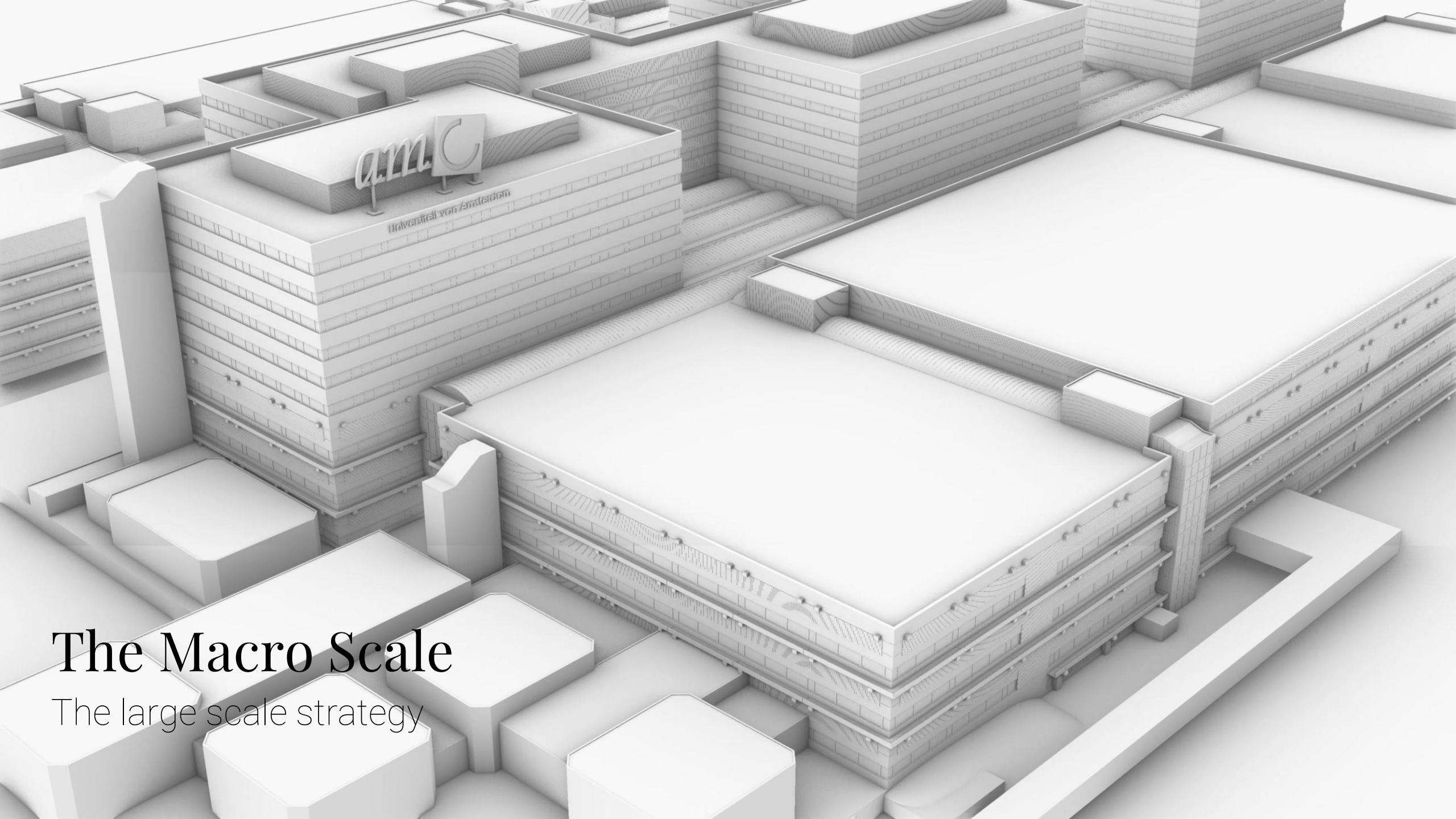

amC
Universiteit van Amsterdam

The Macro Scale

The large scale strategy

Design fragment

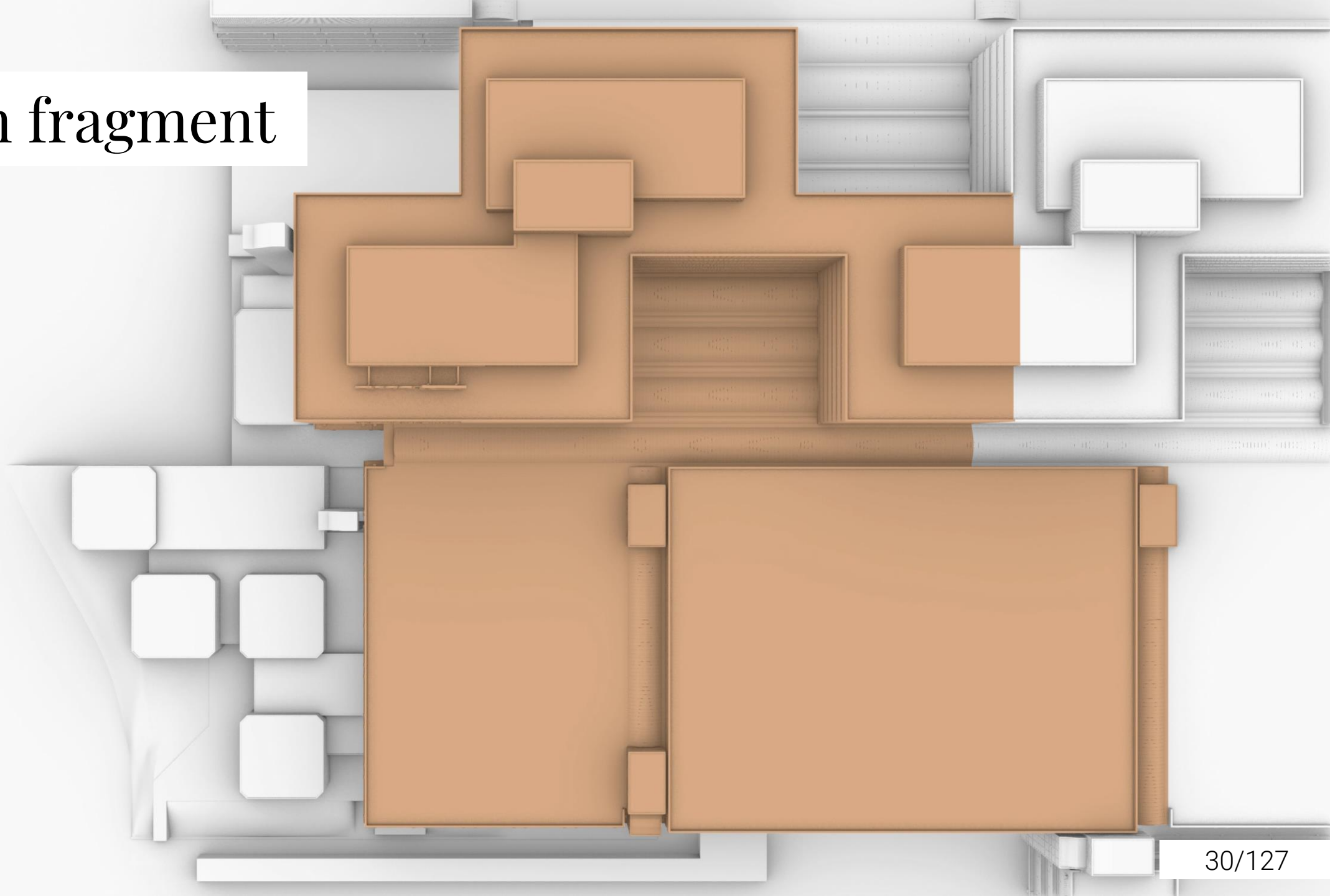

Macro Intervention Strategy

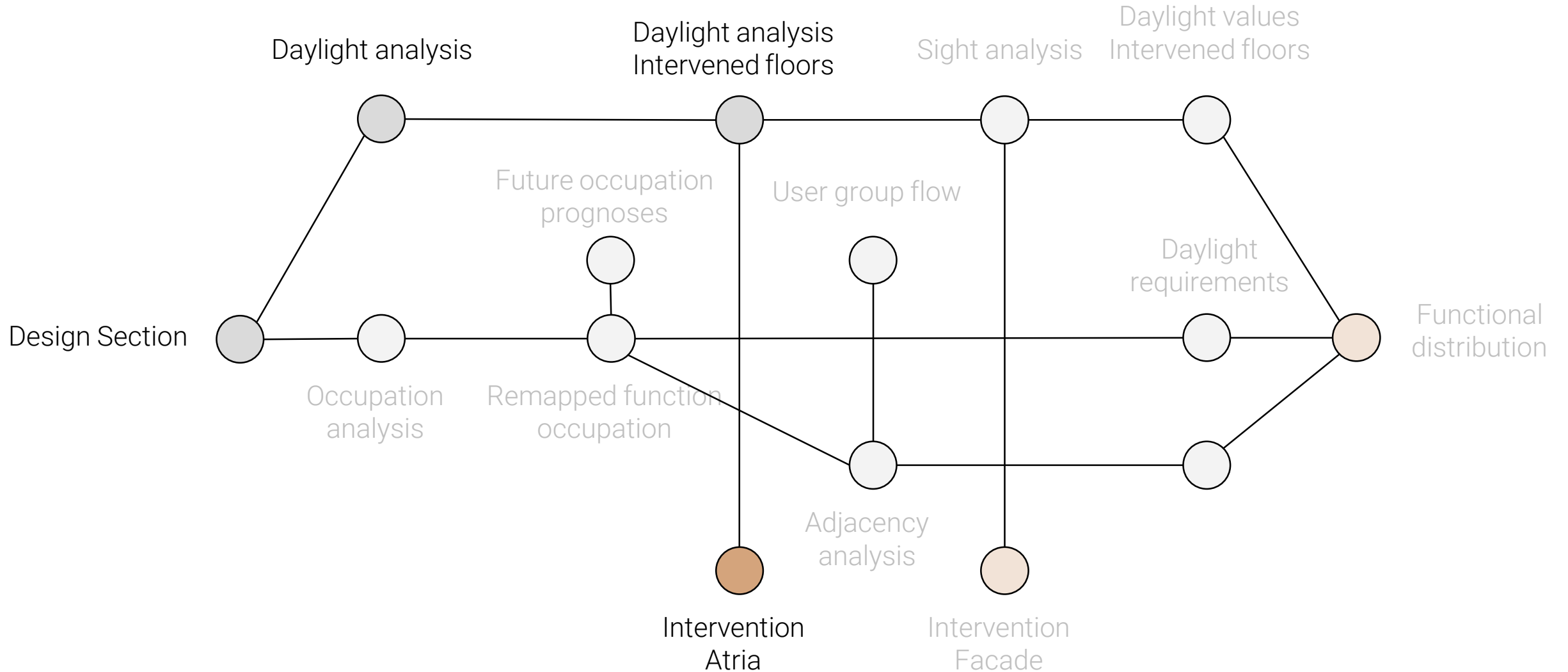

Daylight situation

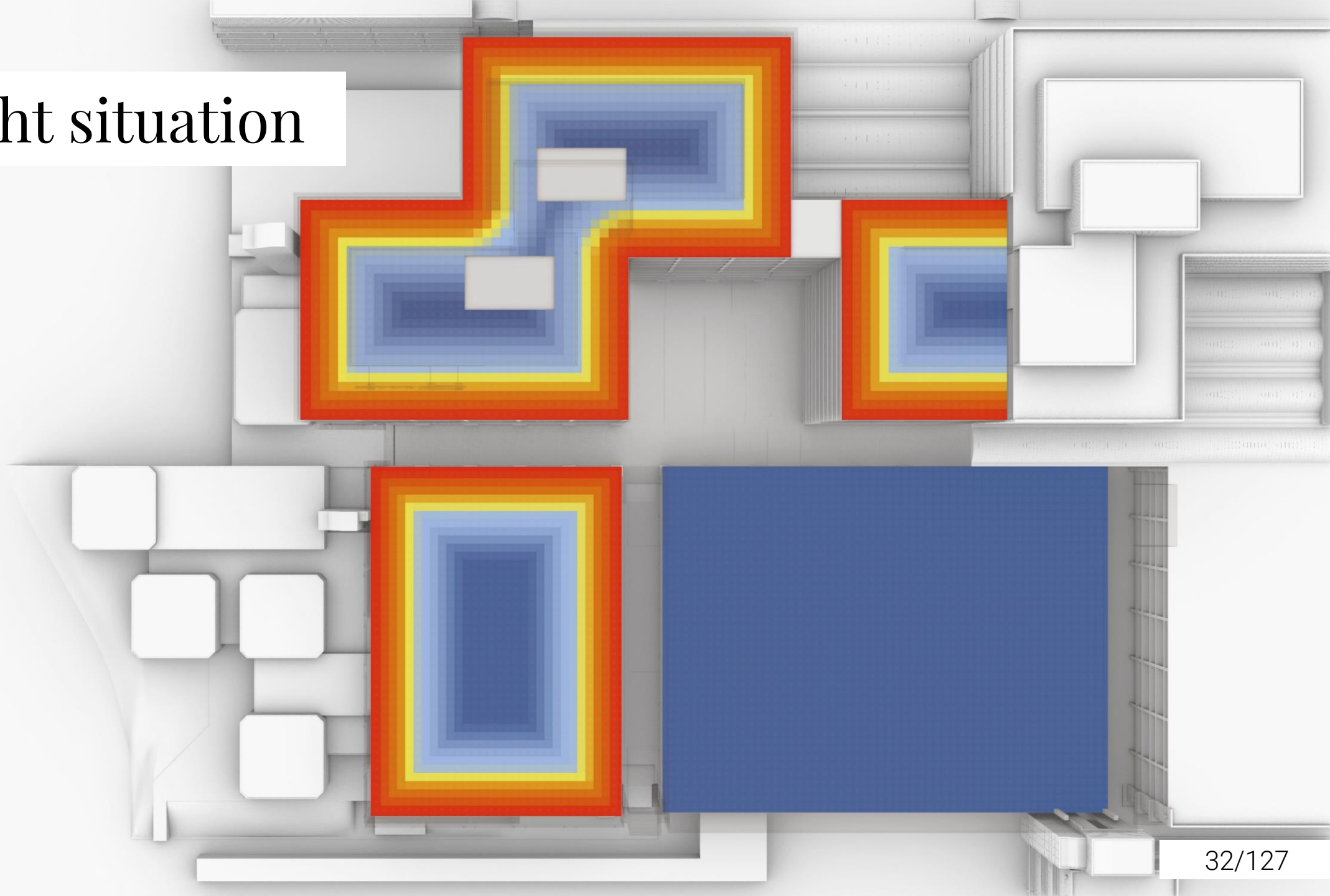

Daylight situation

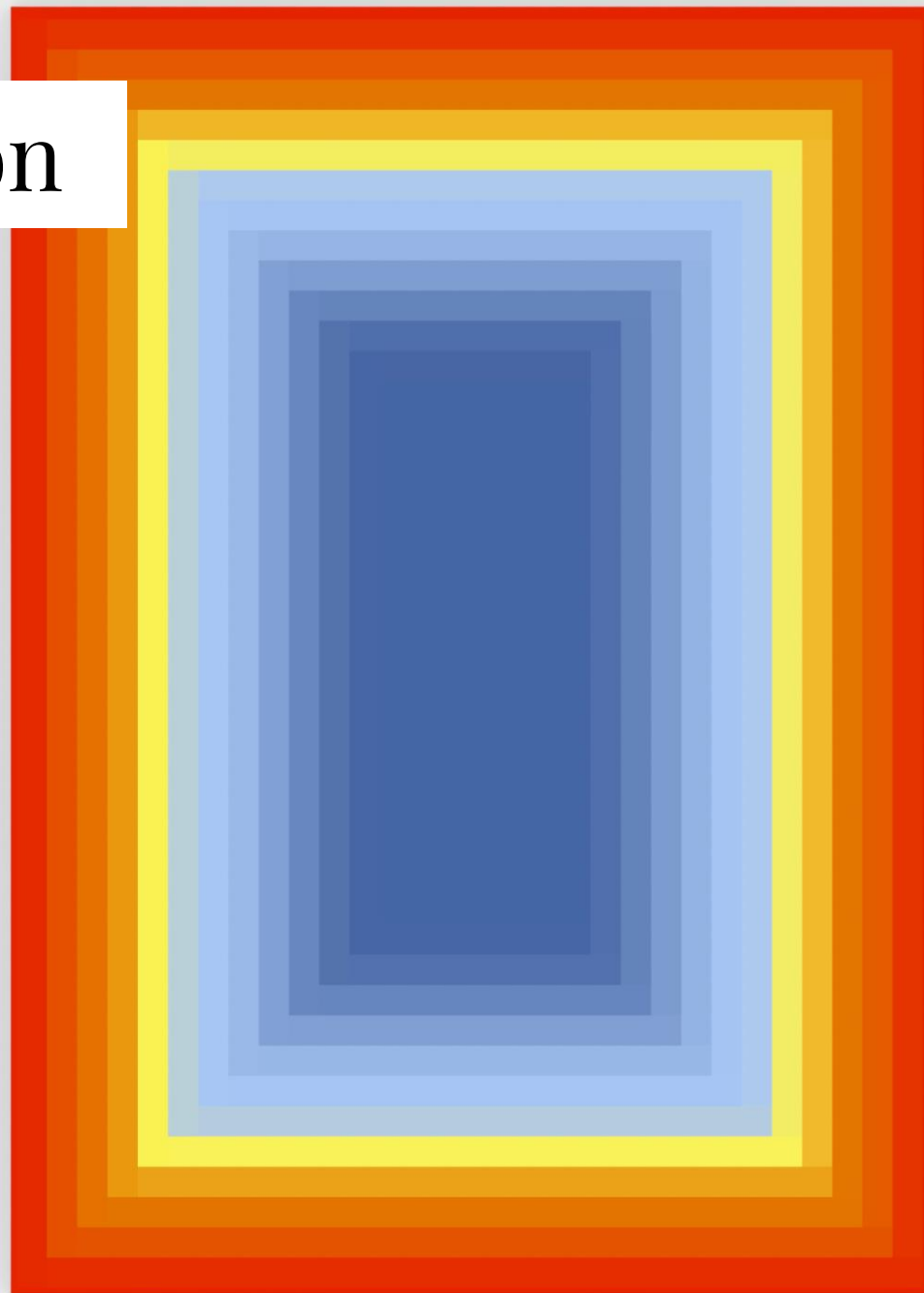

Daylight
Score

Atria
Adjacency

Daylight situation

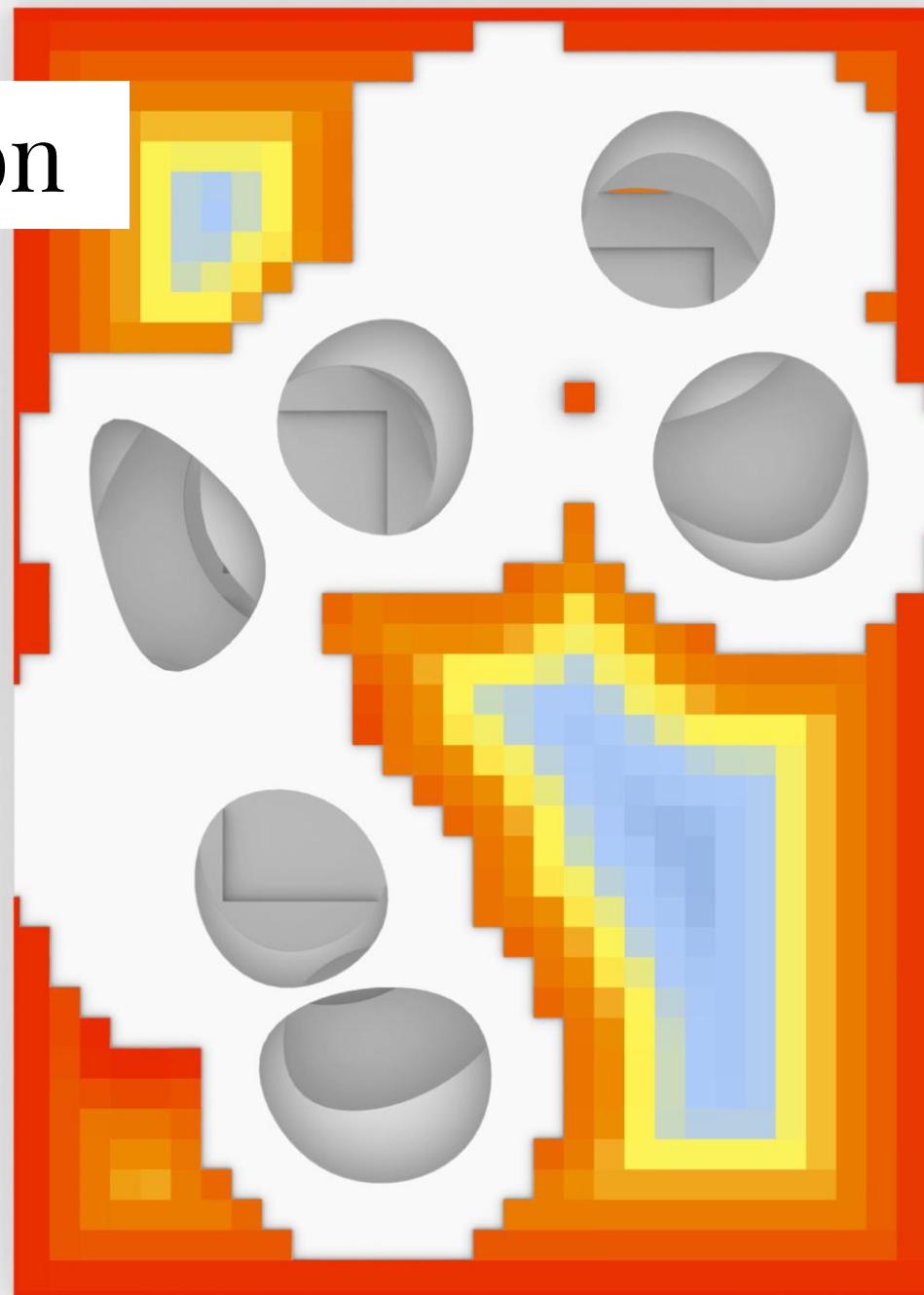

Daylight
Score
3.7637

Atria
Adjacency
3.9149

Daylight situation

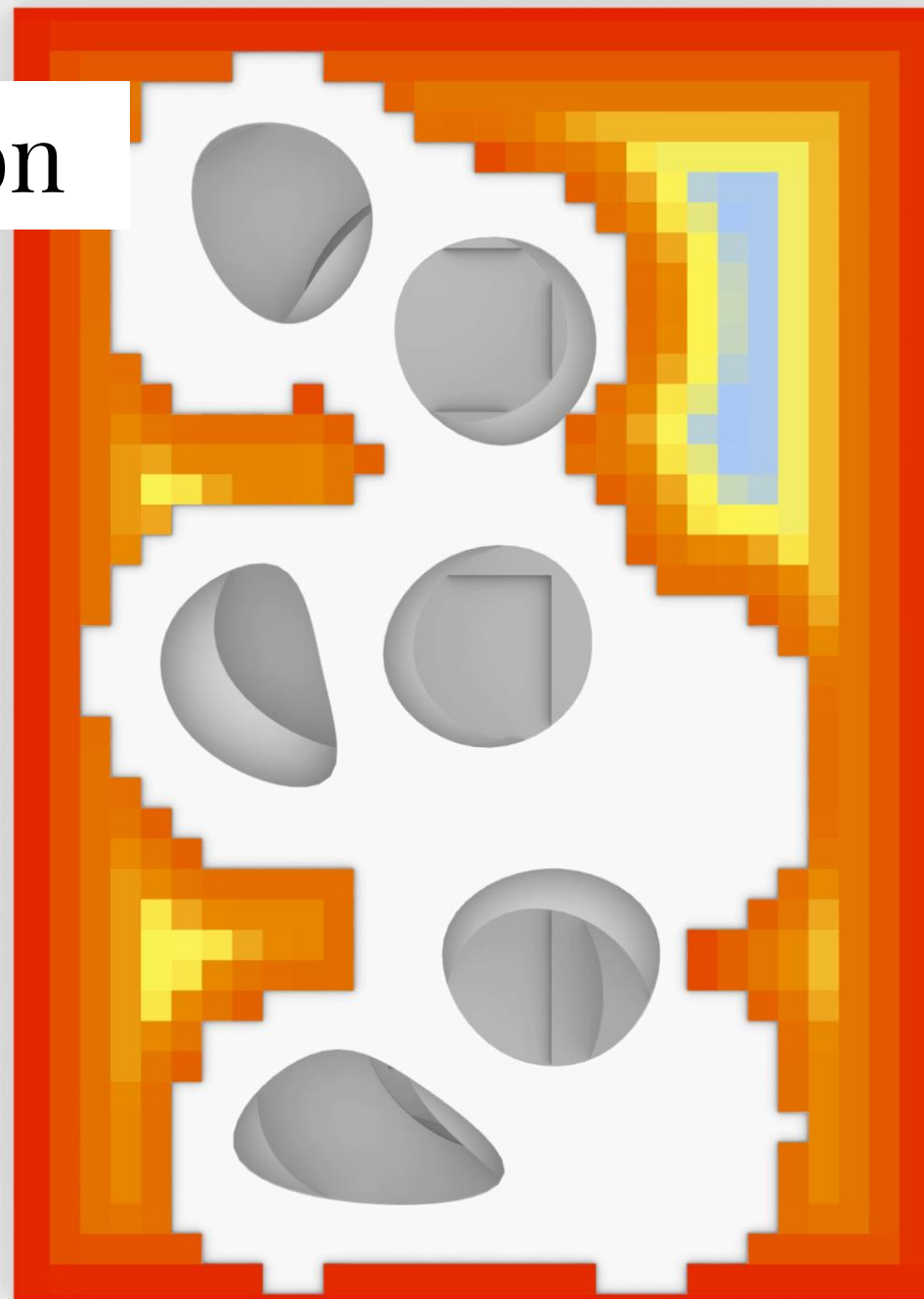

Daylight
Score
3.9309

Atria
Adjacency
3.7270

Daylight situation

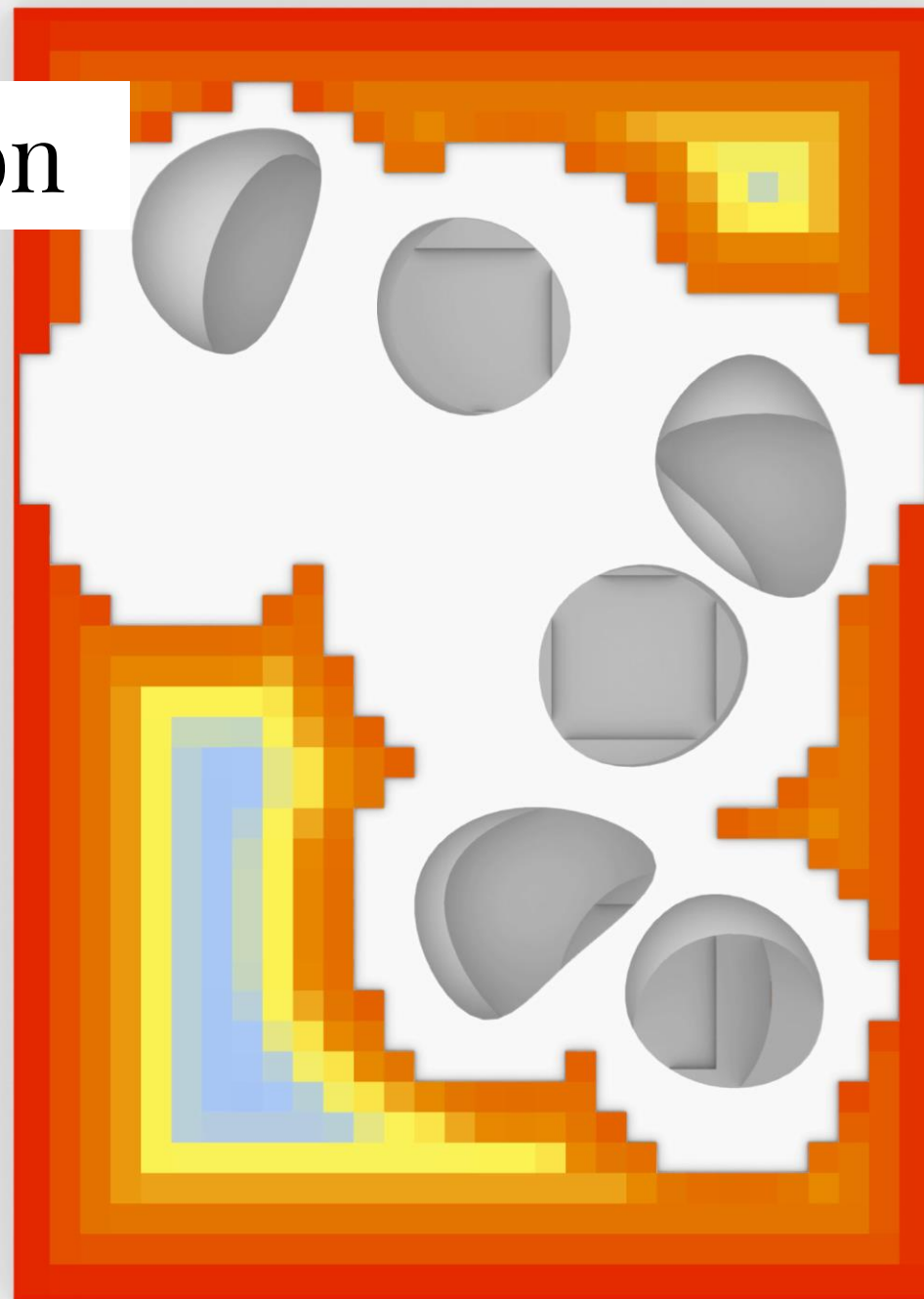

Daylight
Score
3.7319

Atria
Adjacency
3.5753

Daylight atria

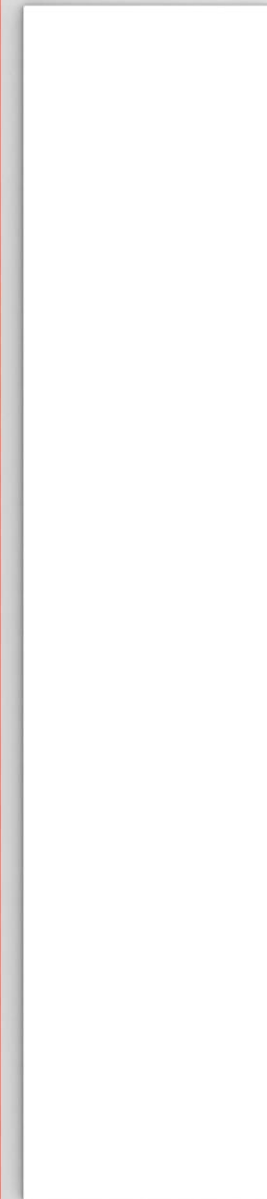
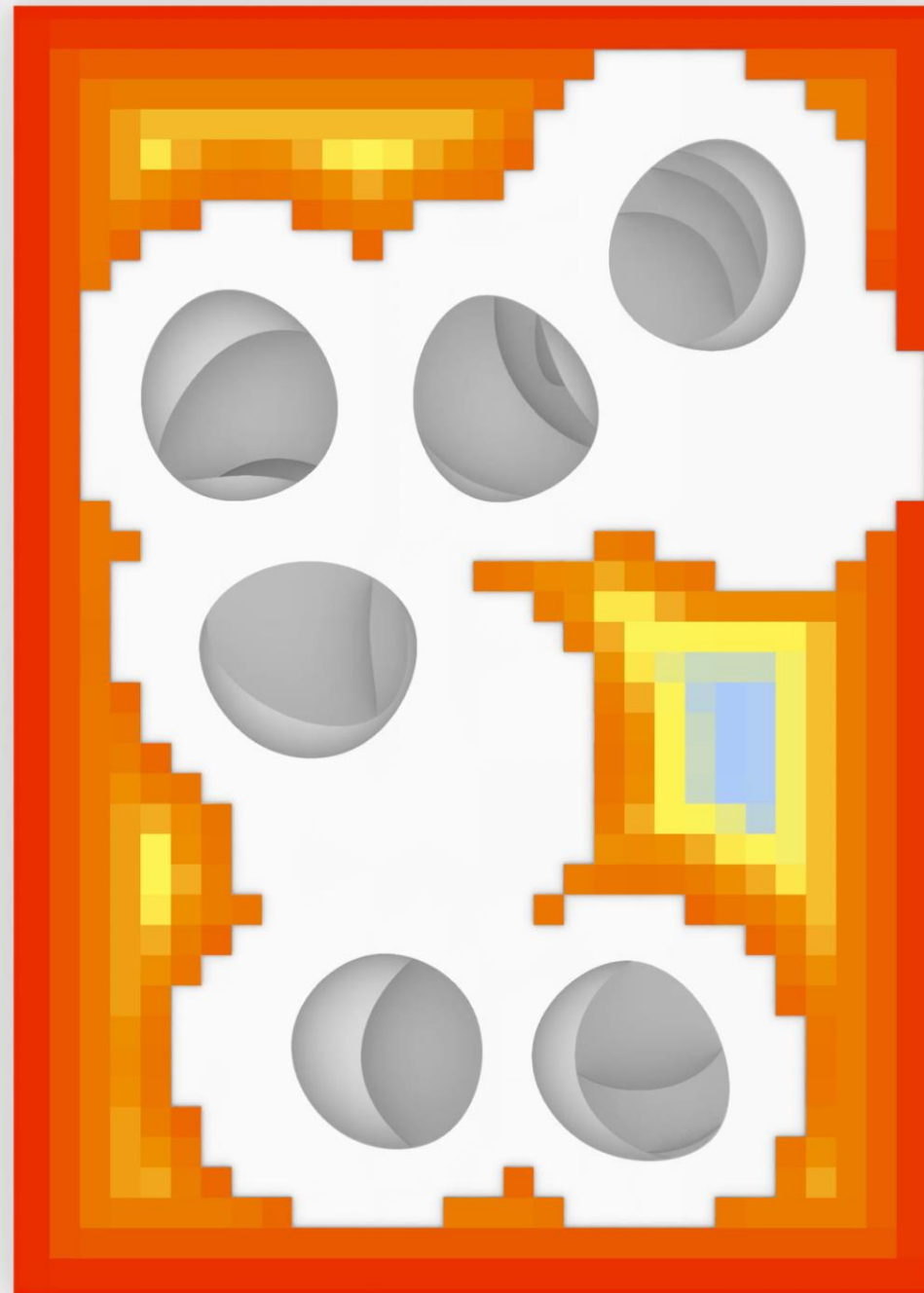

Daylight atria

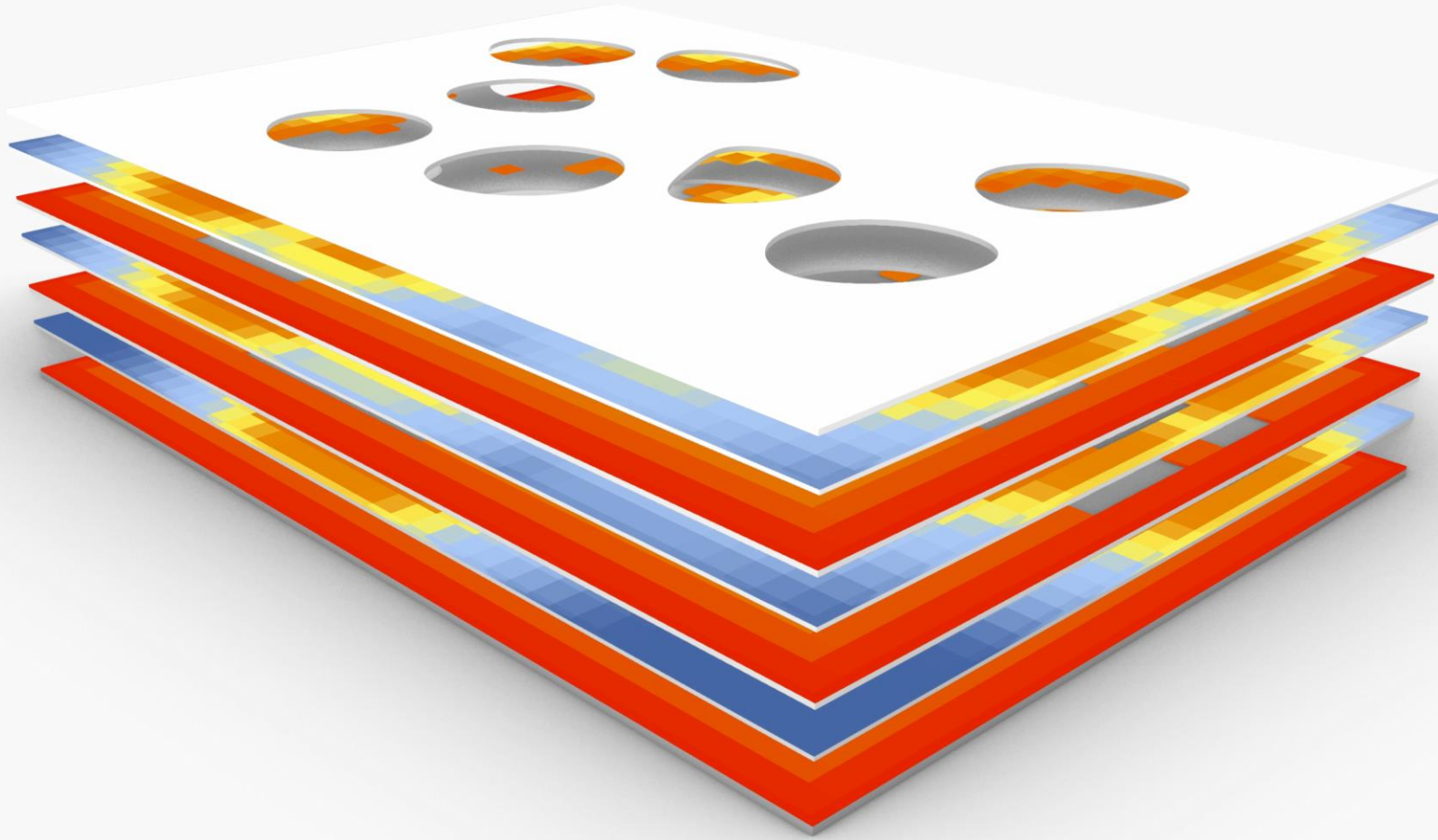

Daylight atria

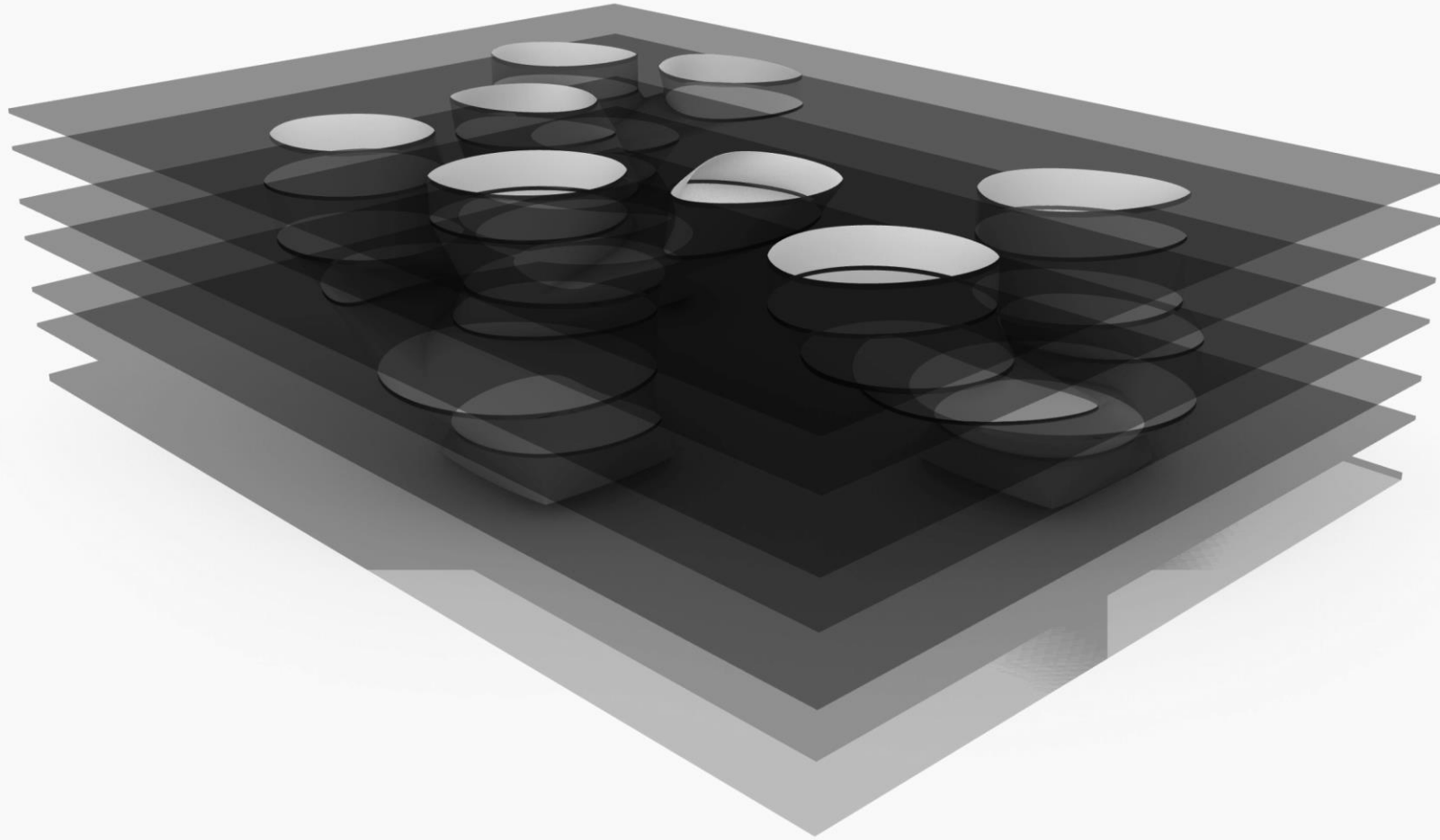

Daylight

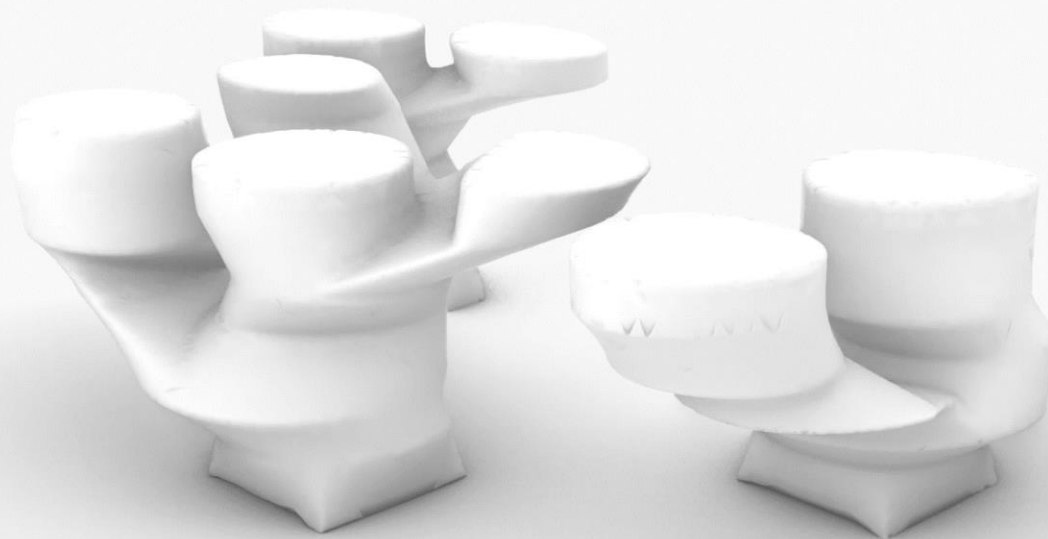

Daylight



Macro Intervention Strategy

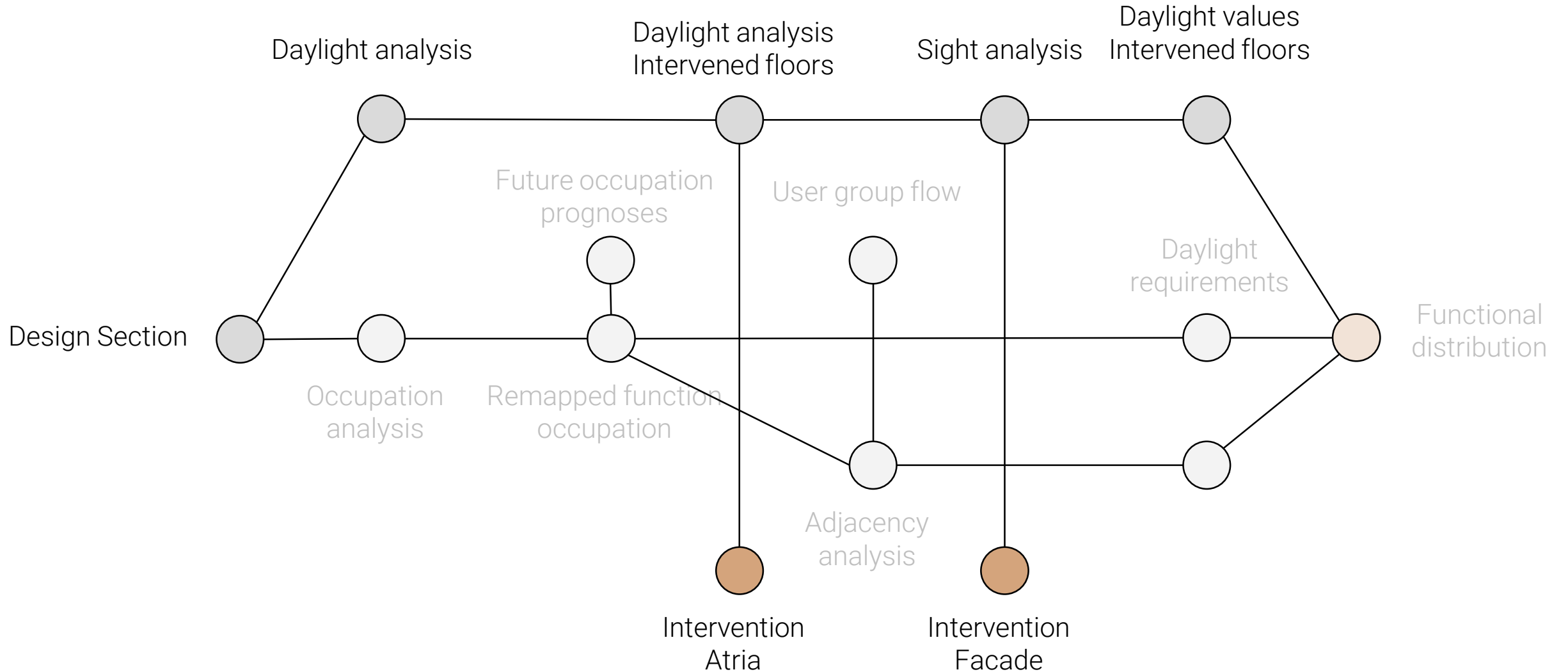

Facade grid



Facade grid

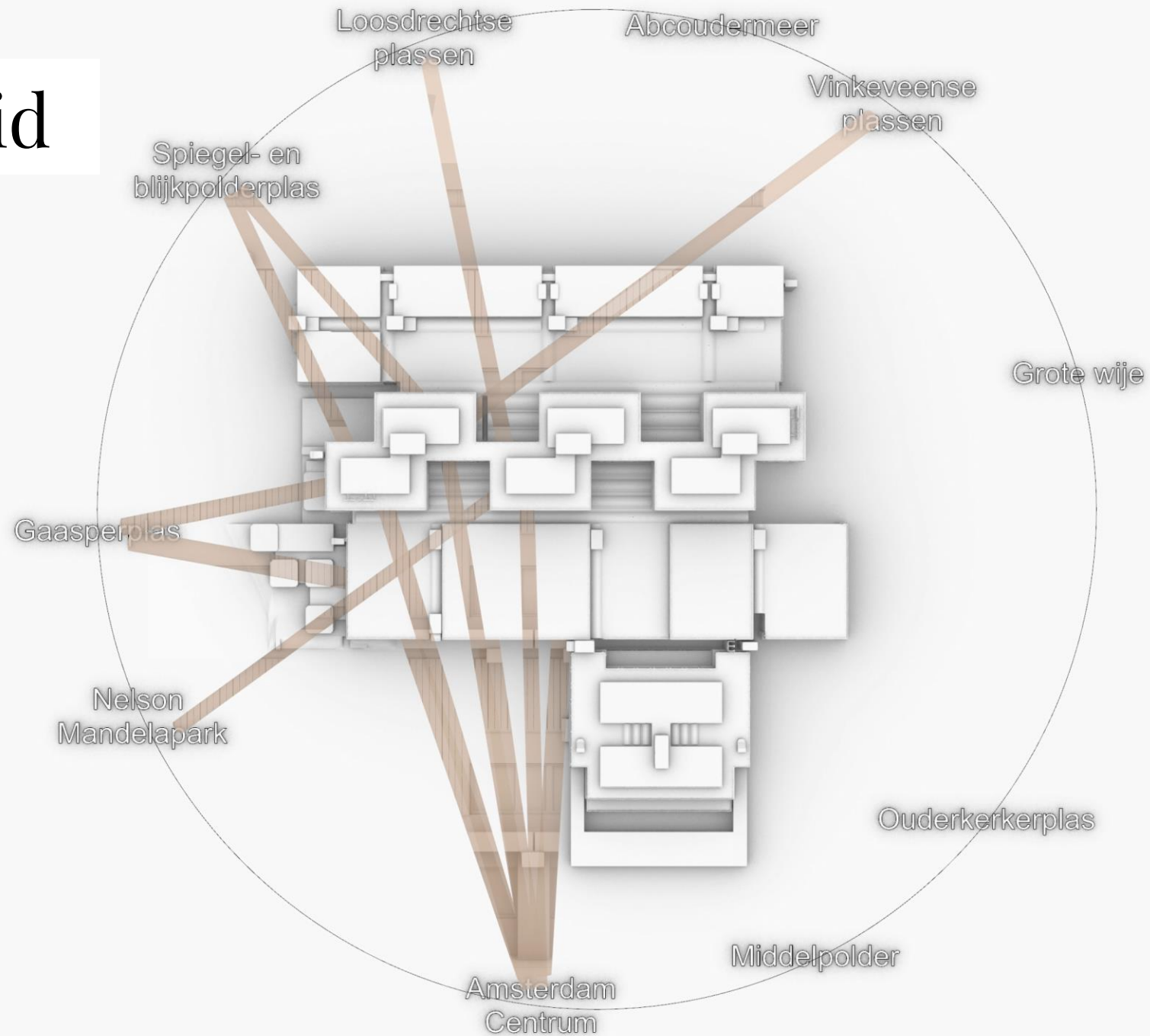

Facade grid

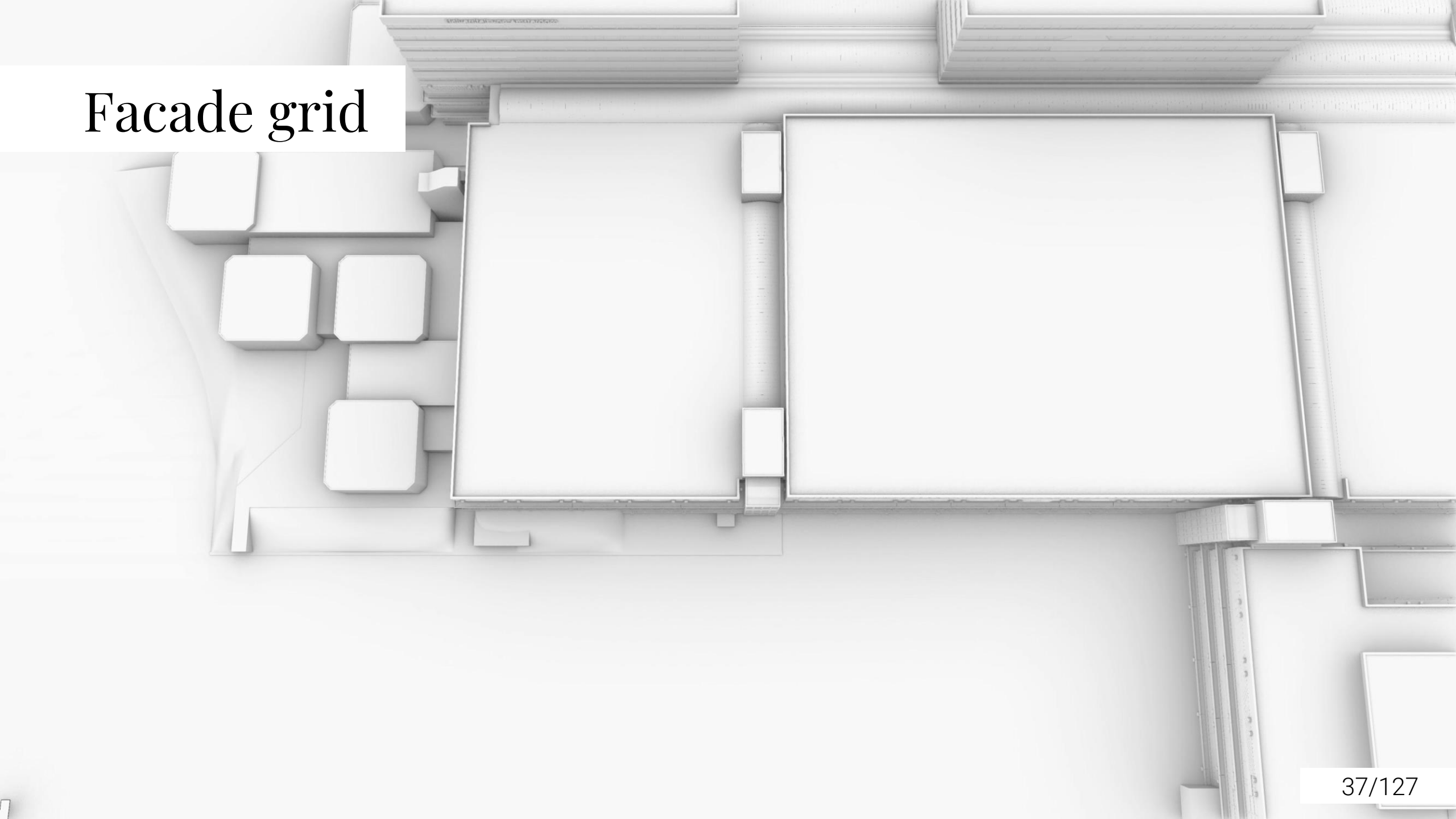

Facade grid

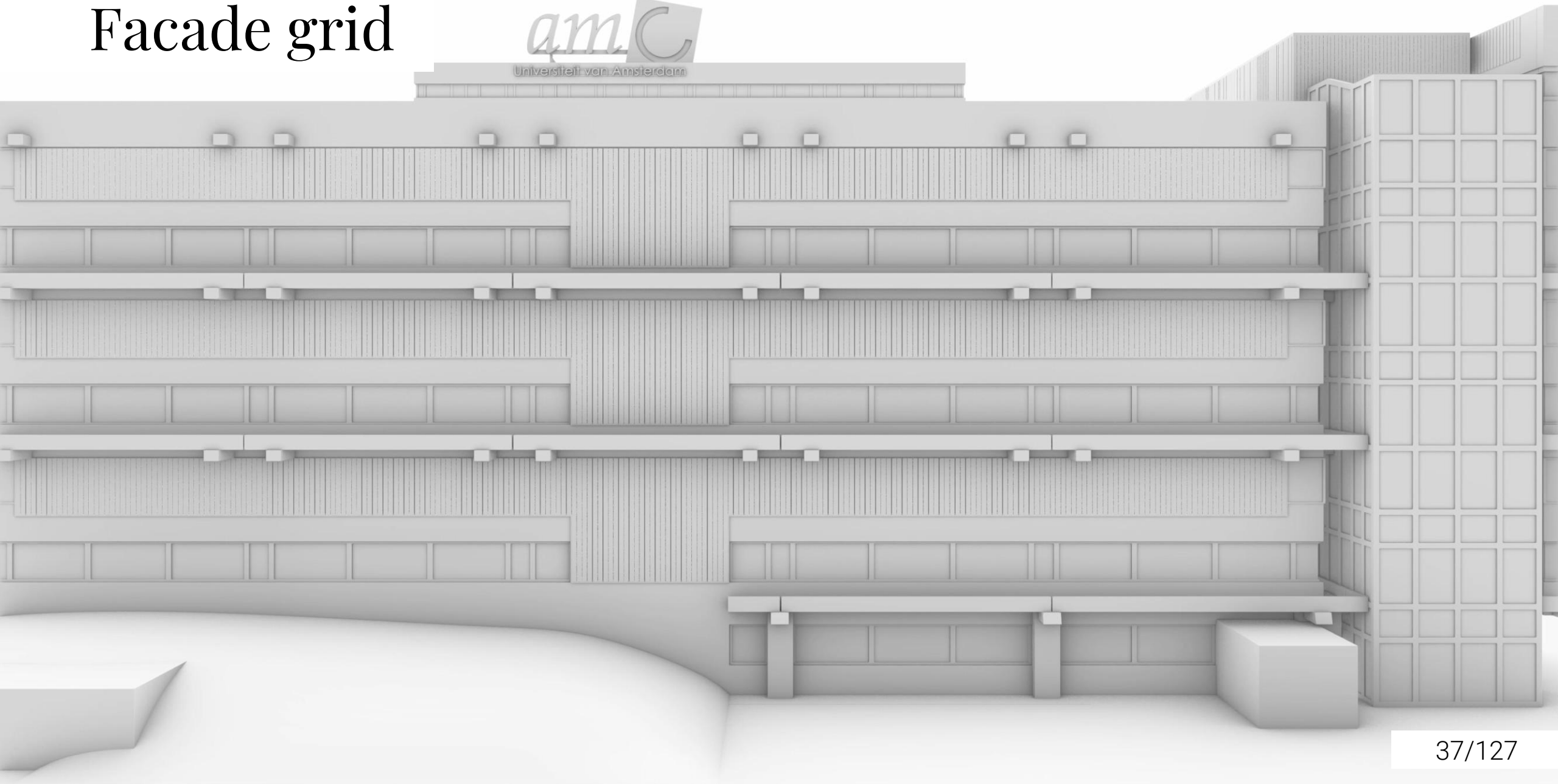

Facade grid

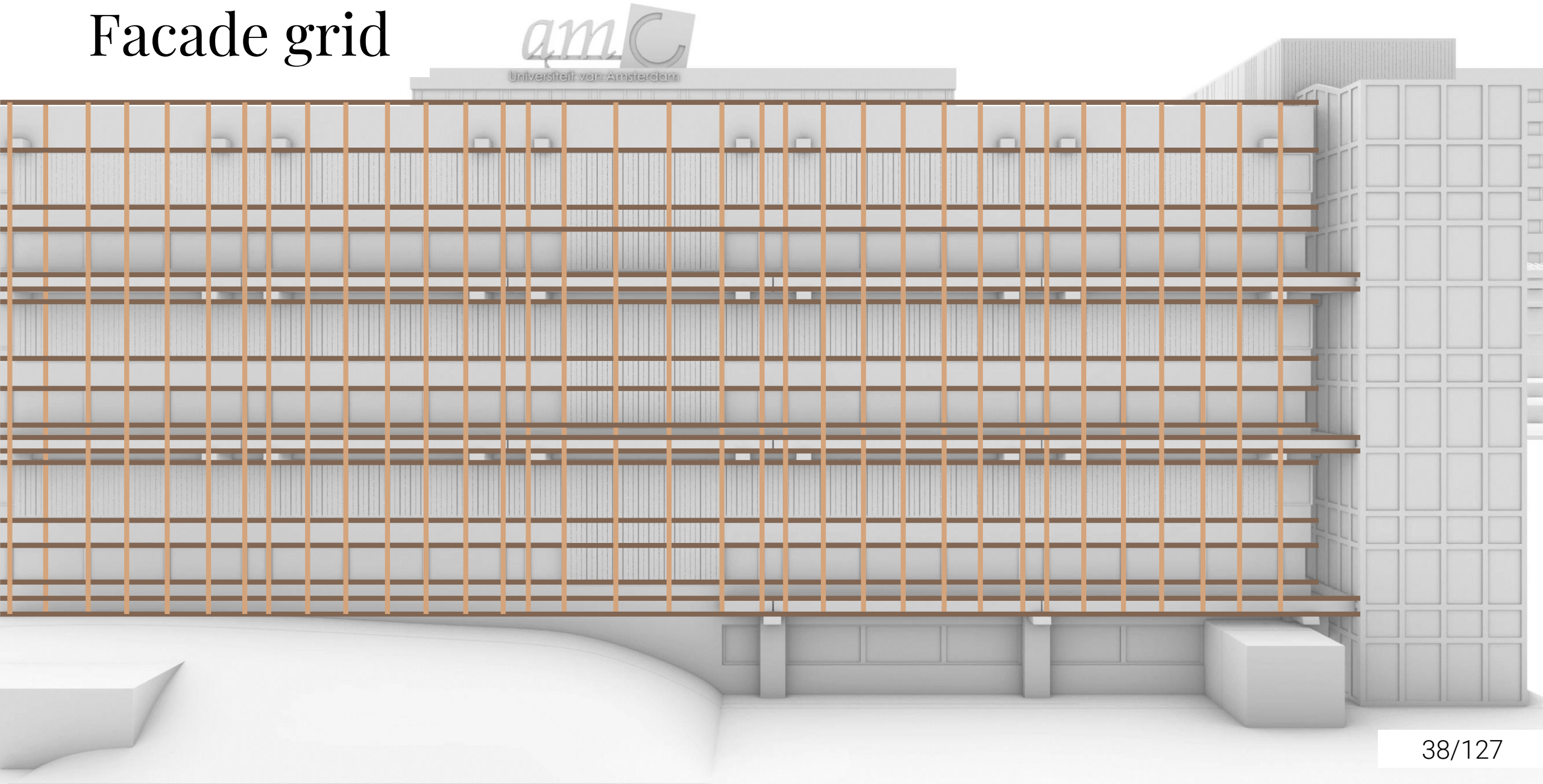

Facade grid

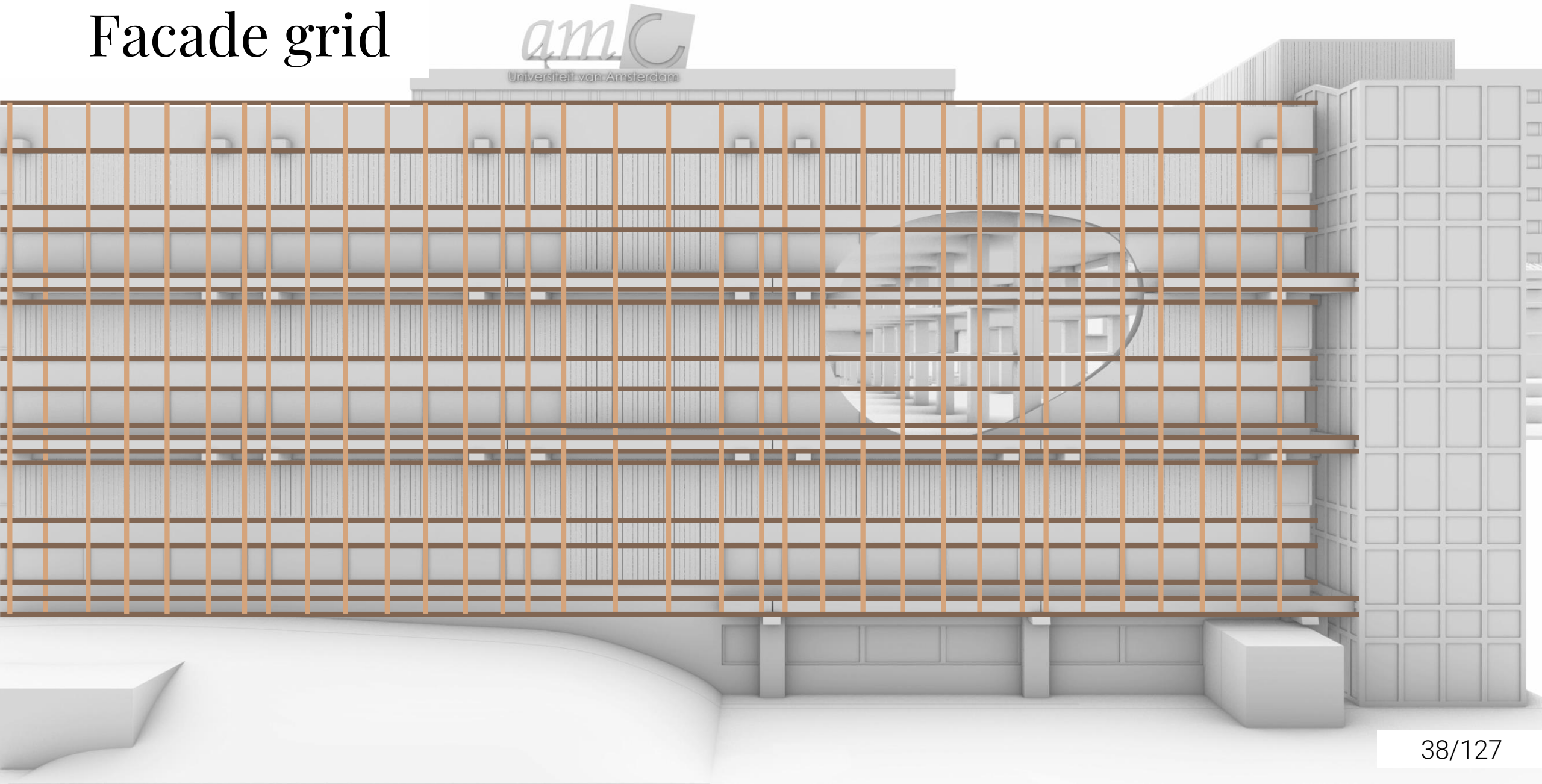

Daylight intervention

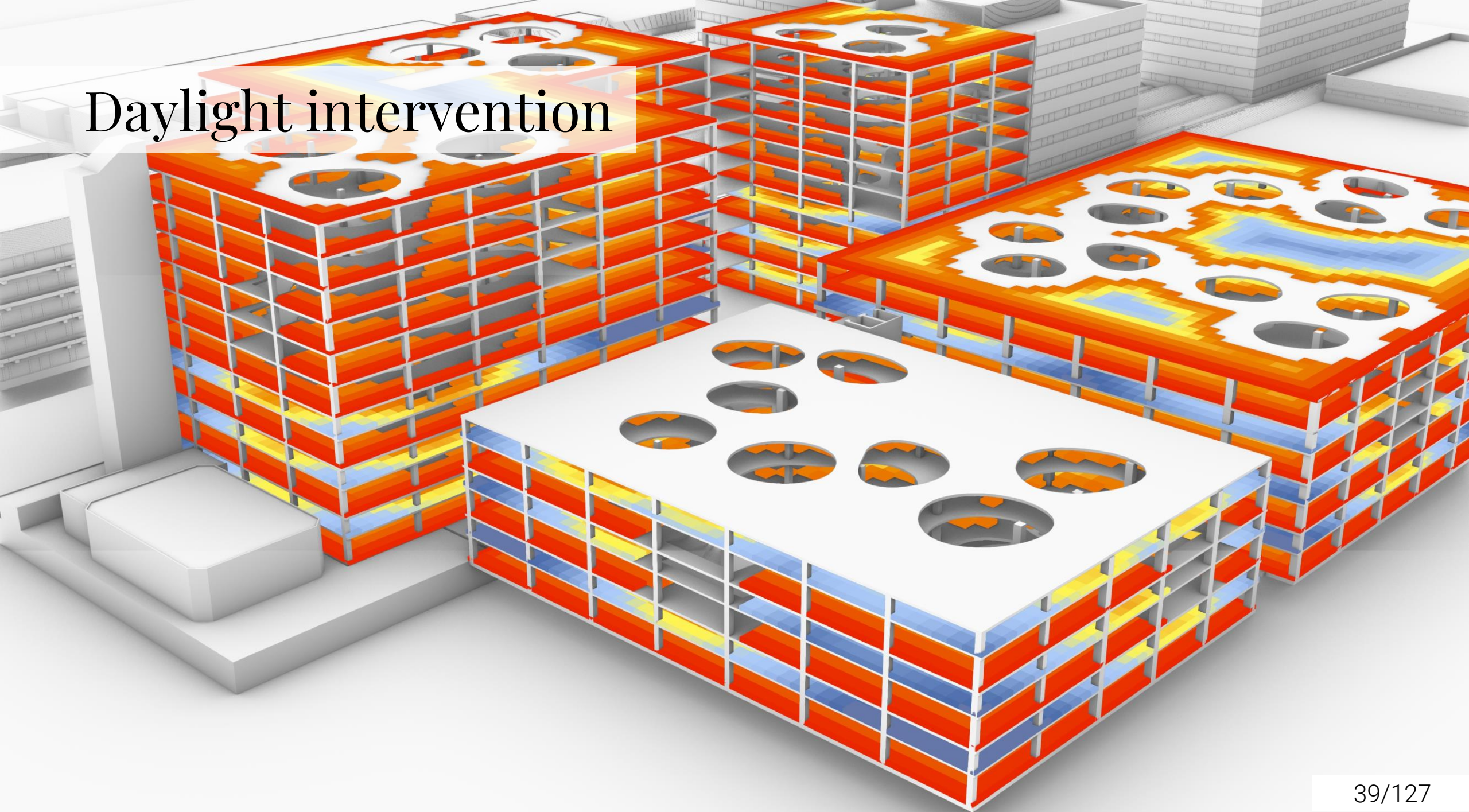

Macro Intervention Strategy

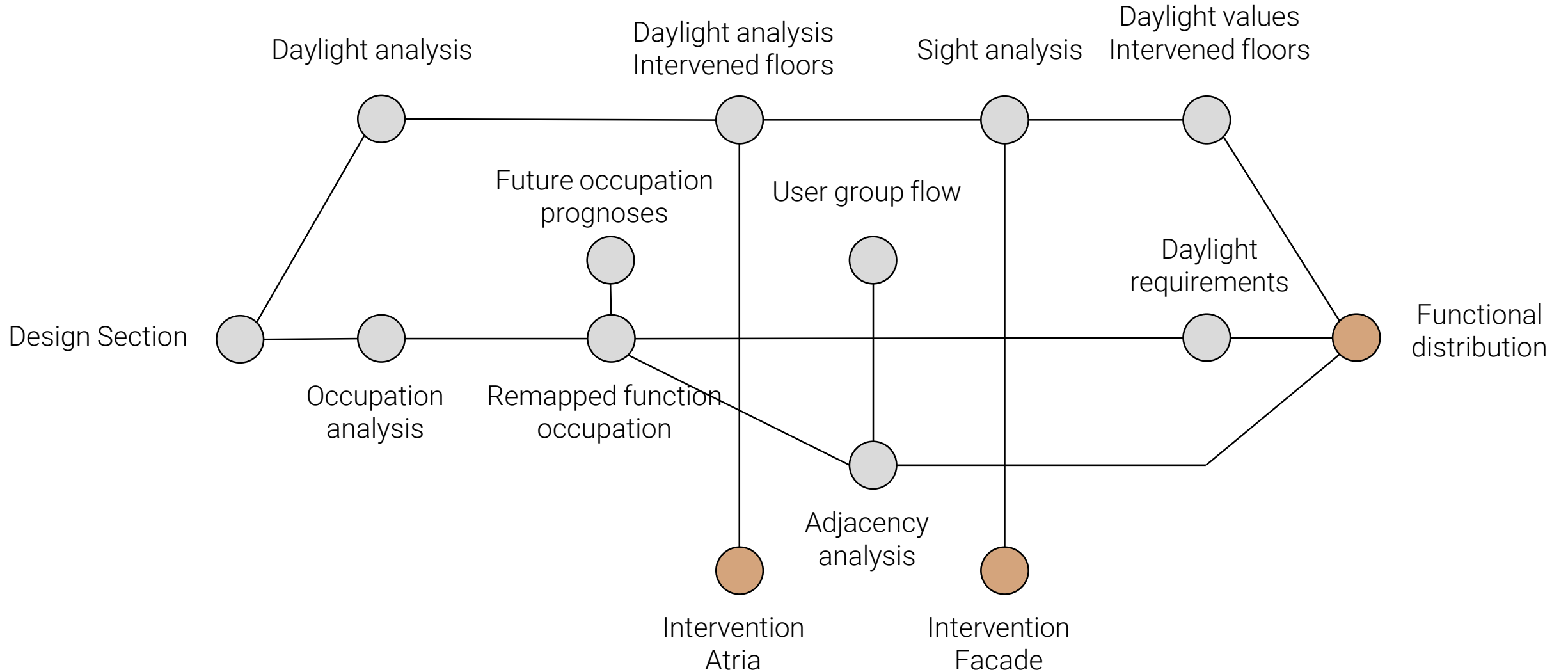

Function occupation

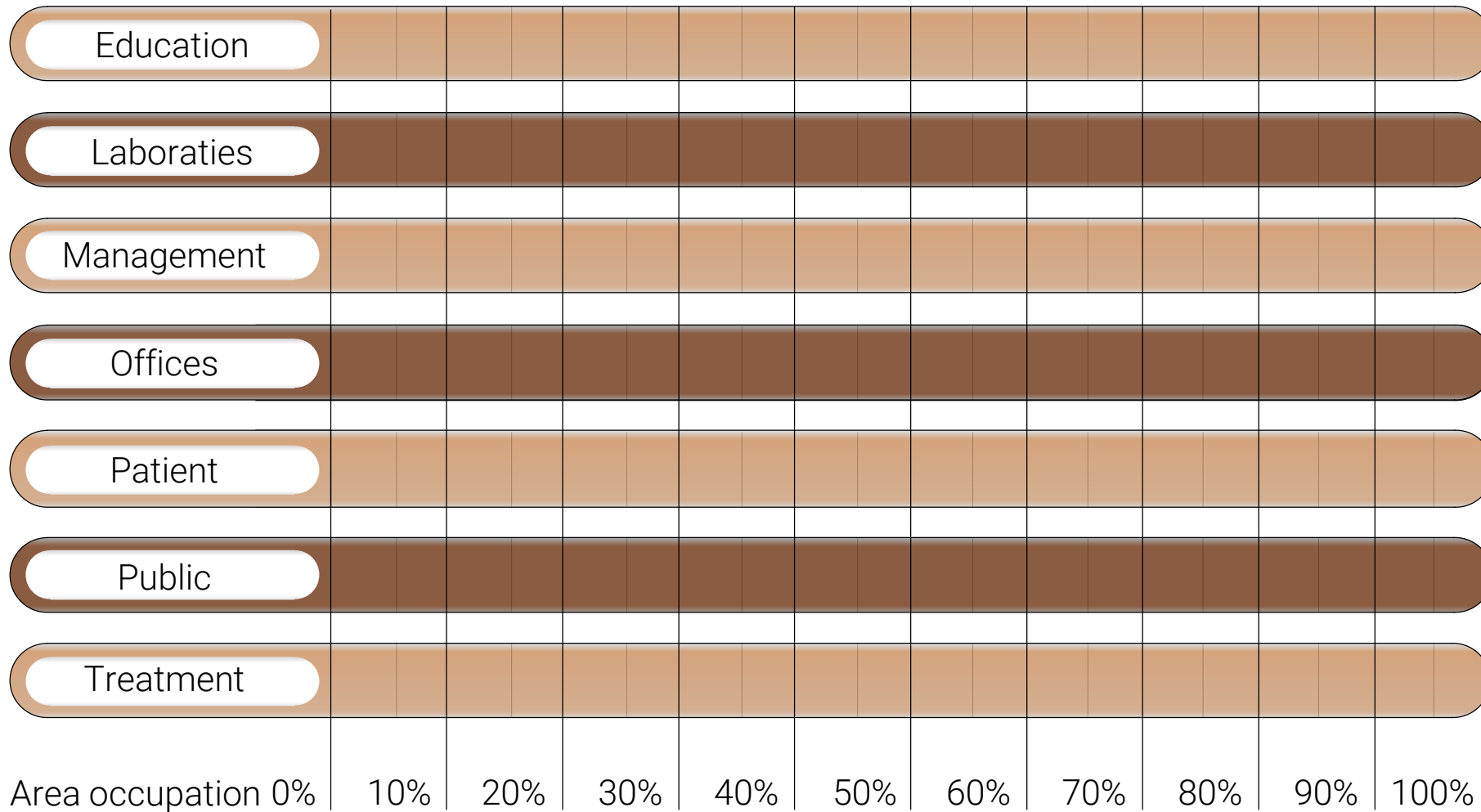

Occupation analysis

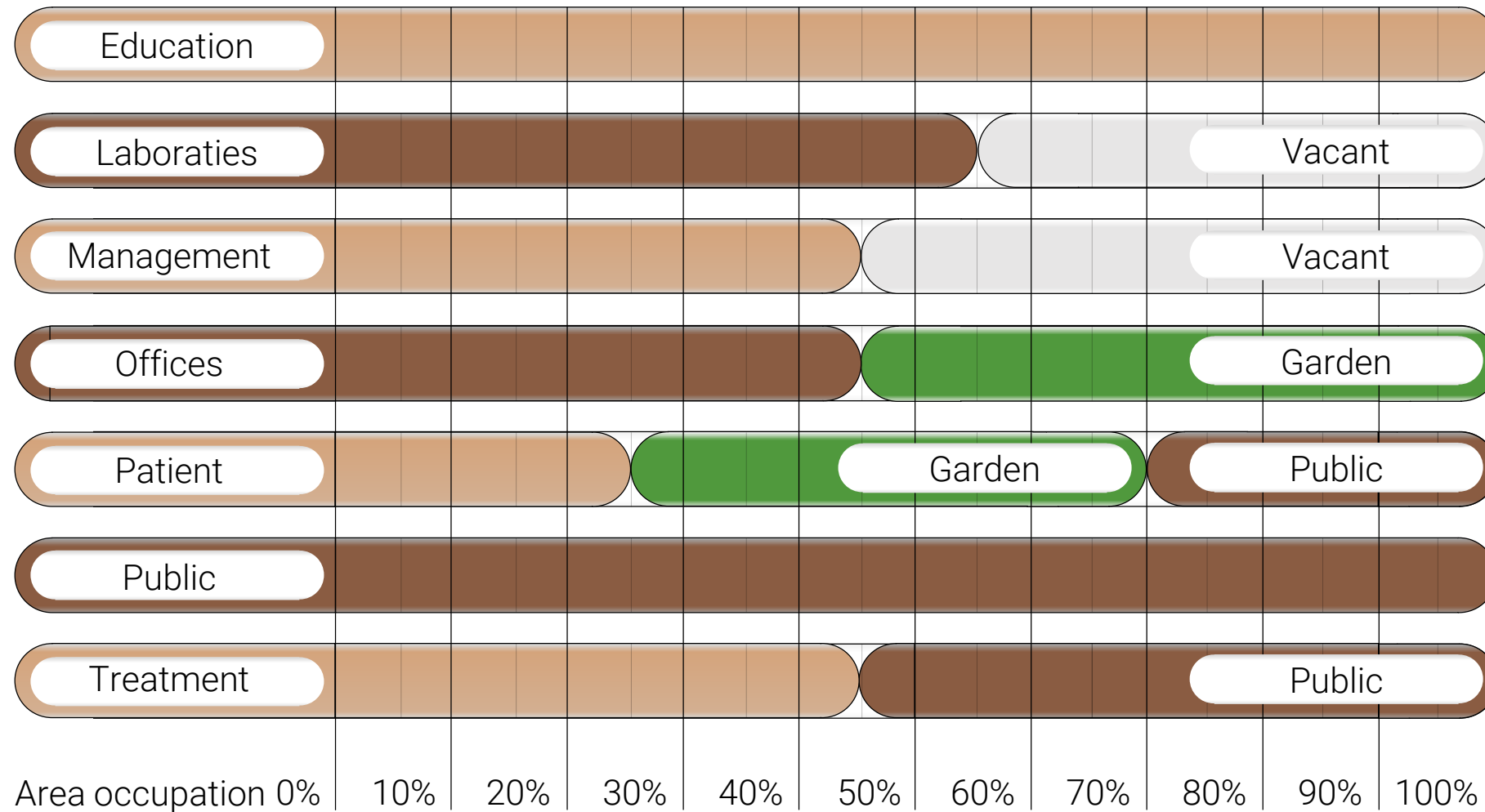

Occupation analysis

Macro Scale

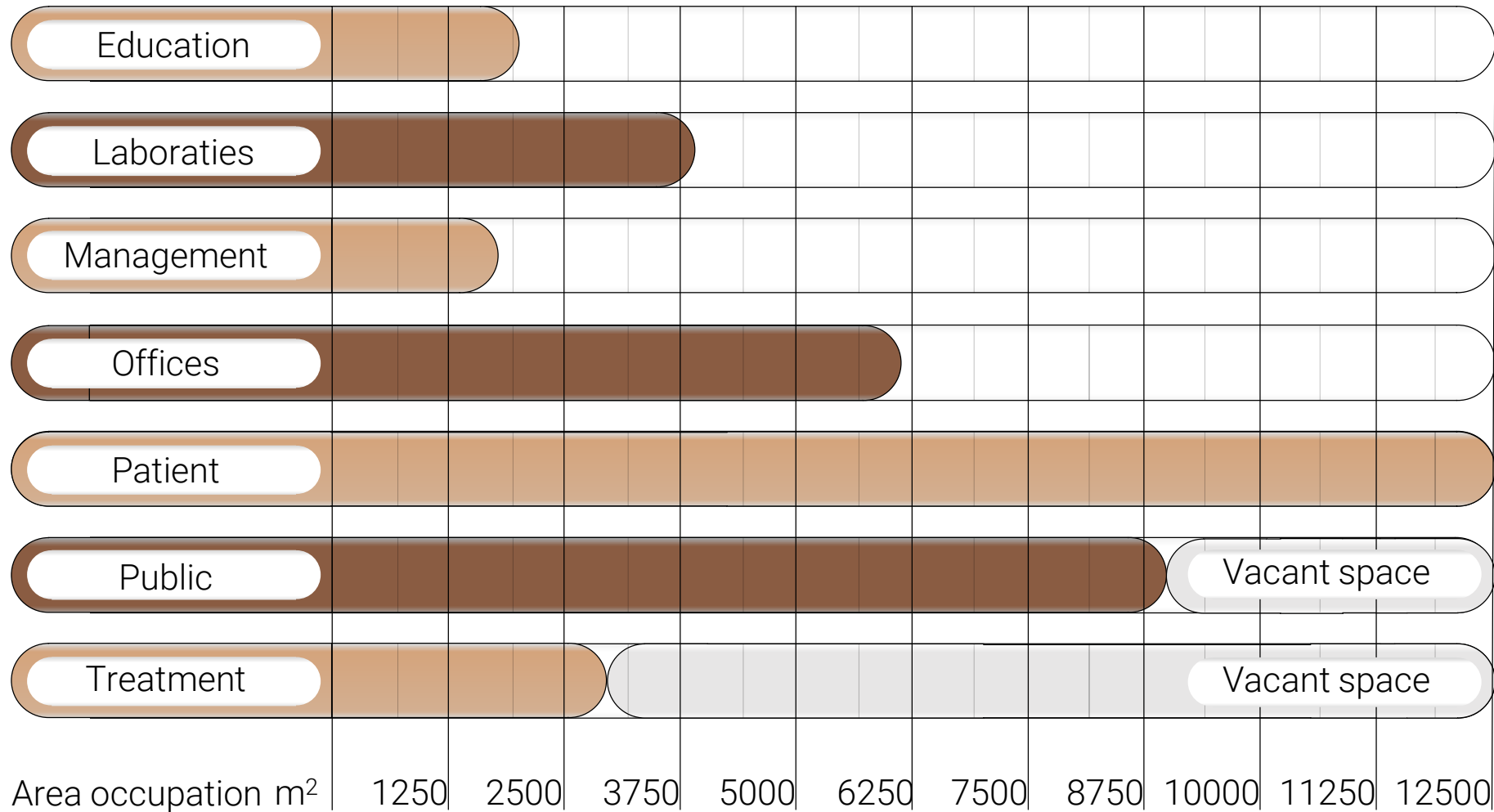

Normally
Total area
52.500 m²

Remapped
Total area
41.750 m²

Vacant space
Total area
10.750 m²

People flow

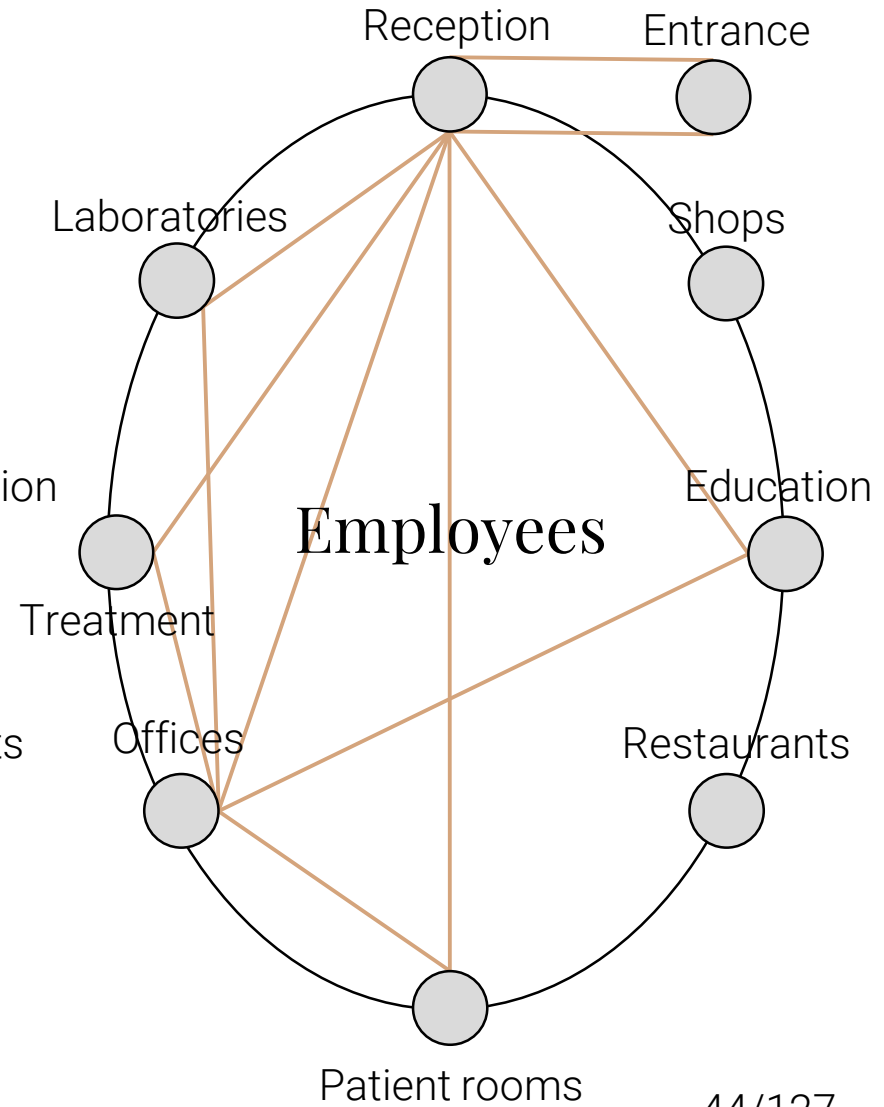
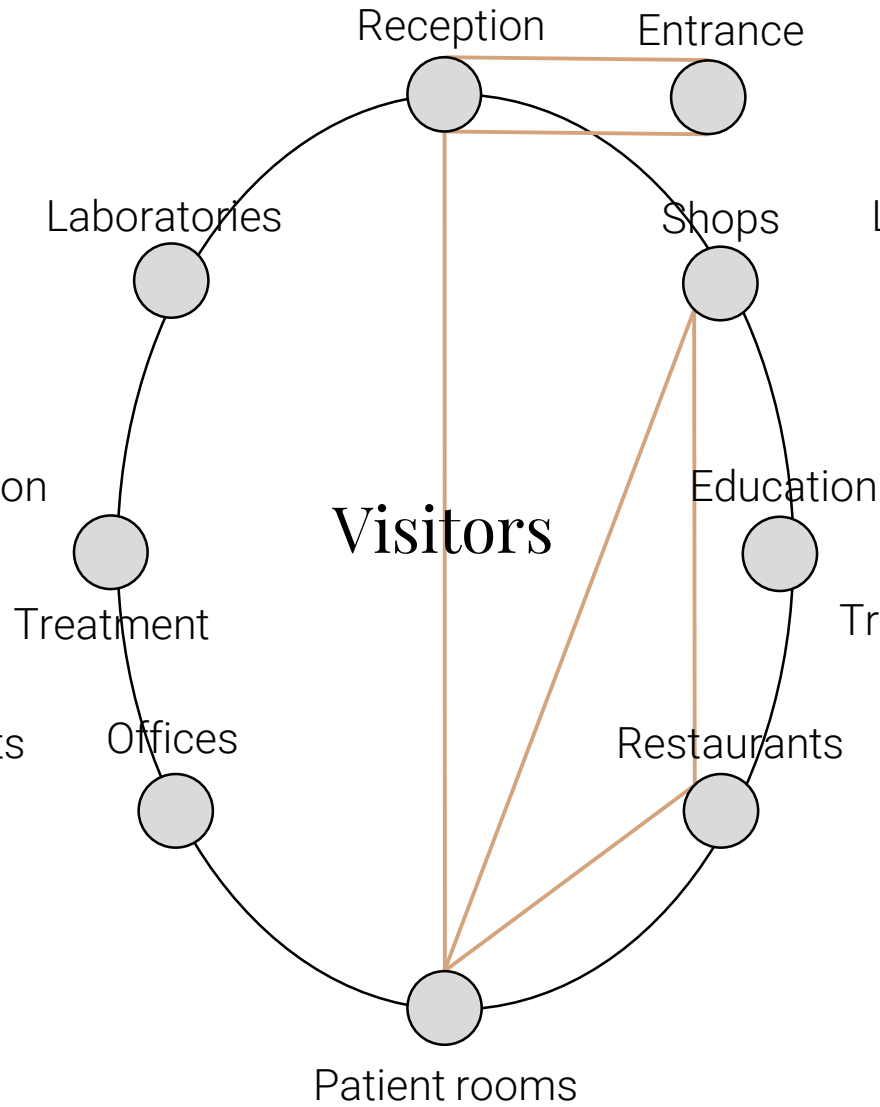
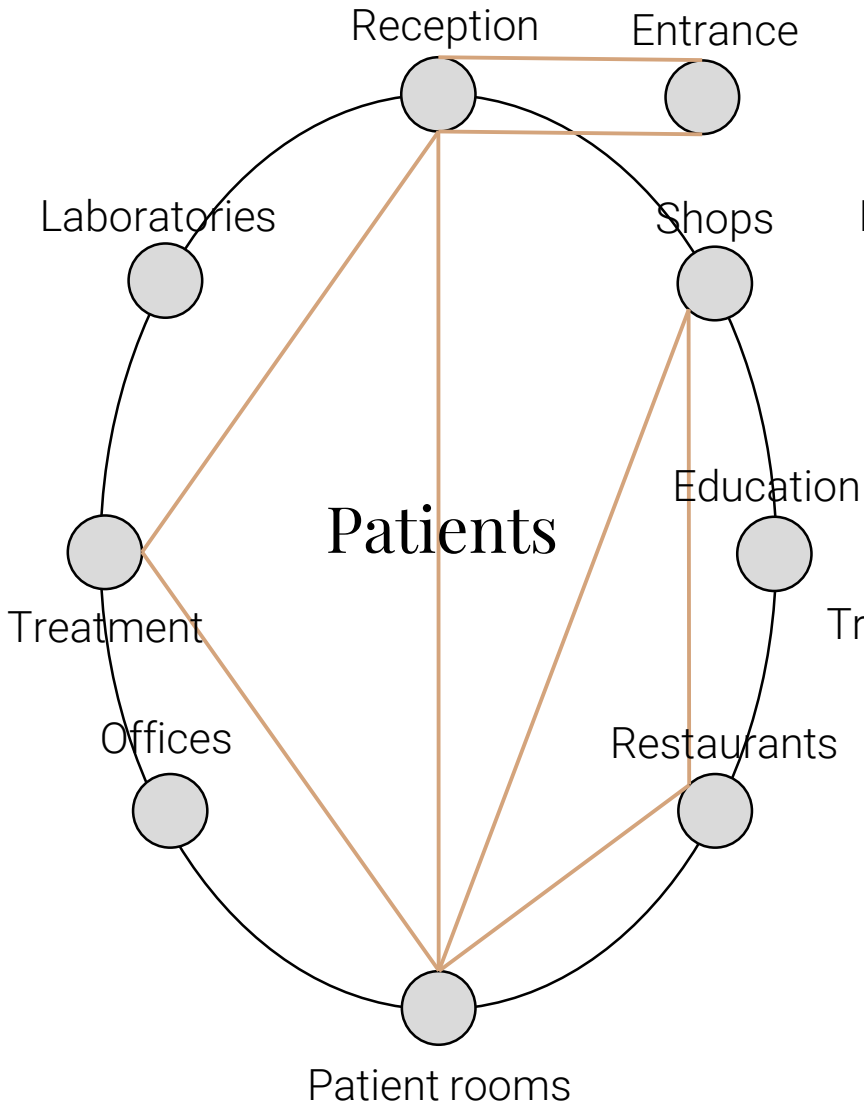

Adjacency matrix

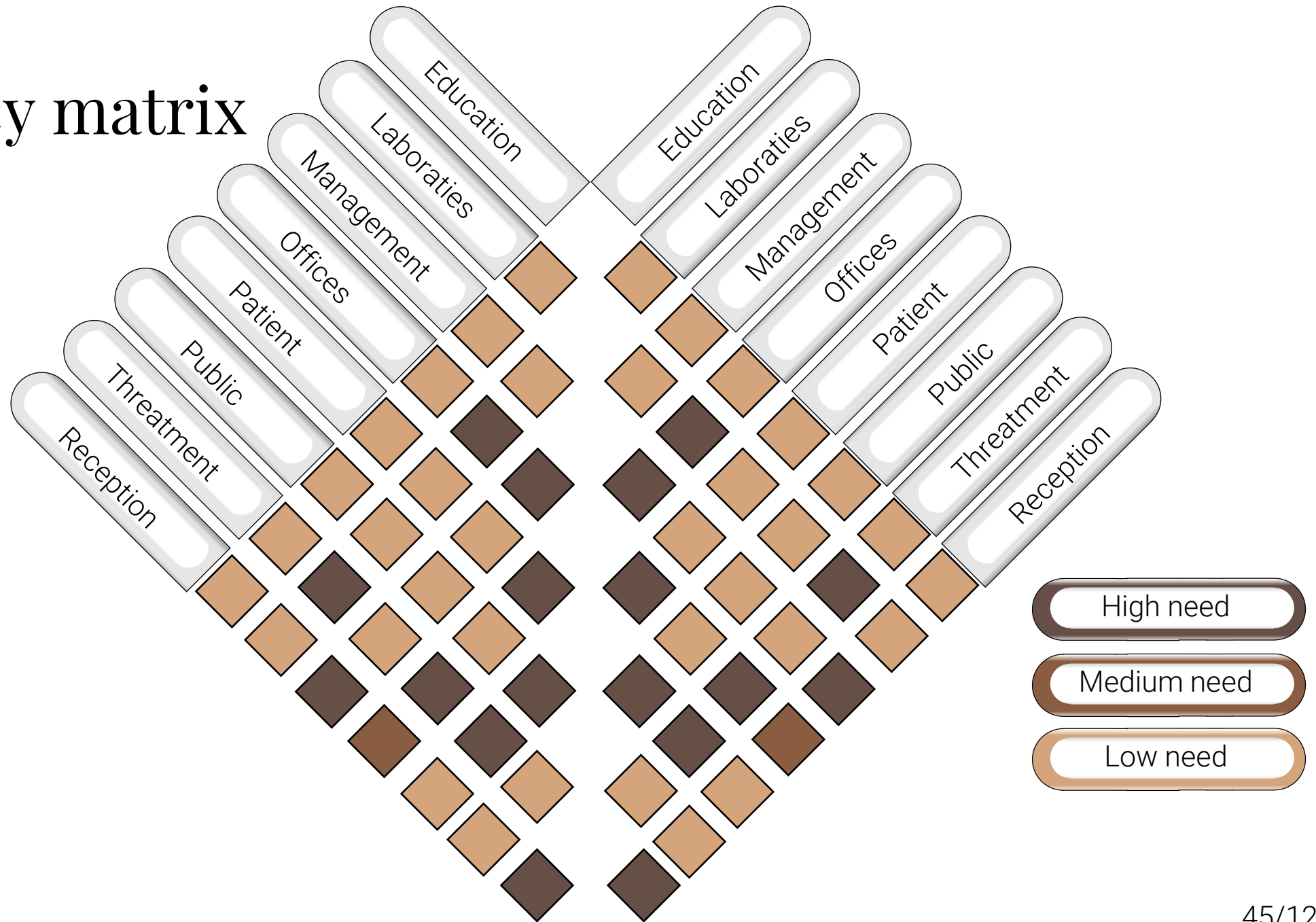

Daylight requirements

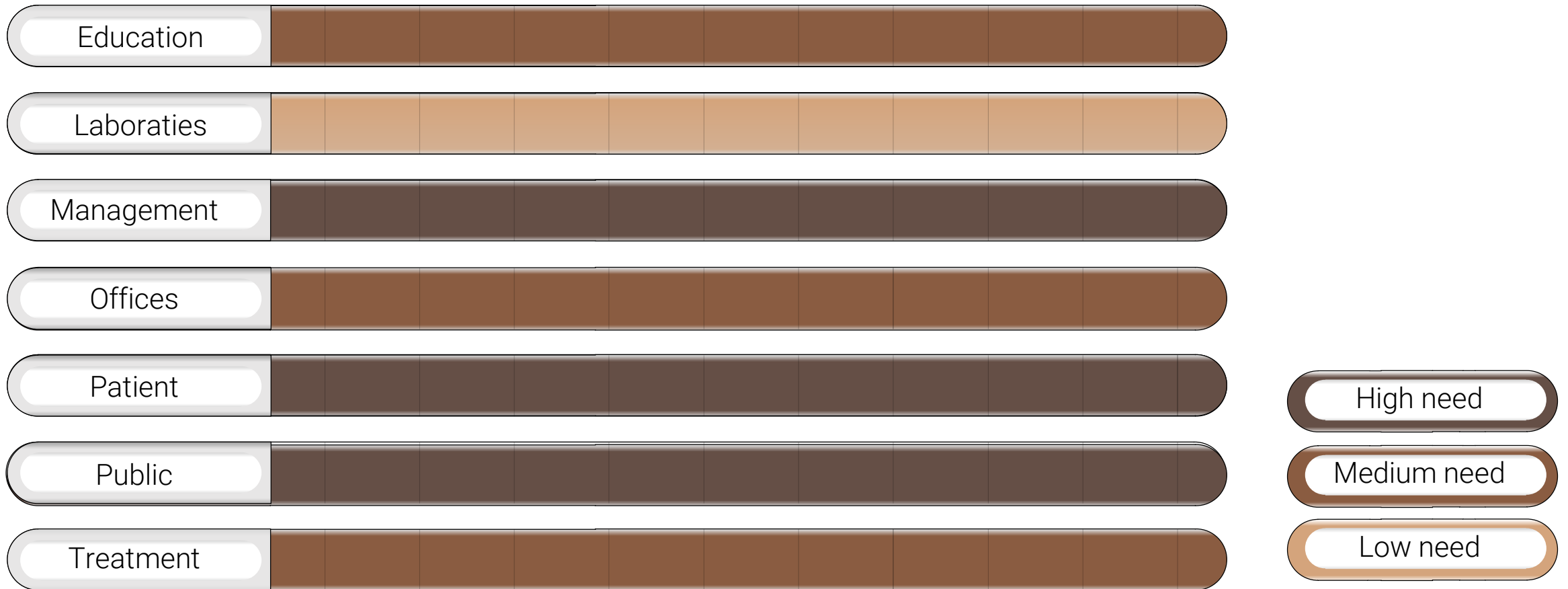

Macro Intervention Strategy

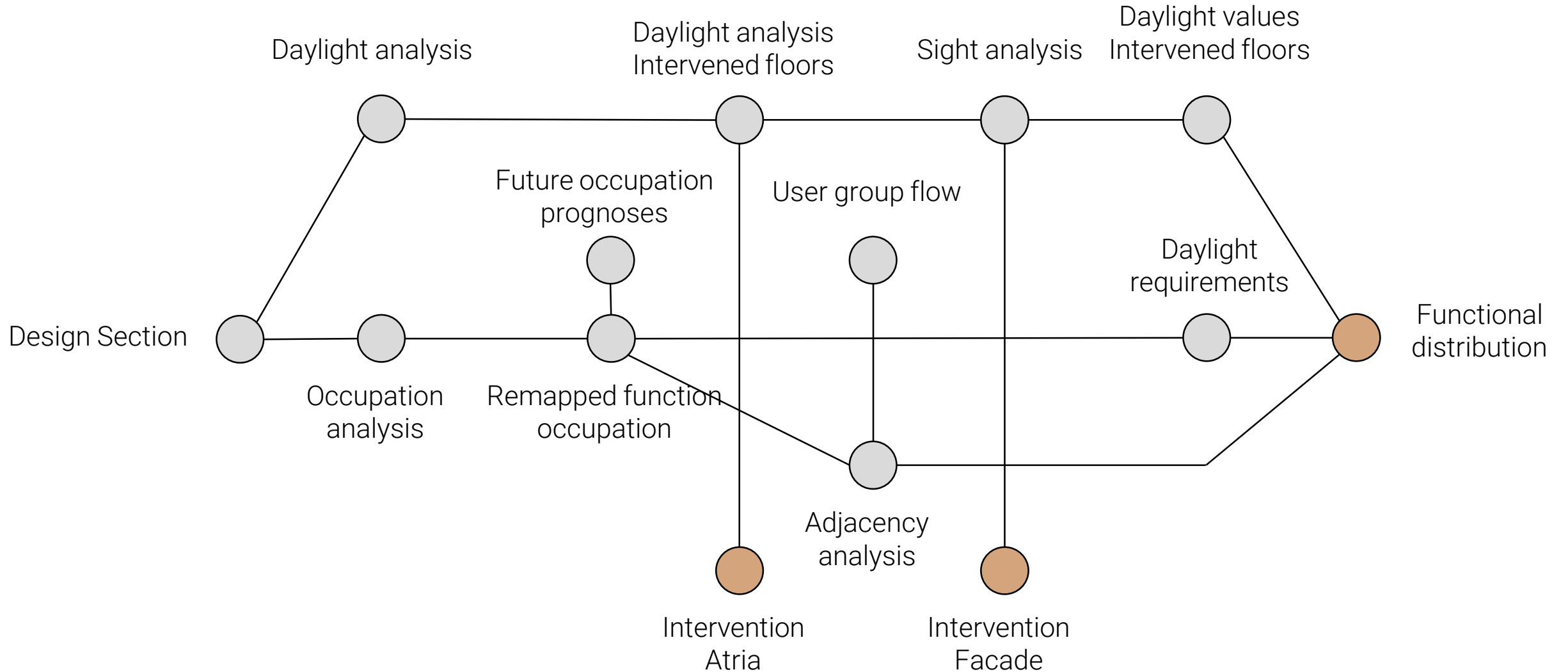

Functional distribution

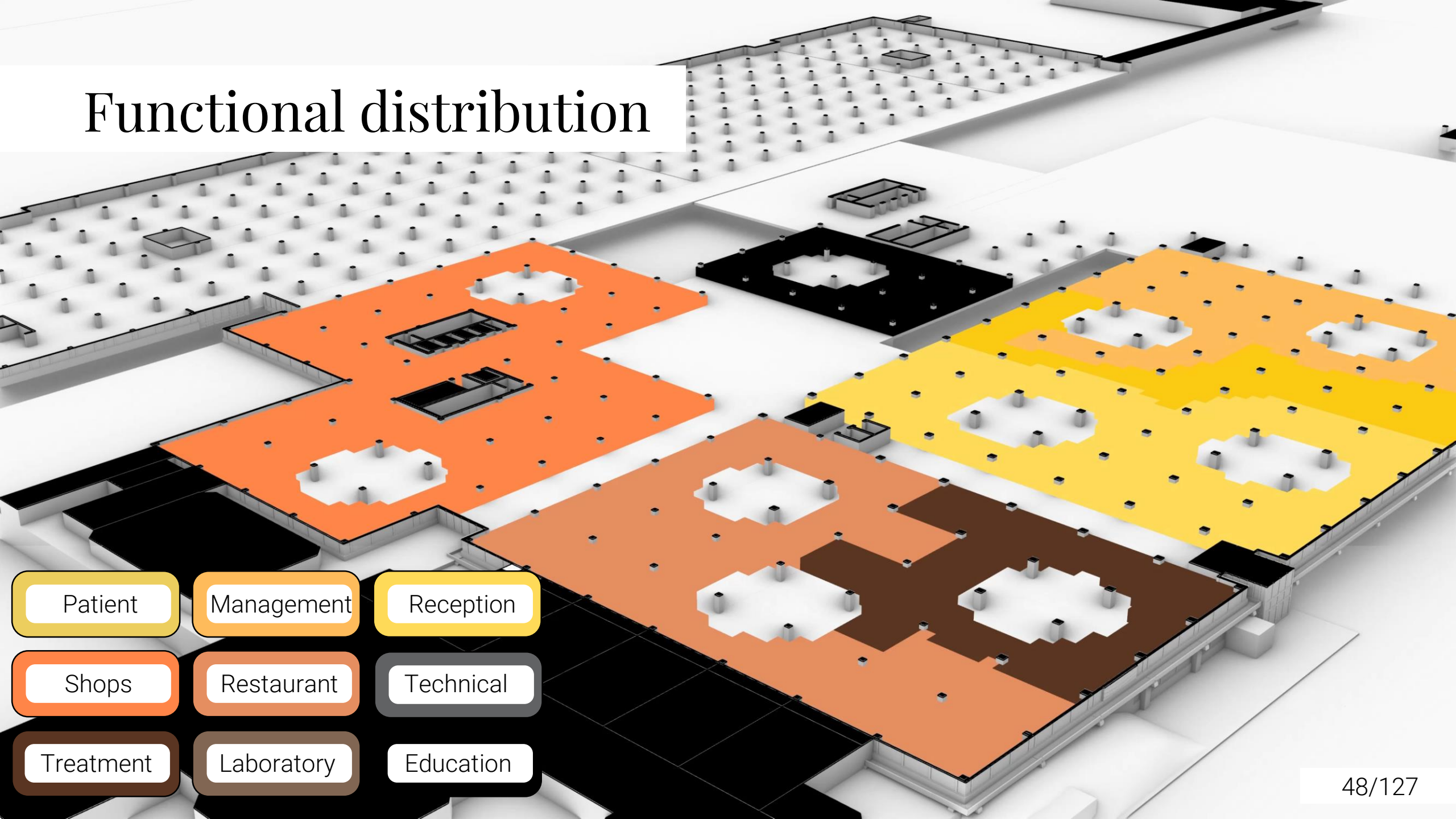

Patient

Management

Reception

Shops

Restaurant

Technical

Treatment

Laboratory

Education

Functional distribution

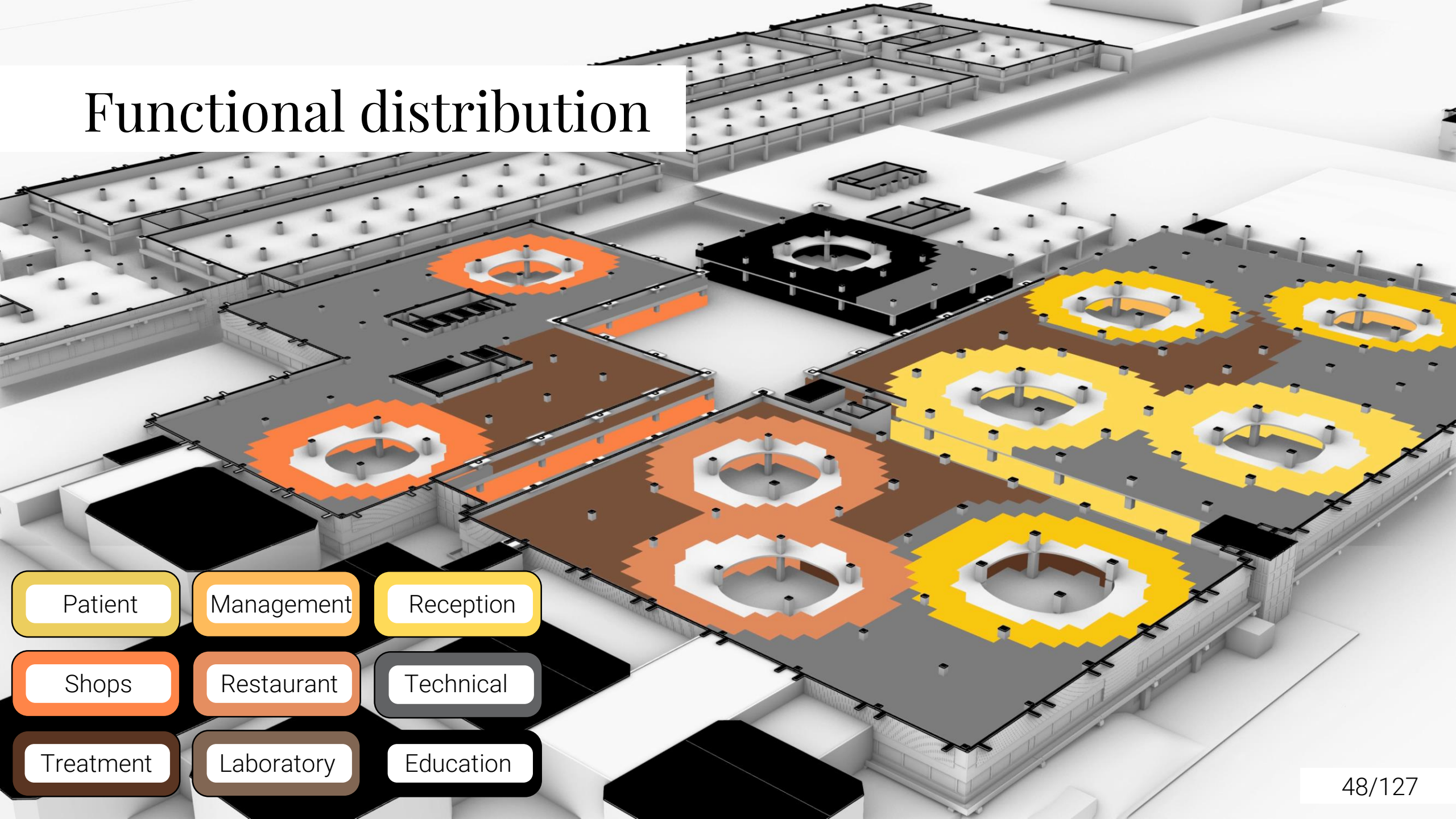

Patient

Management

Reception

Shops

Restaurant

Technical

Treatment

Laboratory

Education

Functional distribution



Patient

Management

Reception

Shops

Restaurant

Technical

Treatment

Laboratory

Education

Functional distribution

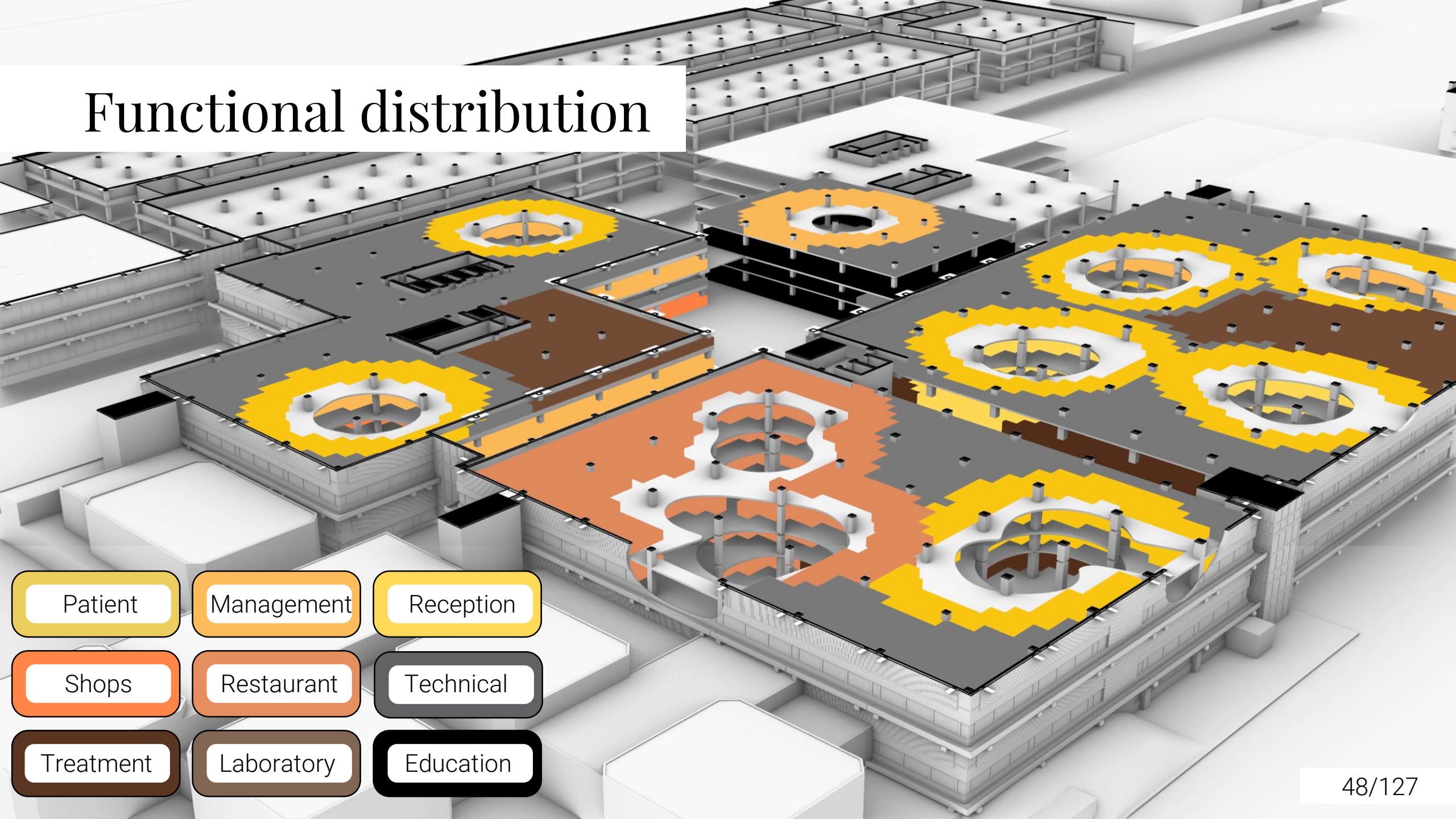

Patient

Management

Reception

Shops

Restaurant

Technical

Treatment

Laboratory

Education

Functional distribution



Patient

Management

Reception

Shops

Restaurant

Technical

Treatment

Laboratory

Education

Functional distribution

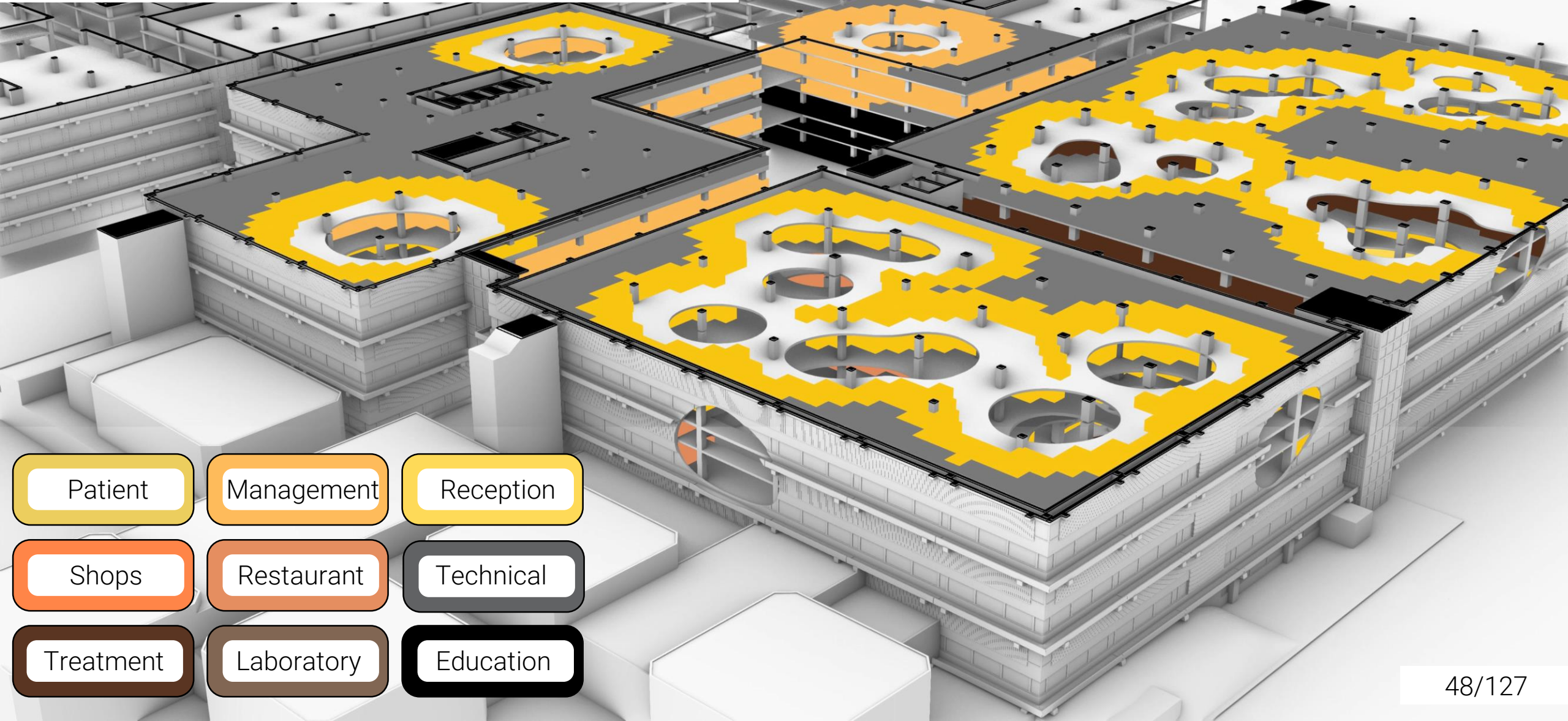

Patient

Management

Reception

Shops

Restaurant

Technical

Treatment

Laboratory

Education

Functional distribution



Patient

Management

Reception

Shops

Restaurant

Technical

Treatment

Laboratory

Education

Functional distribution



Patient

Management

Reception

Shops

Restaurant

Technical

Treatment

Laboratory

Education

Functional distribution



Patient

Management

Reception

Shops

Restaurant

Technical

Treatment

Laboratory

Education

Functional distribution



Patient

Management

Reception

Shops

Restaurant

Technical

Treatment

Laboratory

Education

Functional distribution



Patient

Management

Reception

Shops

Restaurant

Technical

Treatment

Laboratory

Education

Functional distribution



Patient

Management

Reception

Shops

Restaurant

Technical

Treatment

Laboratory

Education

Functional distribution



Patient

Management

Reception

Shops

Restaurant

Technical

Treatment

Laboratory

Education



UvA
Universiteit van Amsterdam

The Meso Scale

The medium scale strategy

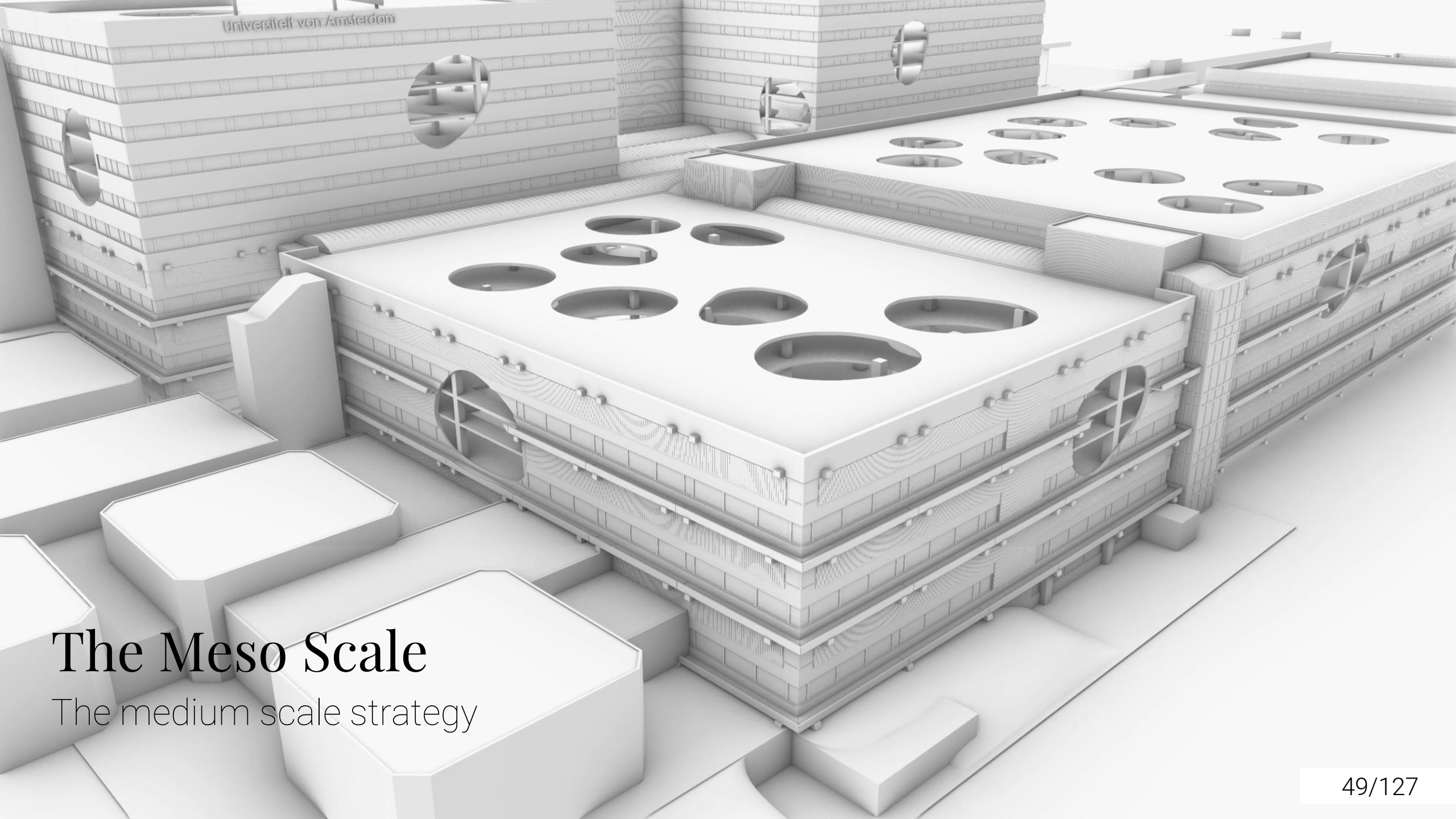

Universiteit van Amsterdam

The Meso Scale

The medium scale strategy

Atria volumes

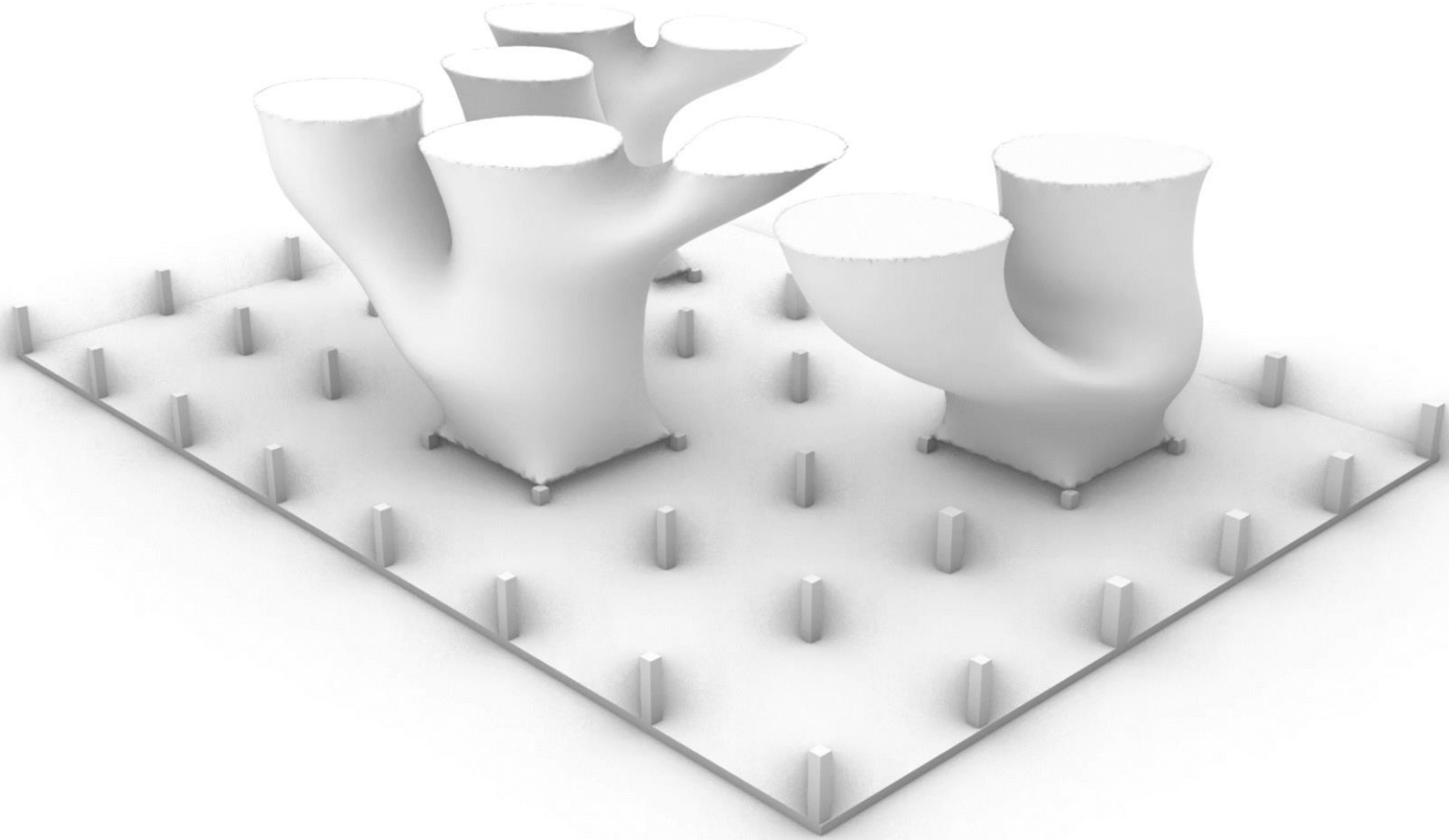

Atria volumes

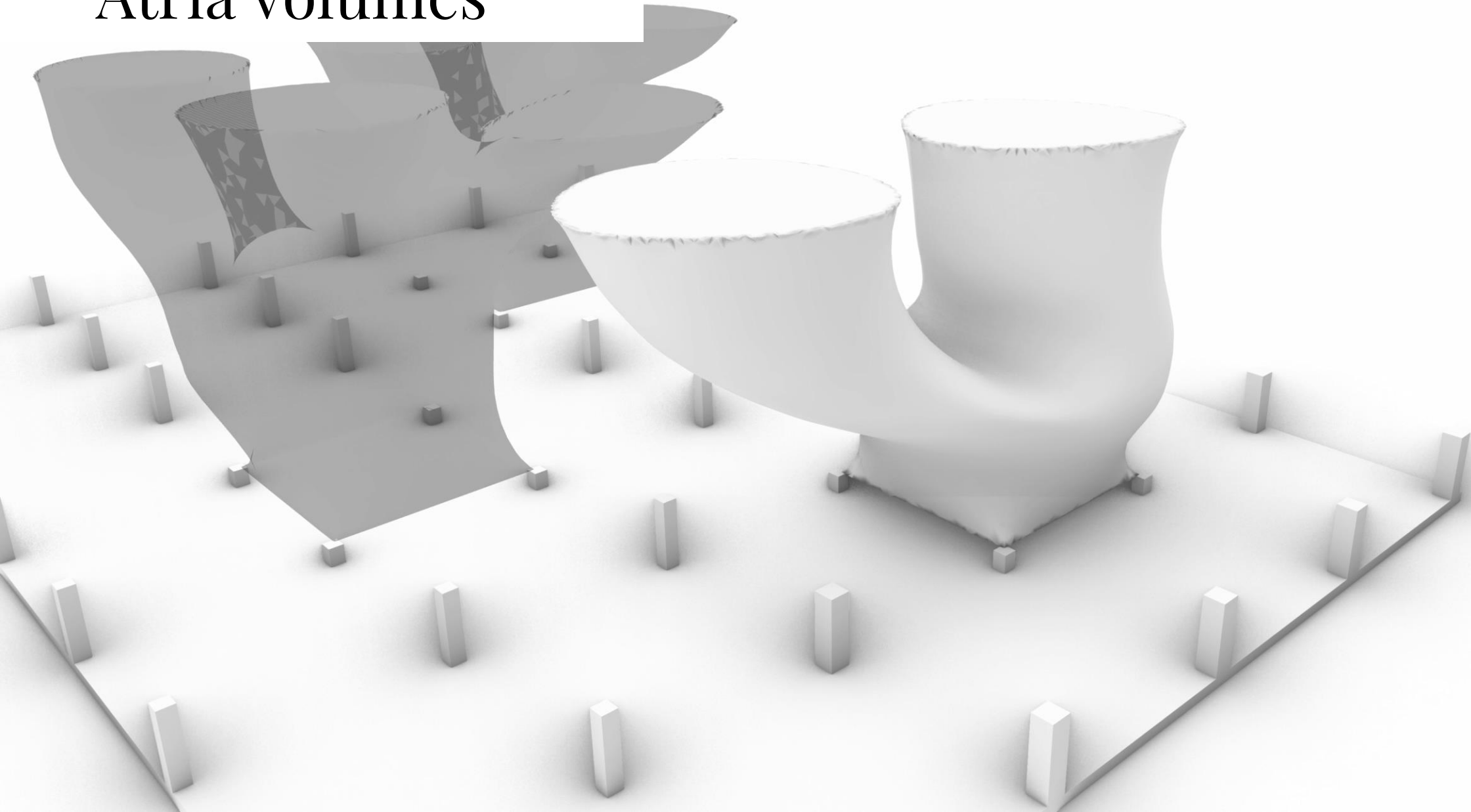

Structural analysis

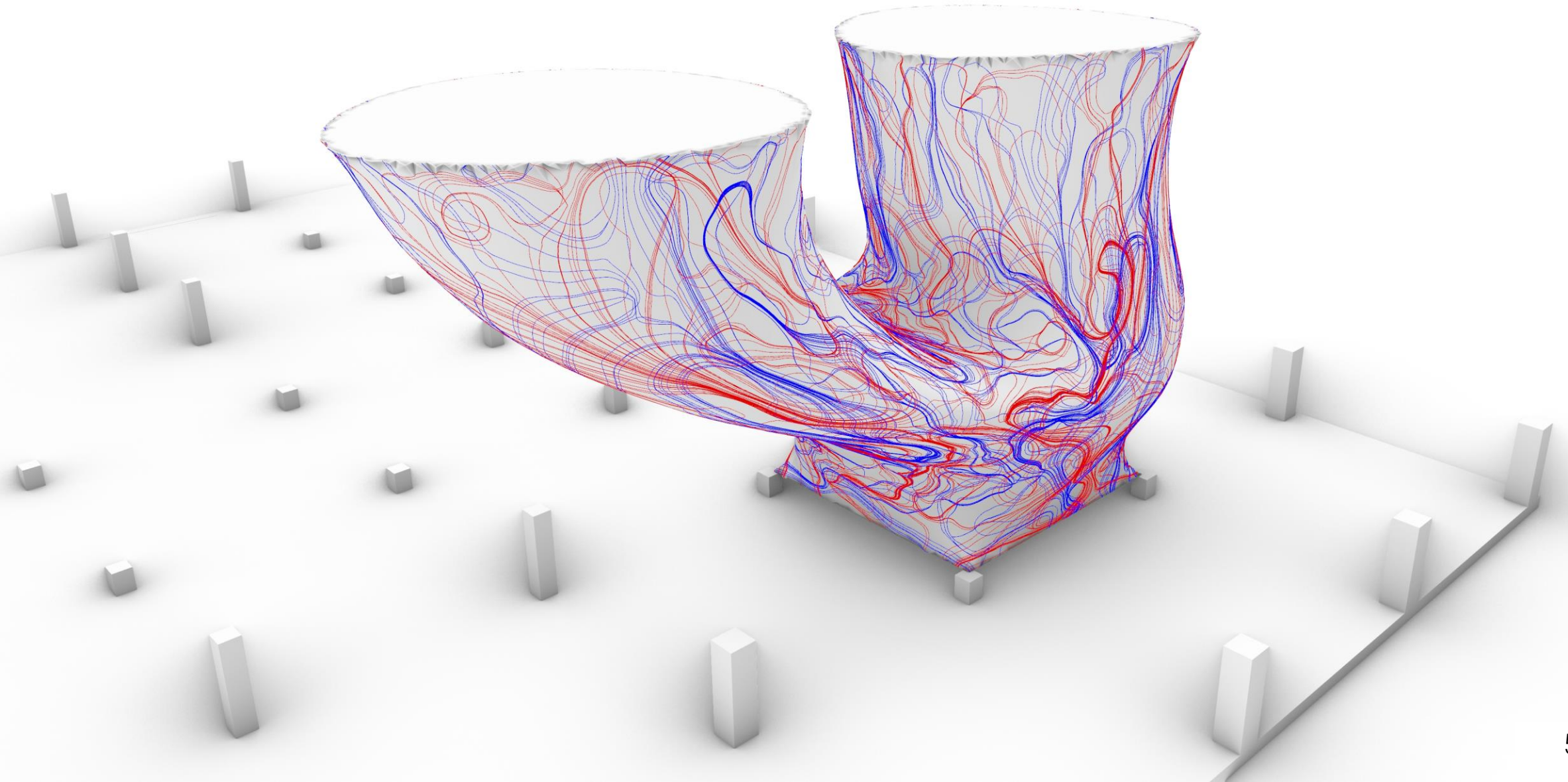

Column creation

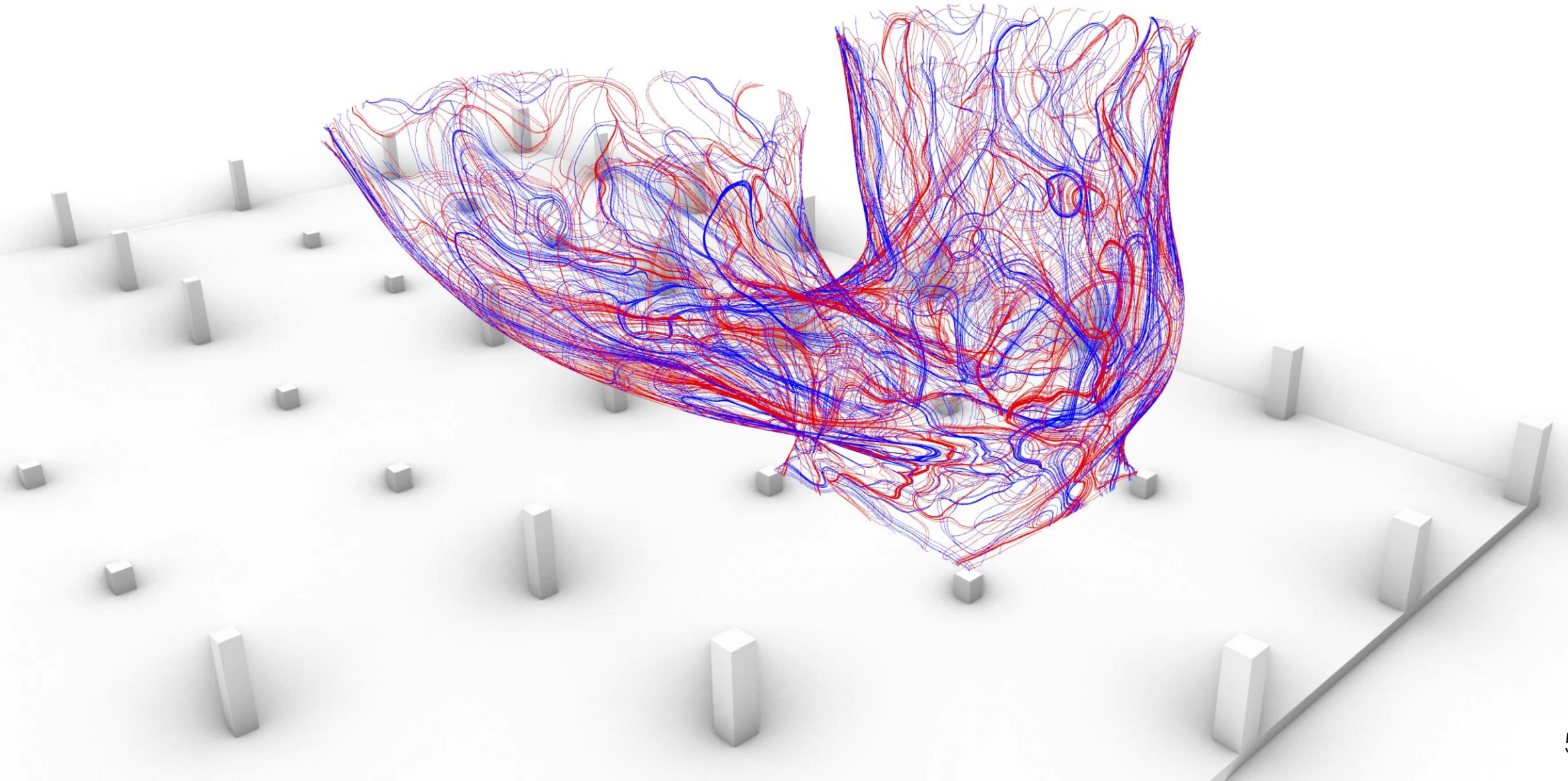

Column creation

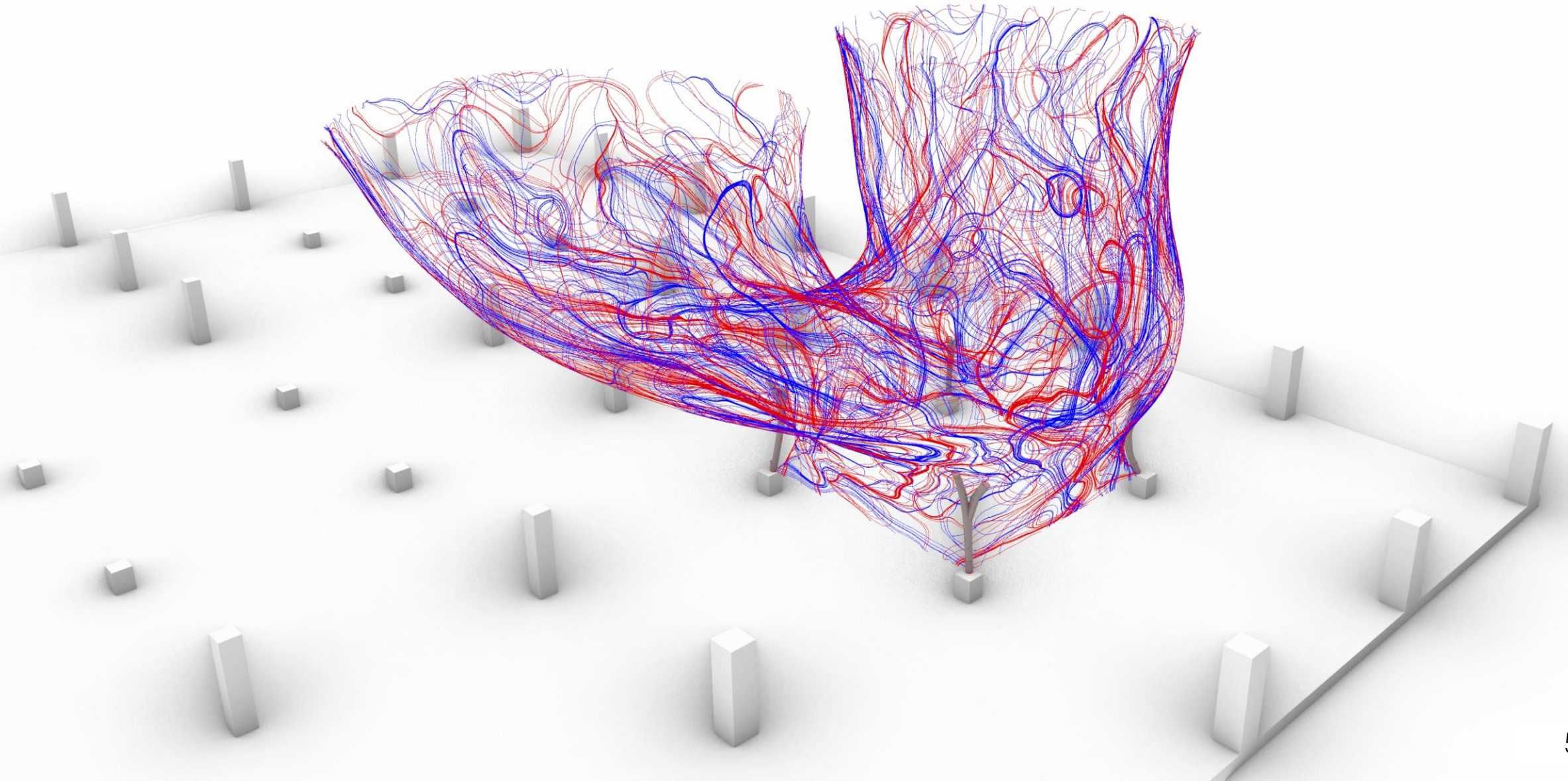

Column creation

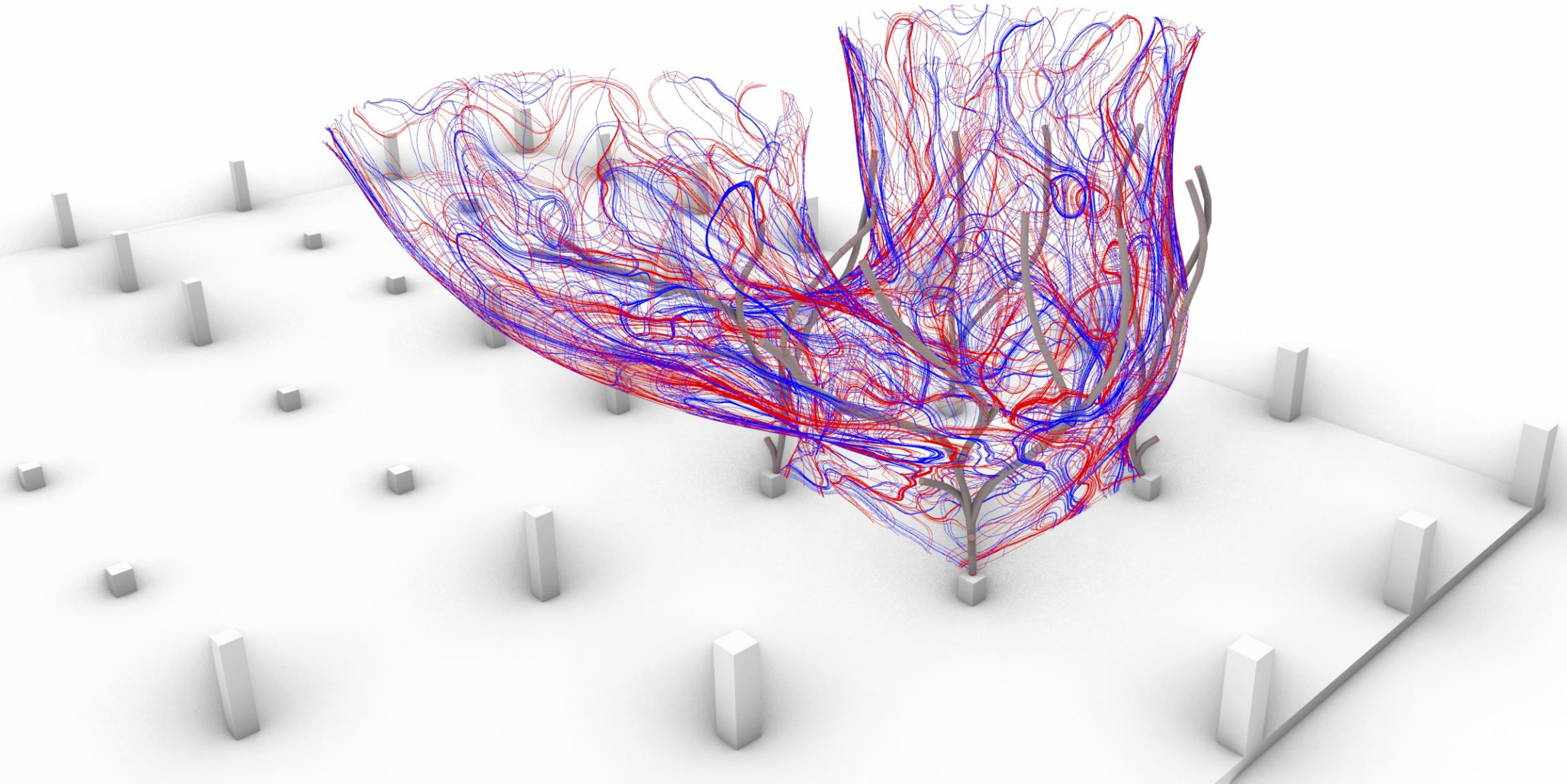

Column creation

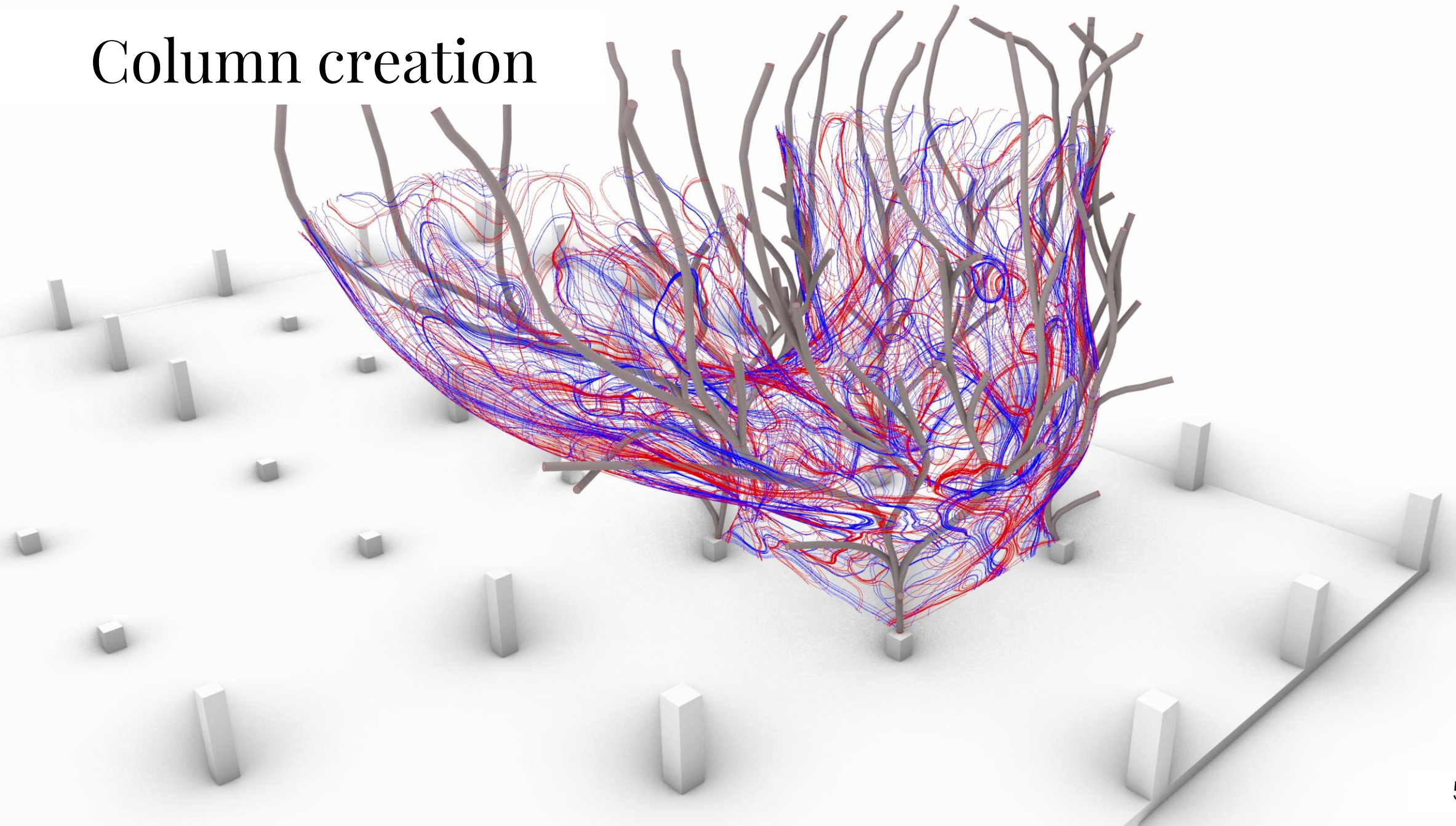

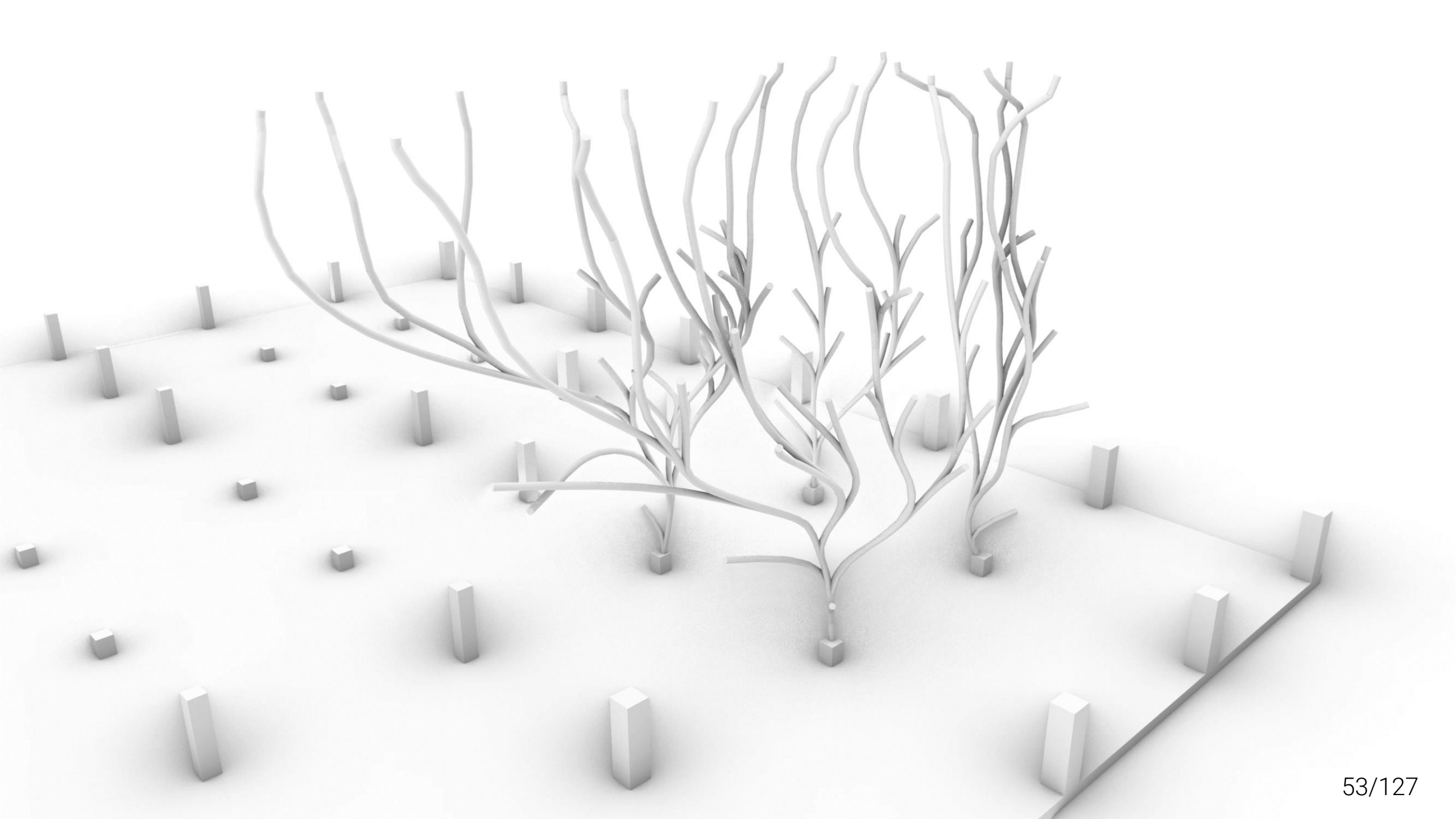

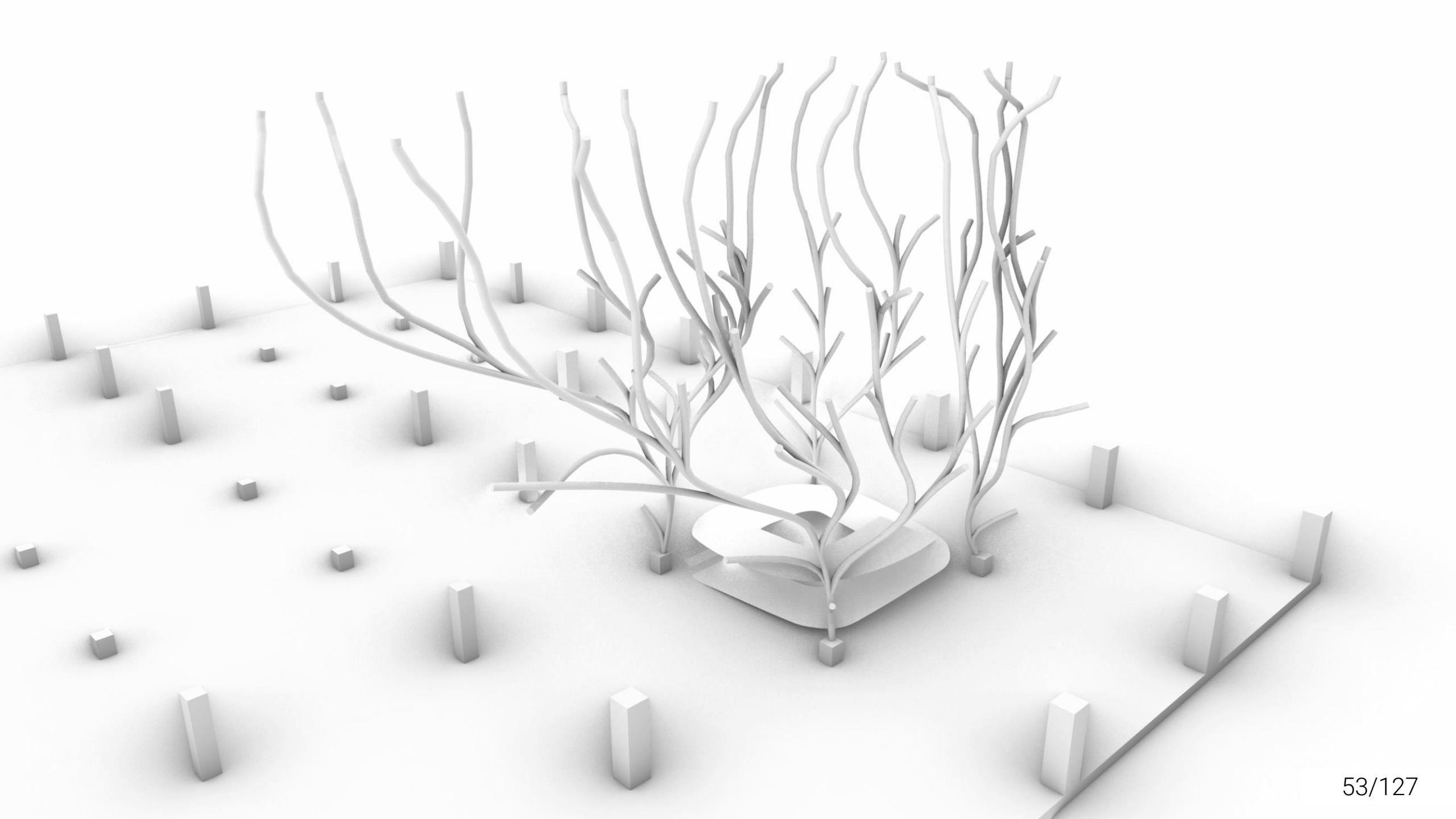

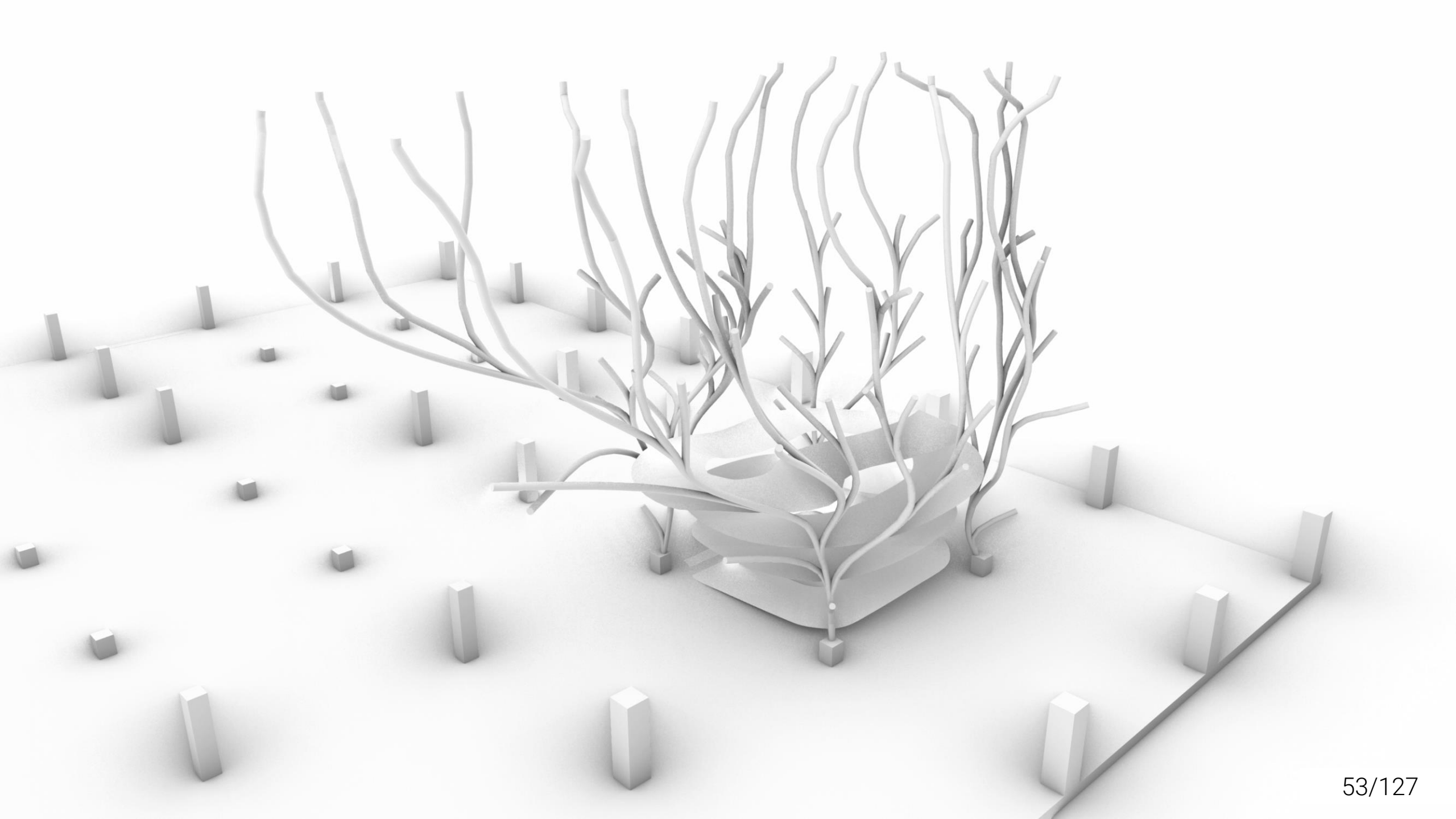

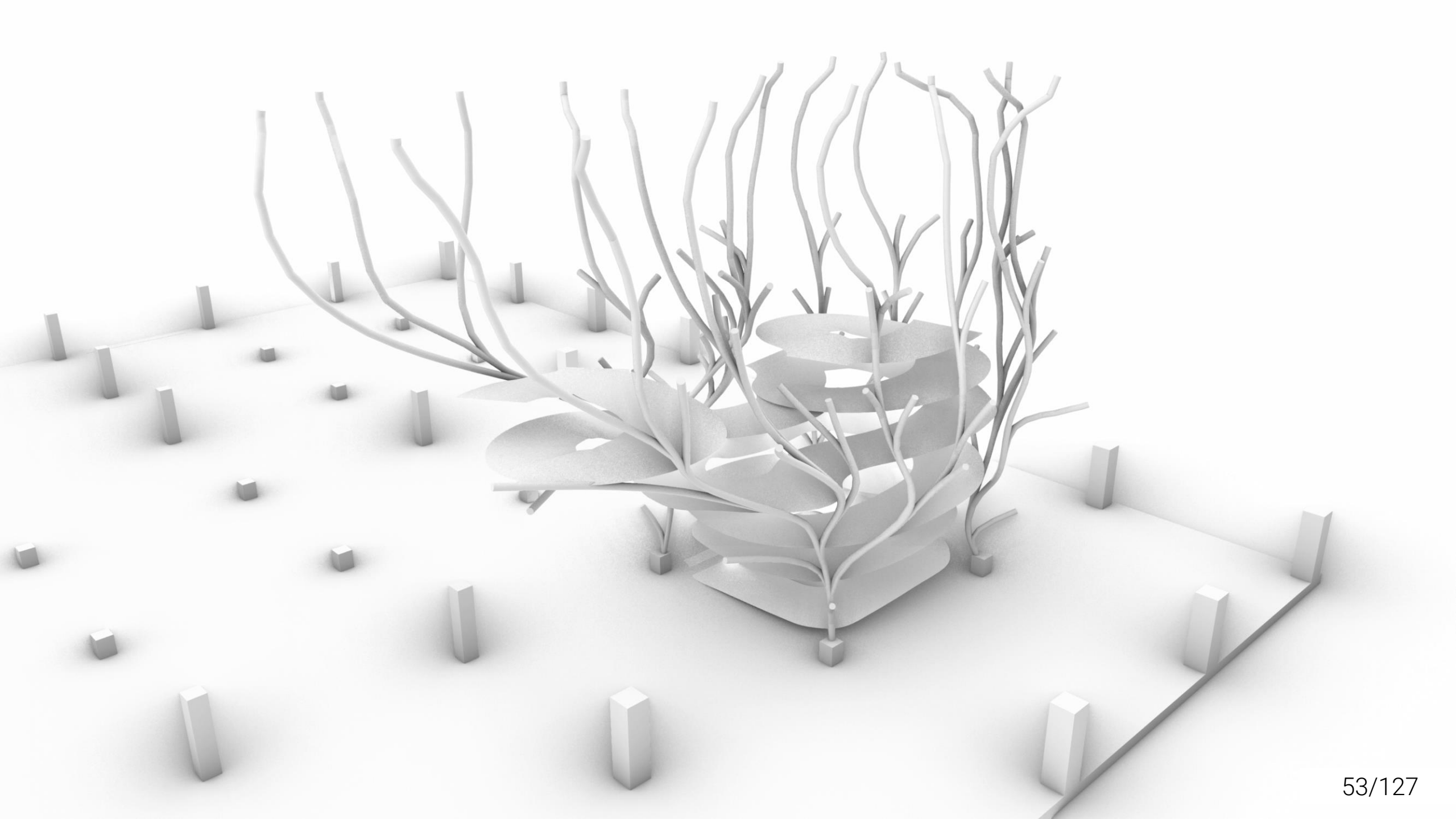

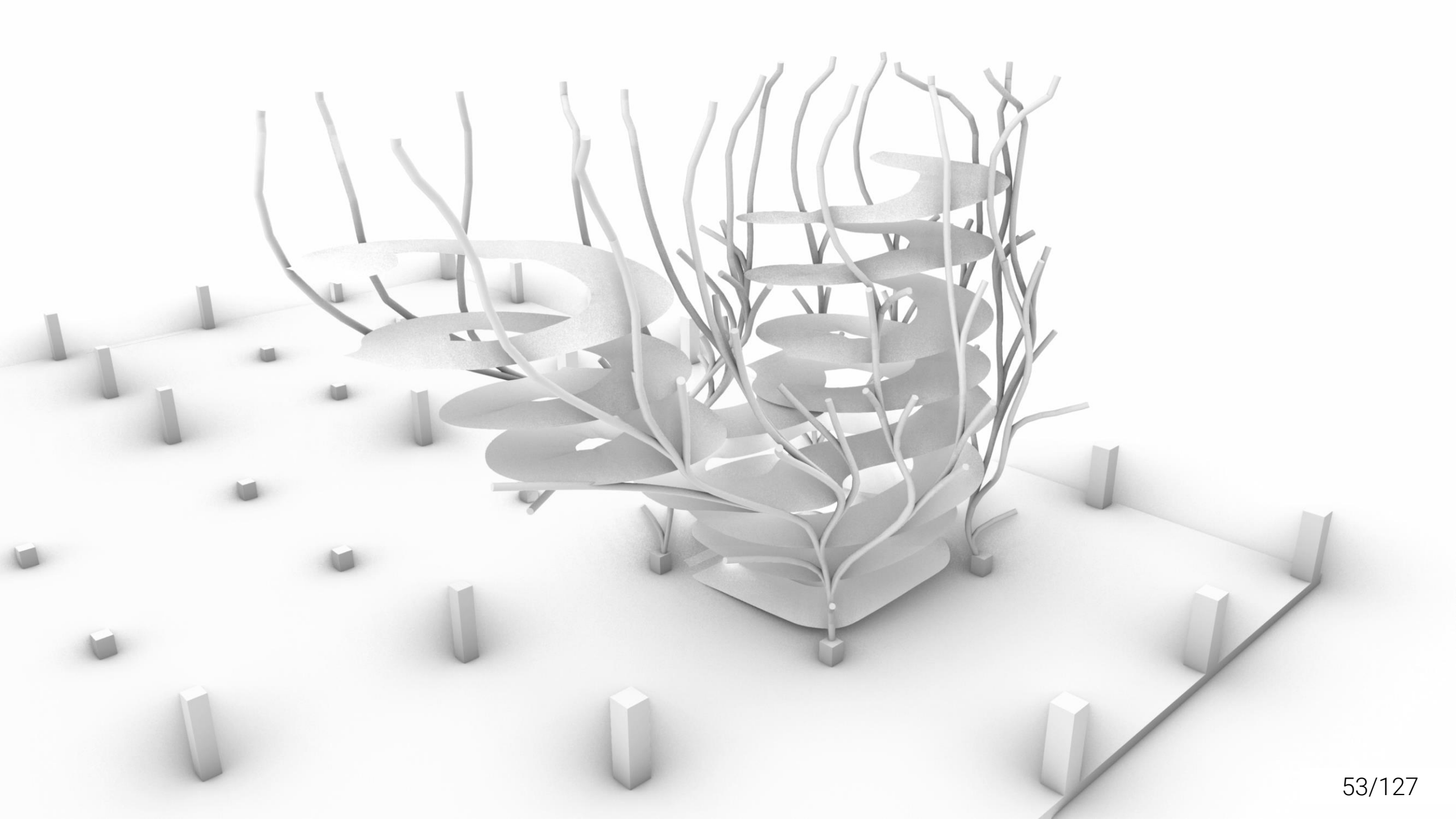

Ramp width

(Movement upwards + Movement downwards) / n-Ramps floor

Mapped to domain 1200mm and 2500mm

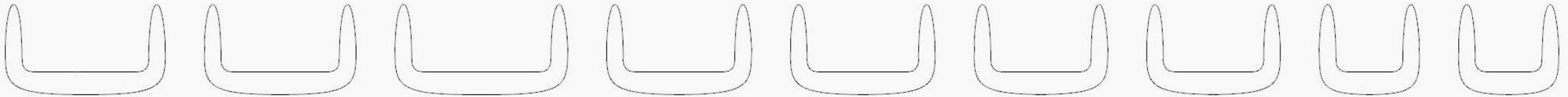

00-01
2275 mm

01-02
2125 mm

02-03
2500 mm

03-04 01
2000 mm

03-04 02
2000 mm

04-05 01
1800 mm

04-05 02
1800 mm

05-06 01
1200 mm

05-06 02
1200 mm

Ramp structure

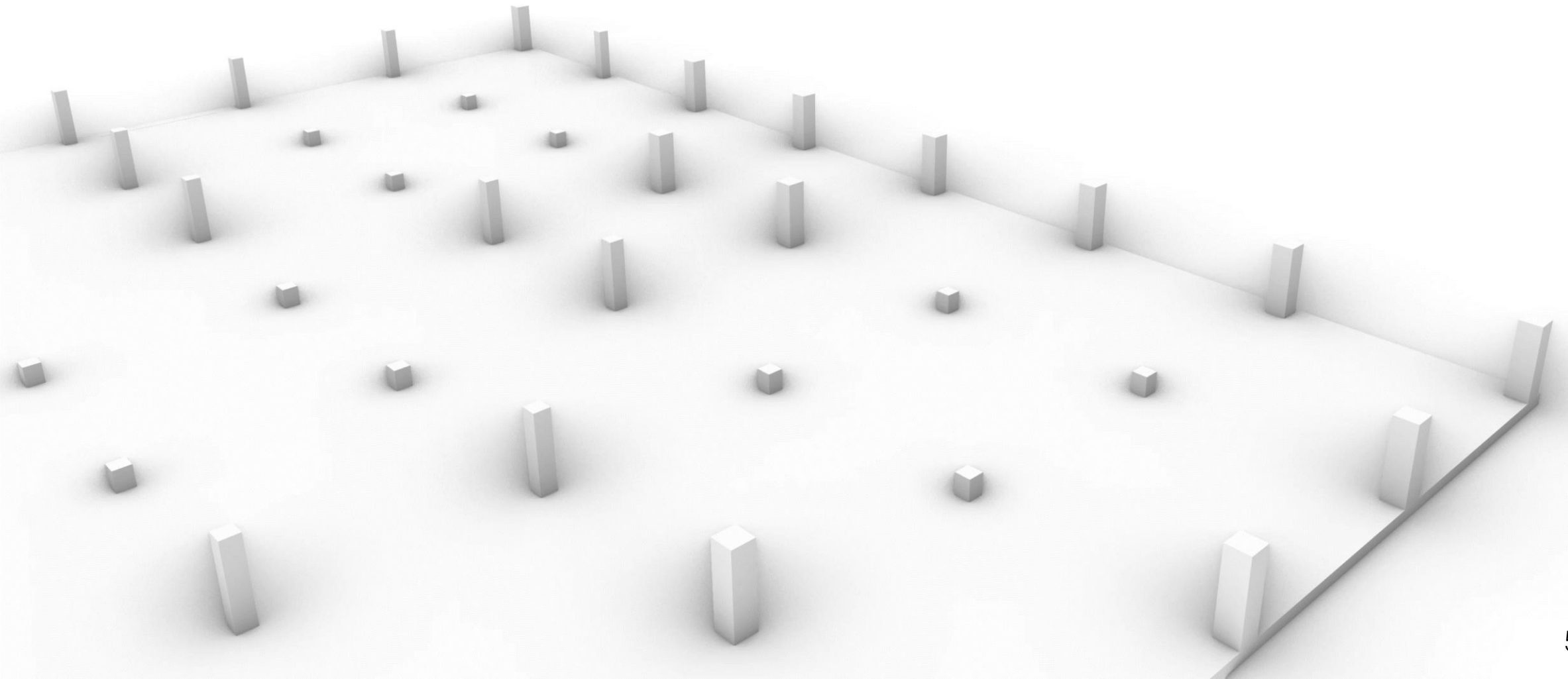

Ramp structure

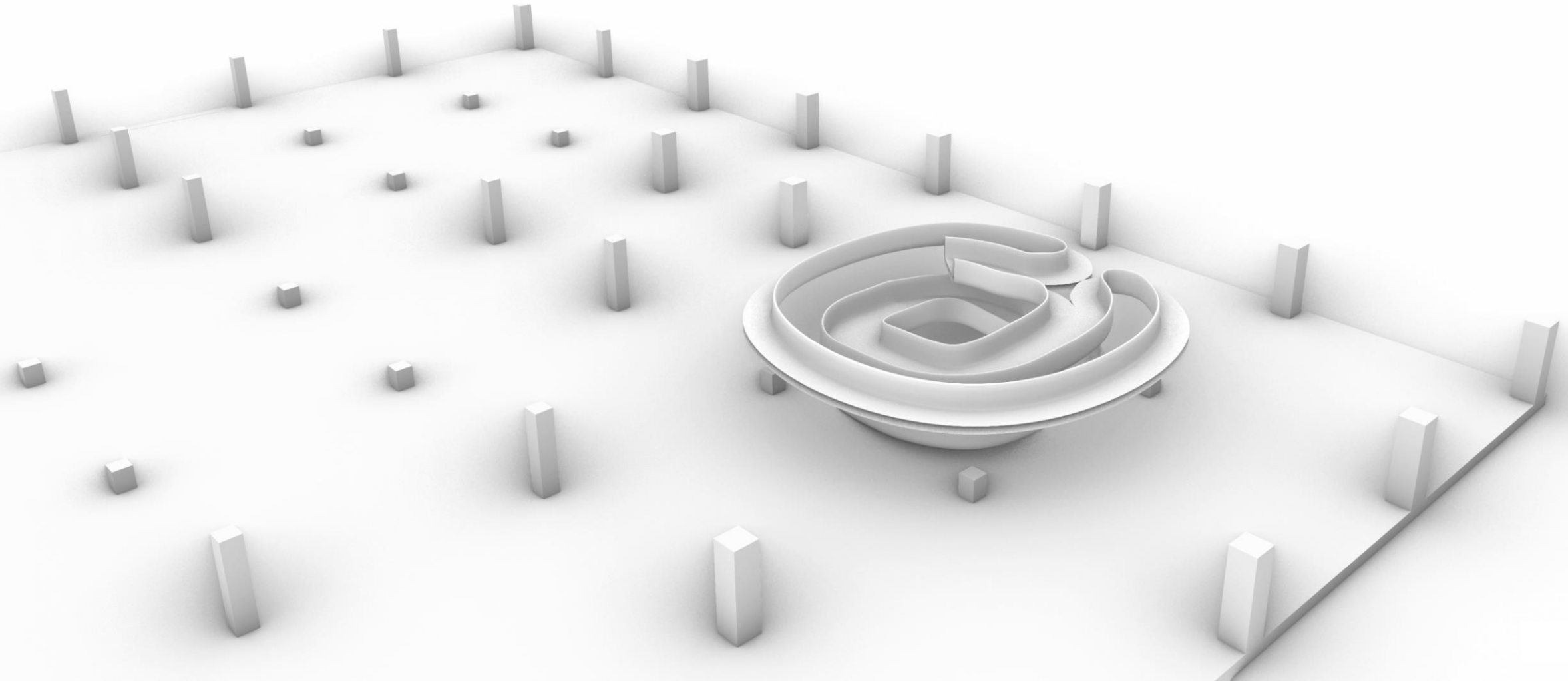

Ramp structure



Ramp structure

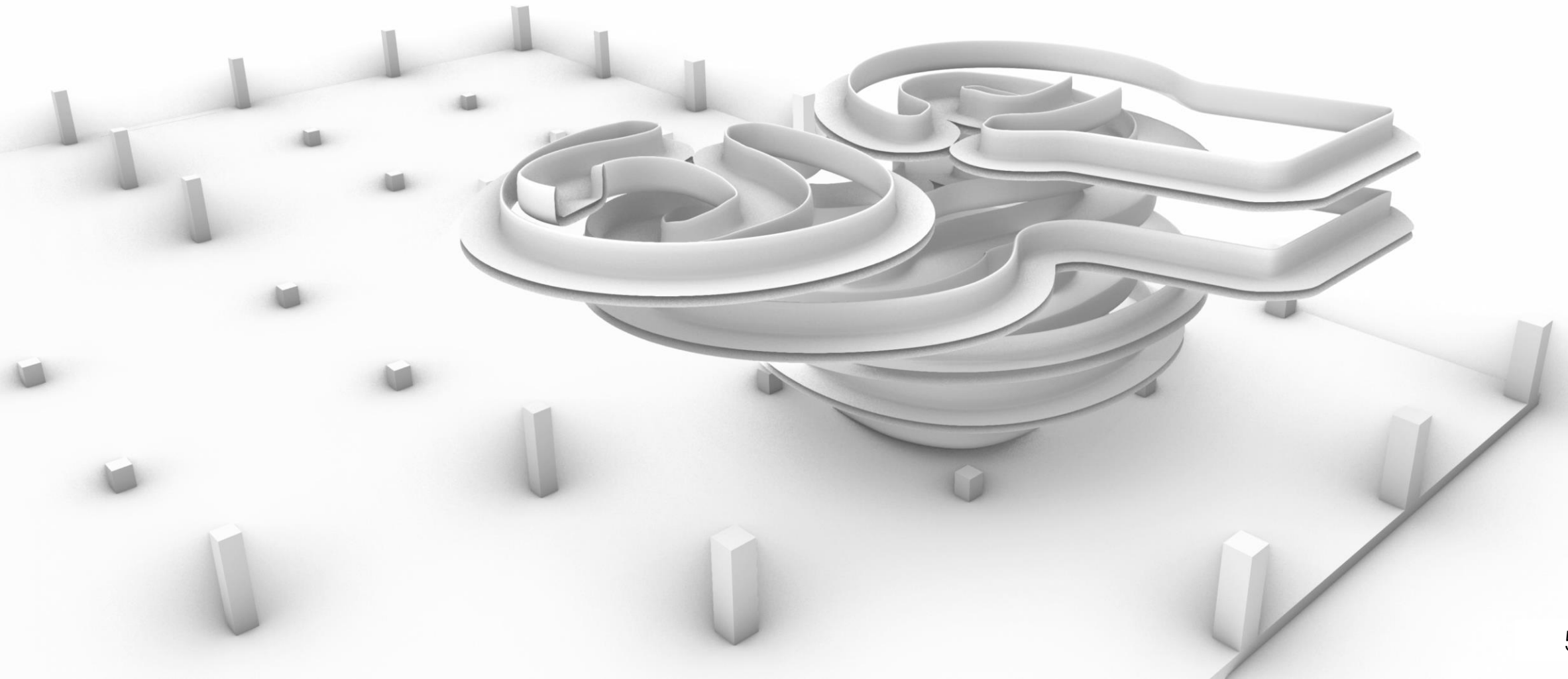

Ramp structure

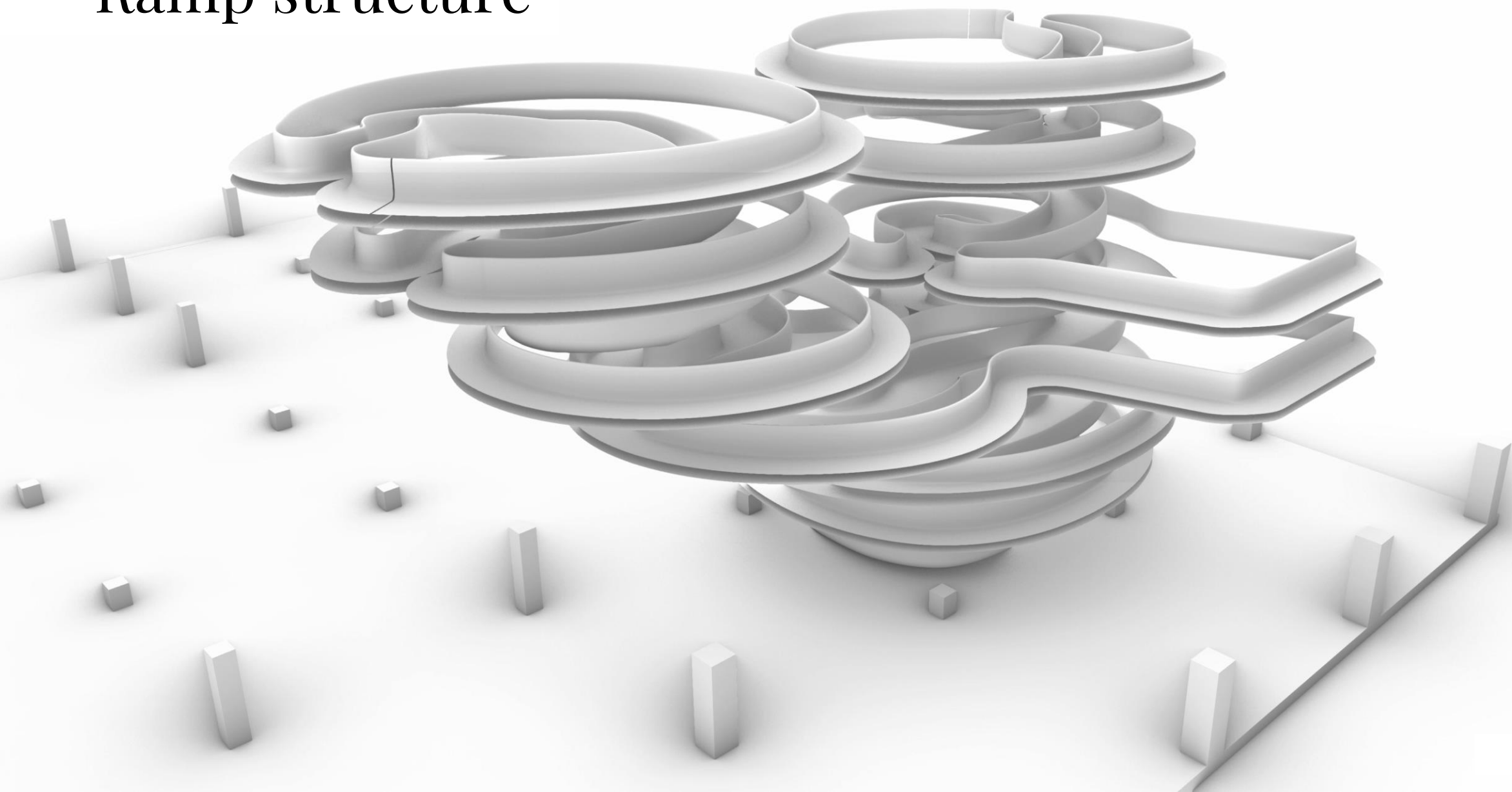

Ramp sections

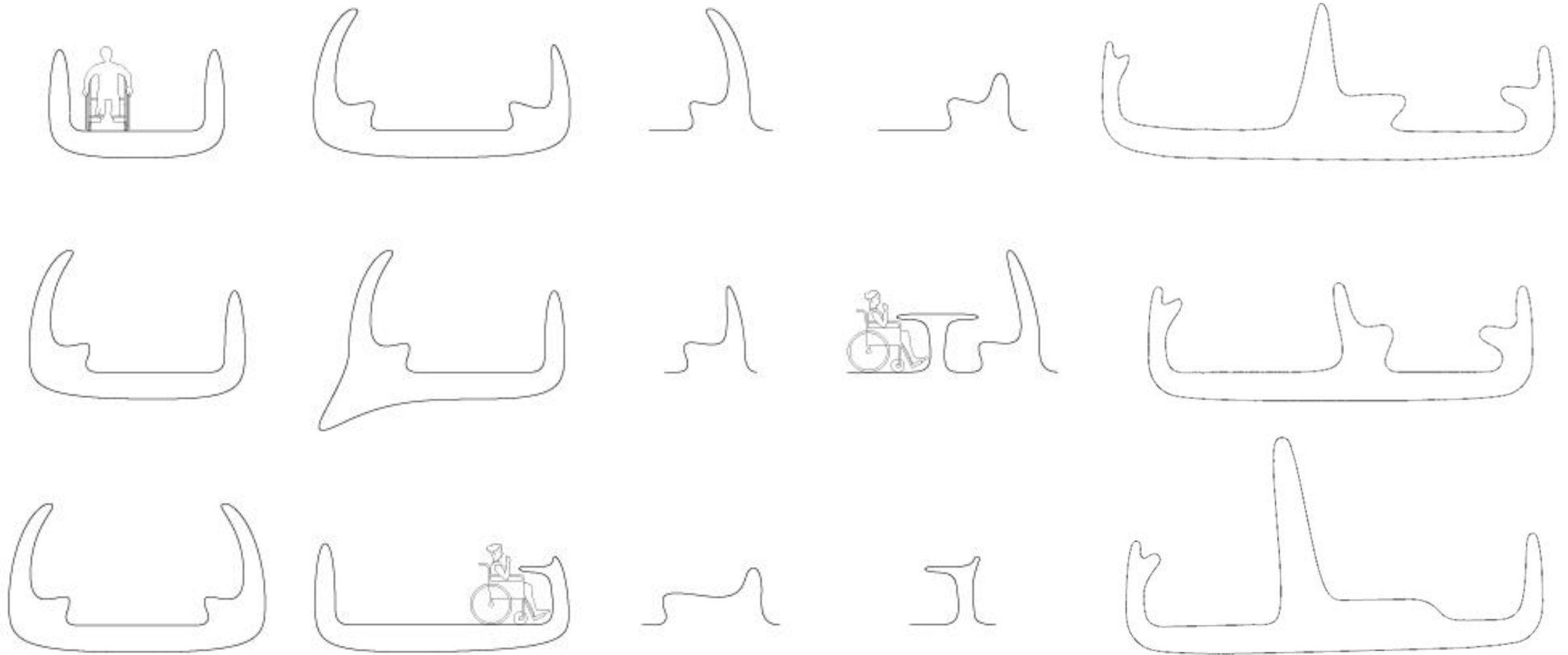

Ramp sections

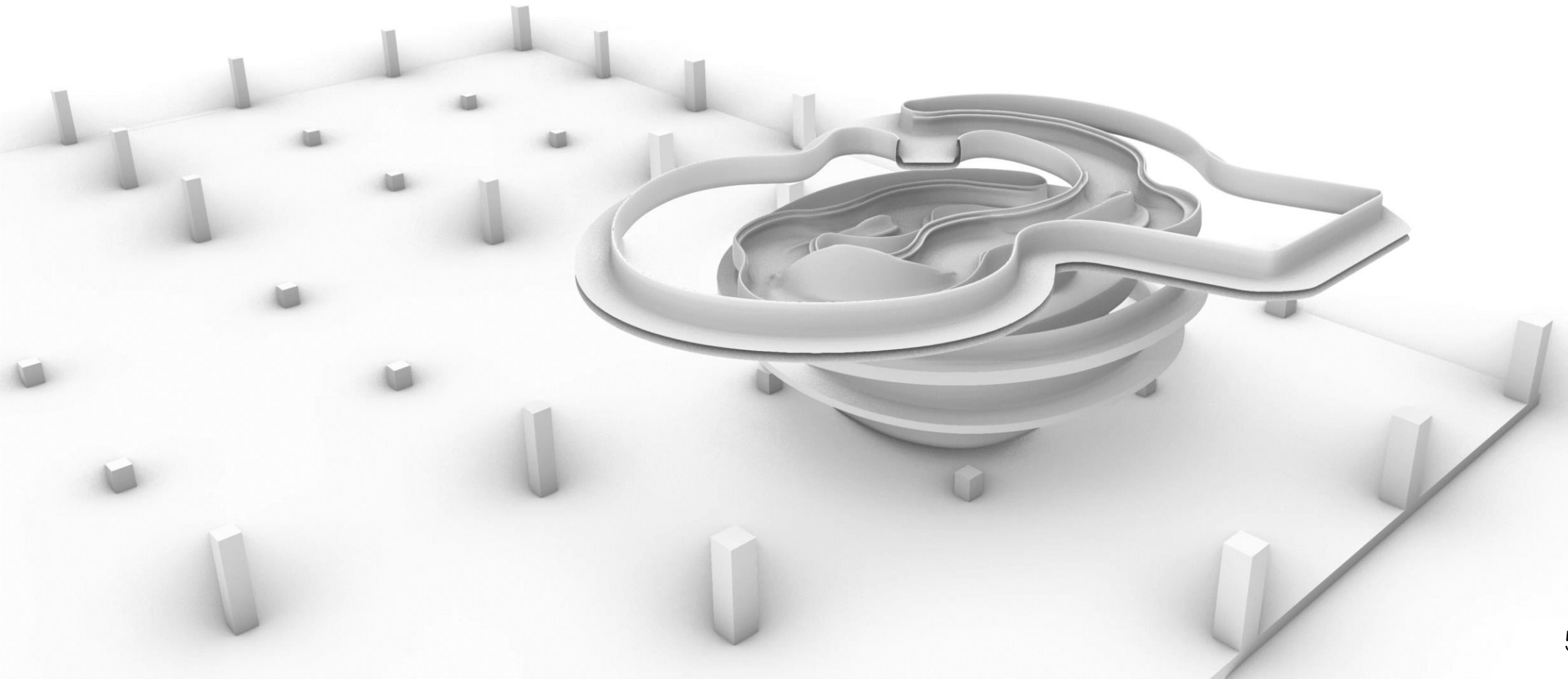

Ramp sections



Floor support structure

A 3D architectural rendering of a floor support structure. The scene features a white floor with several vertical rectangular supports. Two circular platforms, each with a complex, multi-layered, maze-like structure on top, are positioned in the upper left and upper right. A ramp section, also with a complex, multi-layered structure, is located in the lower right. The entire structure is rendered in a light gray color with soft shadows.

Previous iteration ramp sections

Ramp support structure

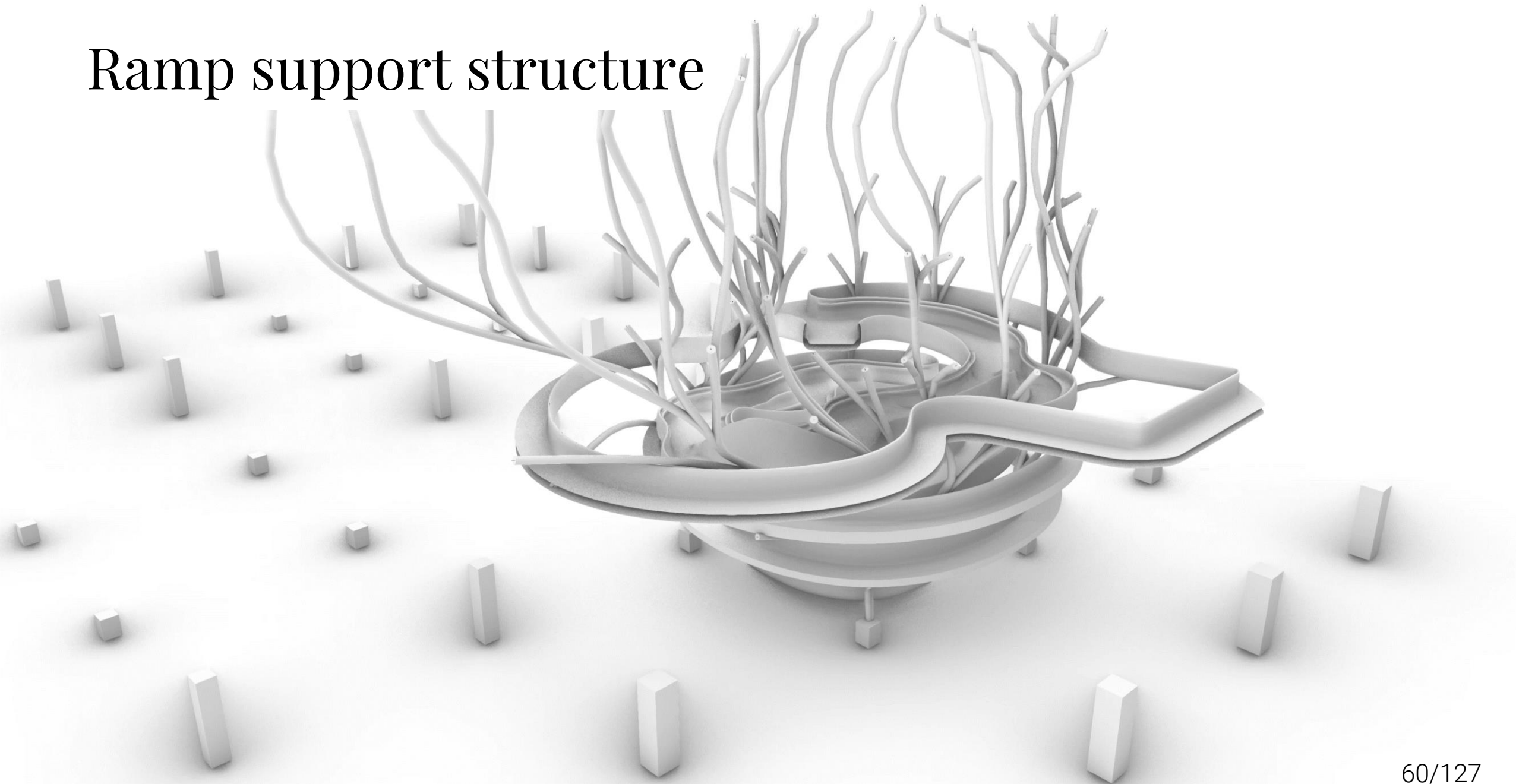

Ramp support structure

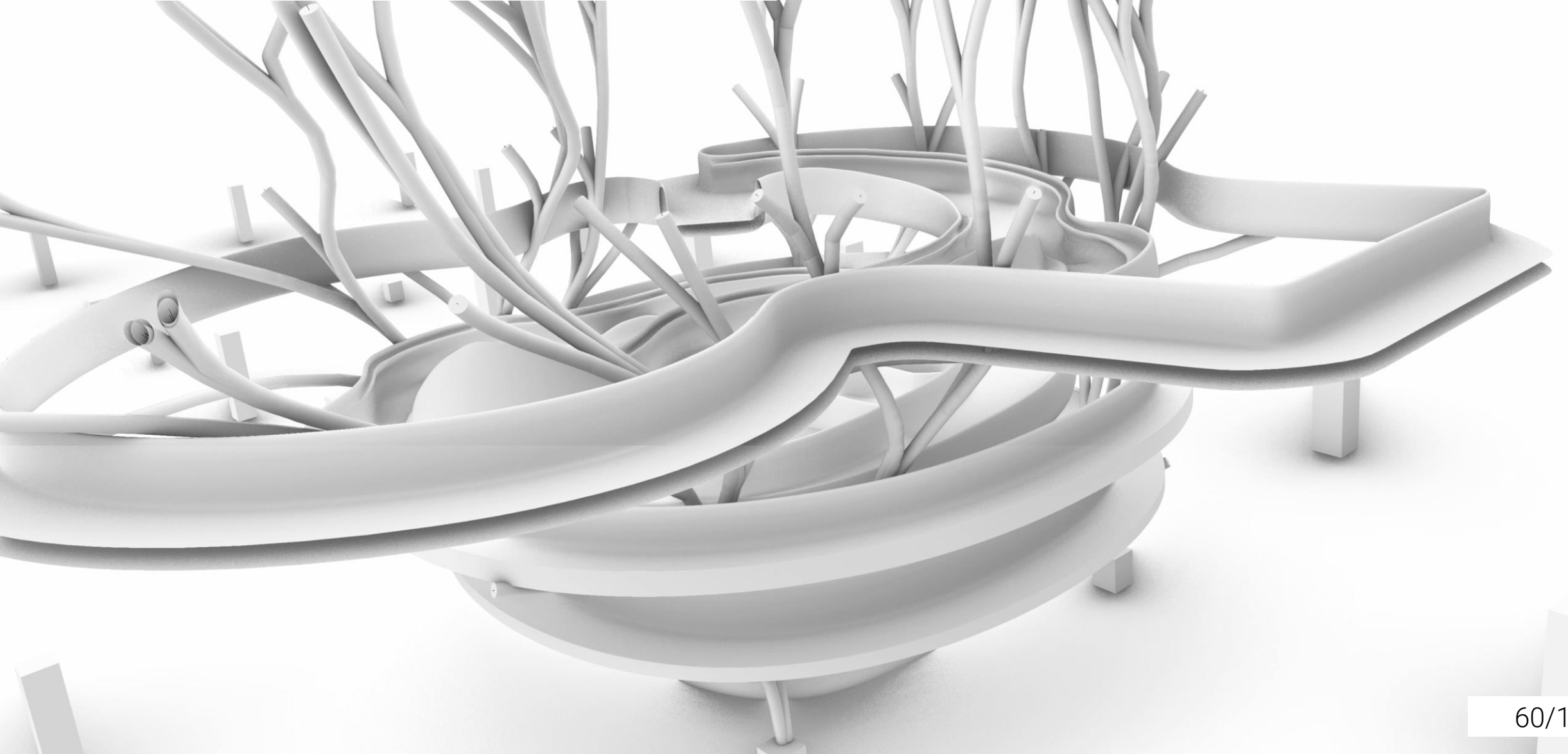

Ramp support structure

A 3D architectural rendering of a ramp support structure. The structure is composed of multiple white, cylindrical columns of varying heights and thicknesses. These columns are arranged in a way that they support a series of horizontal, curved ramp sections. The ramps are also white and have a smooth, rounded appearance. The overall design is clean and modern, with a focus on geometric forms and structural integrity. The background is a plain, light gray, which makes the white structure stand out.

Ramp support structure



Ramp support structure

A 3D architectural rendering of a ramp support structure. The structure is composed of several thick, white, cylindrical columns of varying heights and thicknesses. These columns are interconnected by horizontal and diagonal beams, creating a complex, lattice-like framework. The overall design is clean and modern, with a focus on geometric forms and structural integrity. The background is a plain, light gray, which emphasizes the white structure.

Ramp support structure

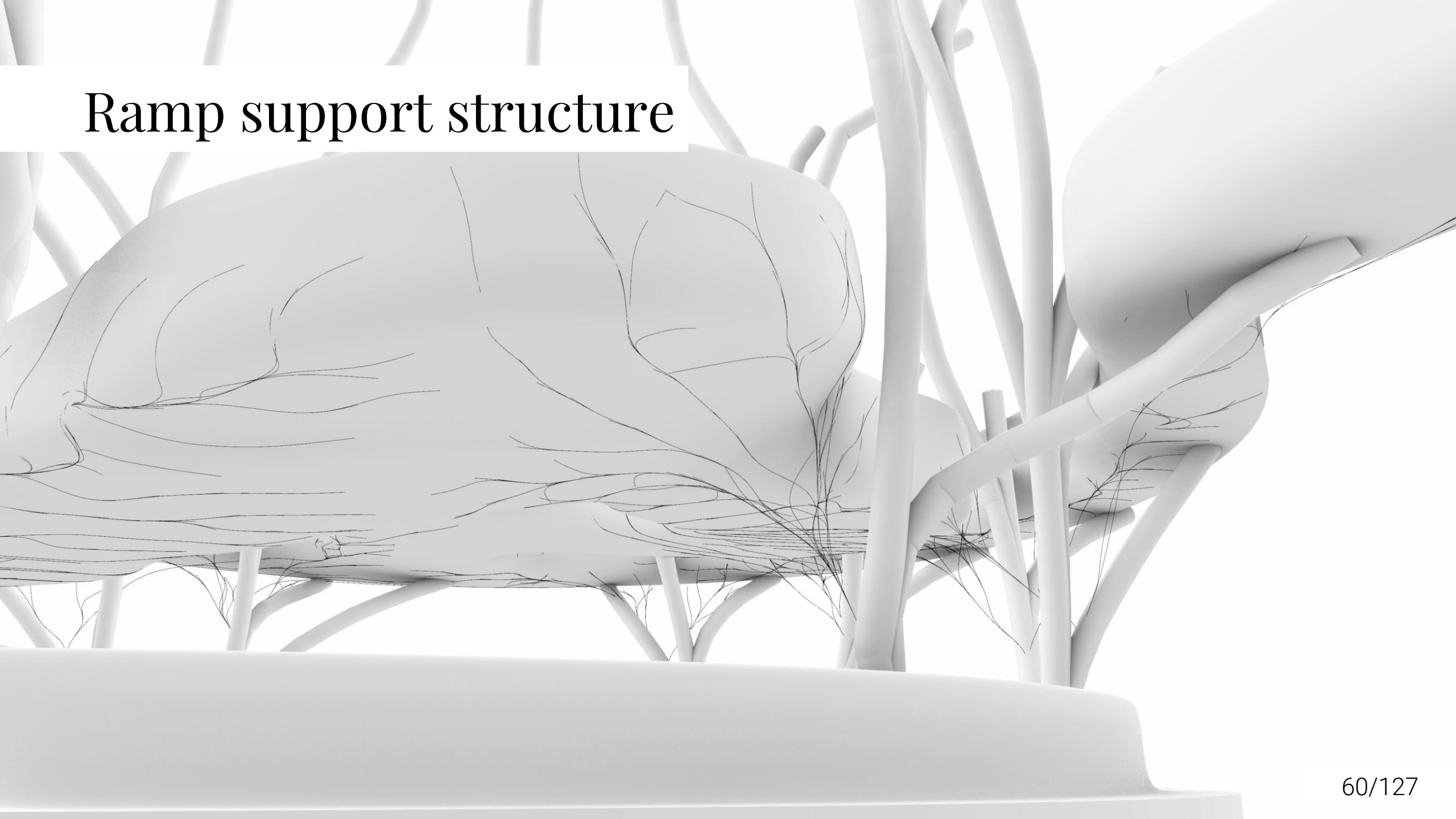

Ramp support structure

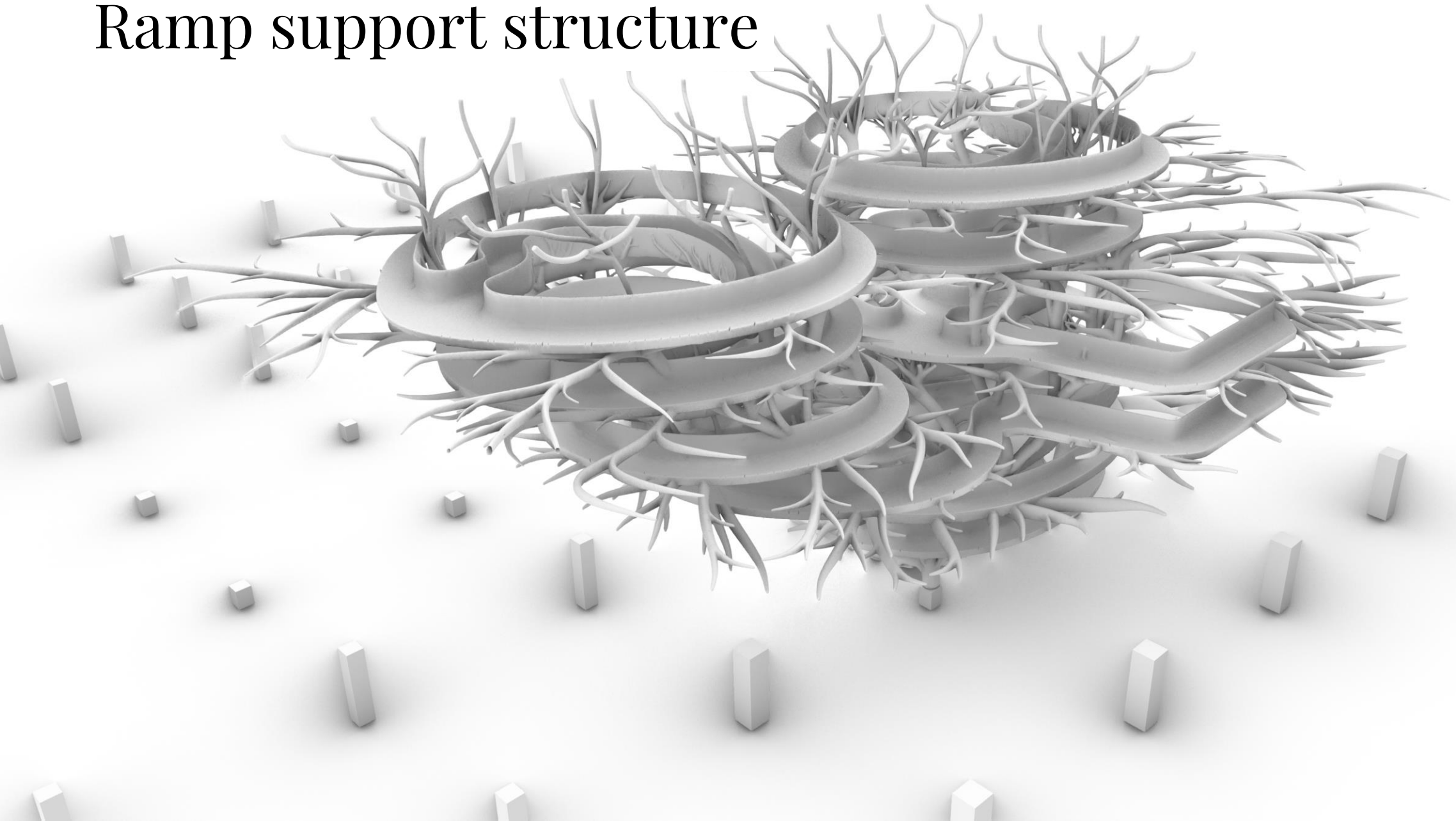

Structural reference

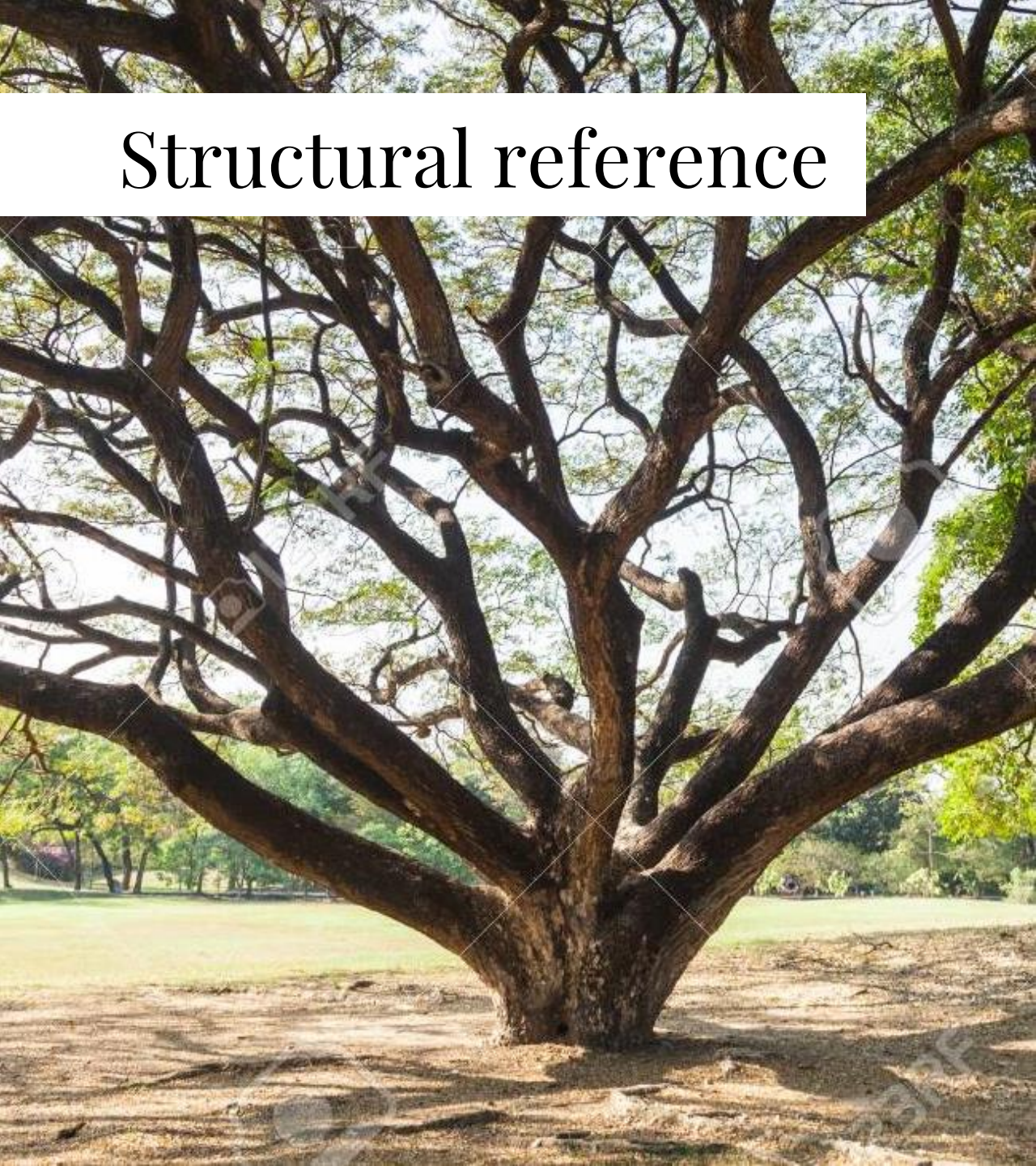

Pull strategy

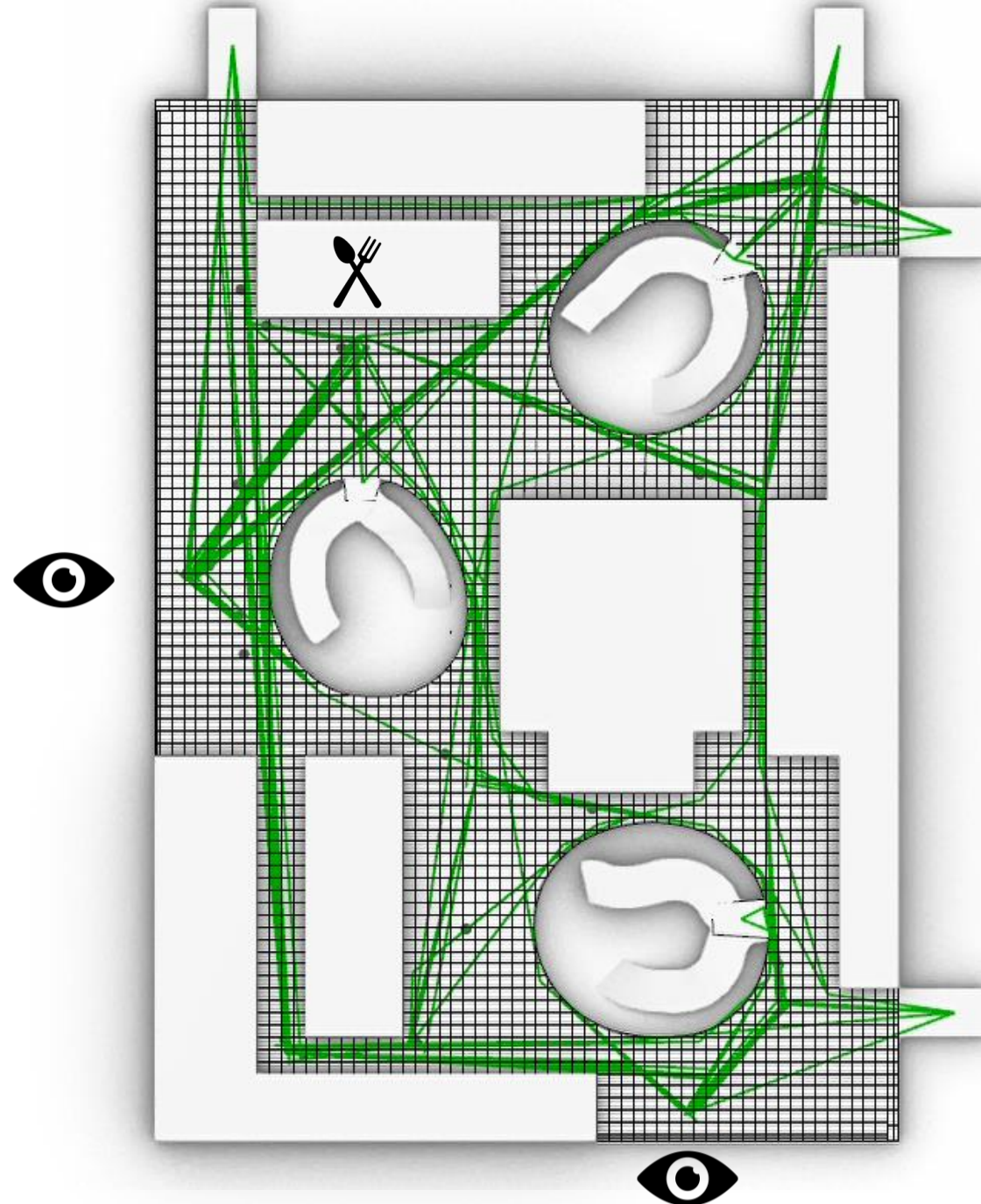

Pull strategy

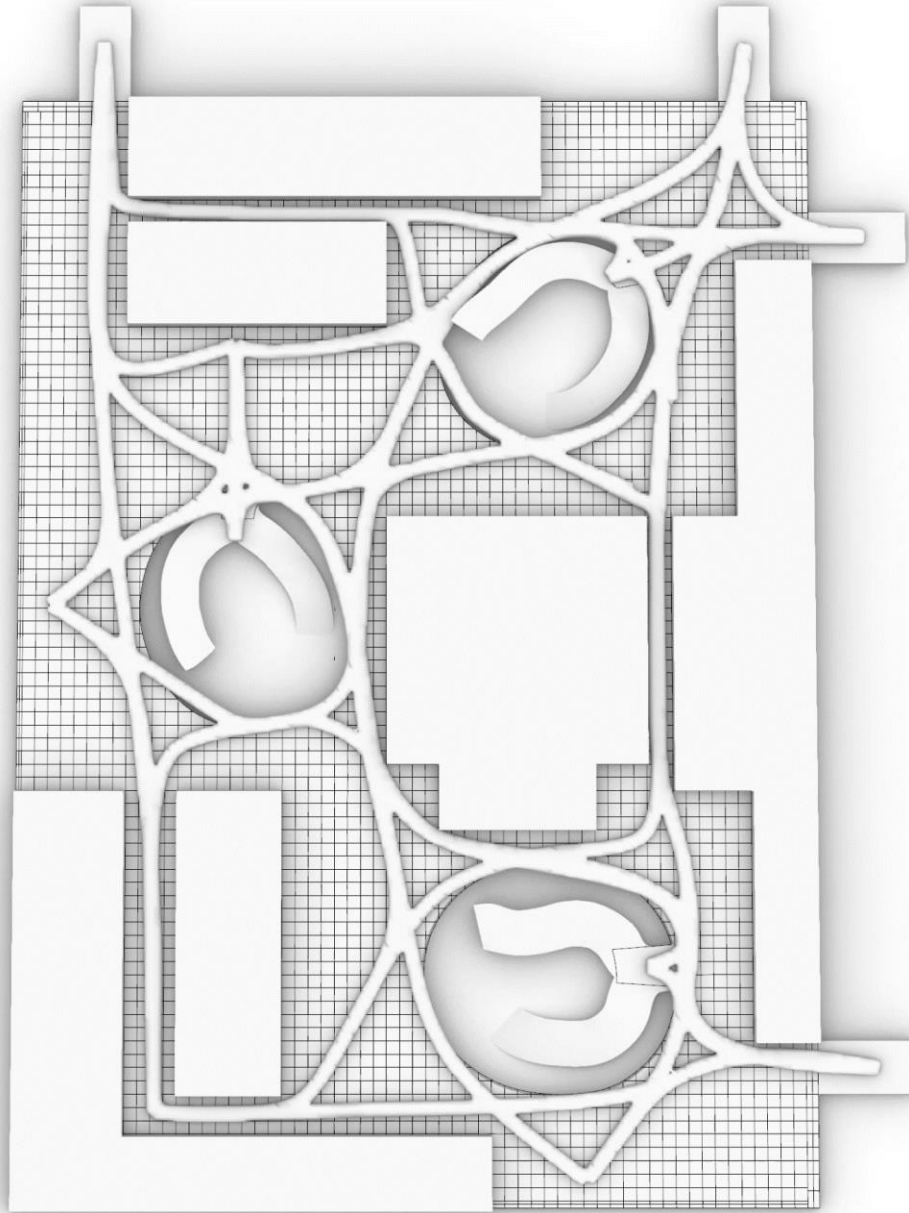

Pull strategy

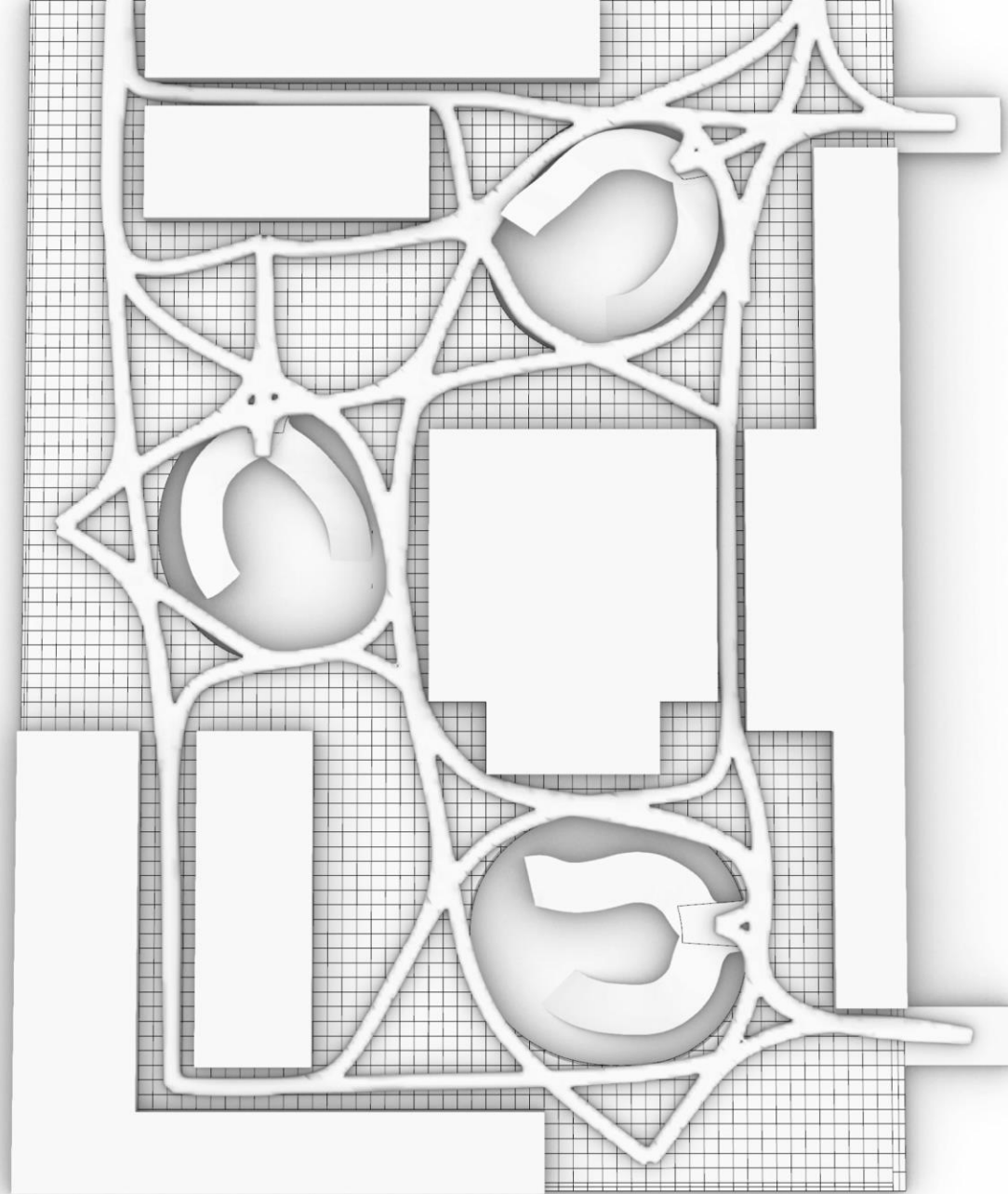

Pull strategy

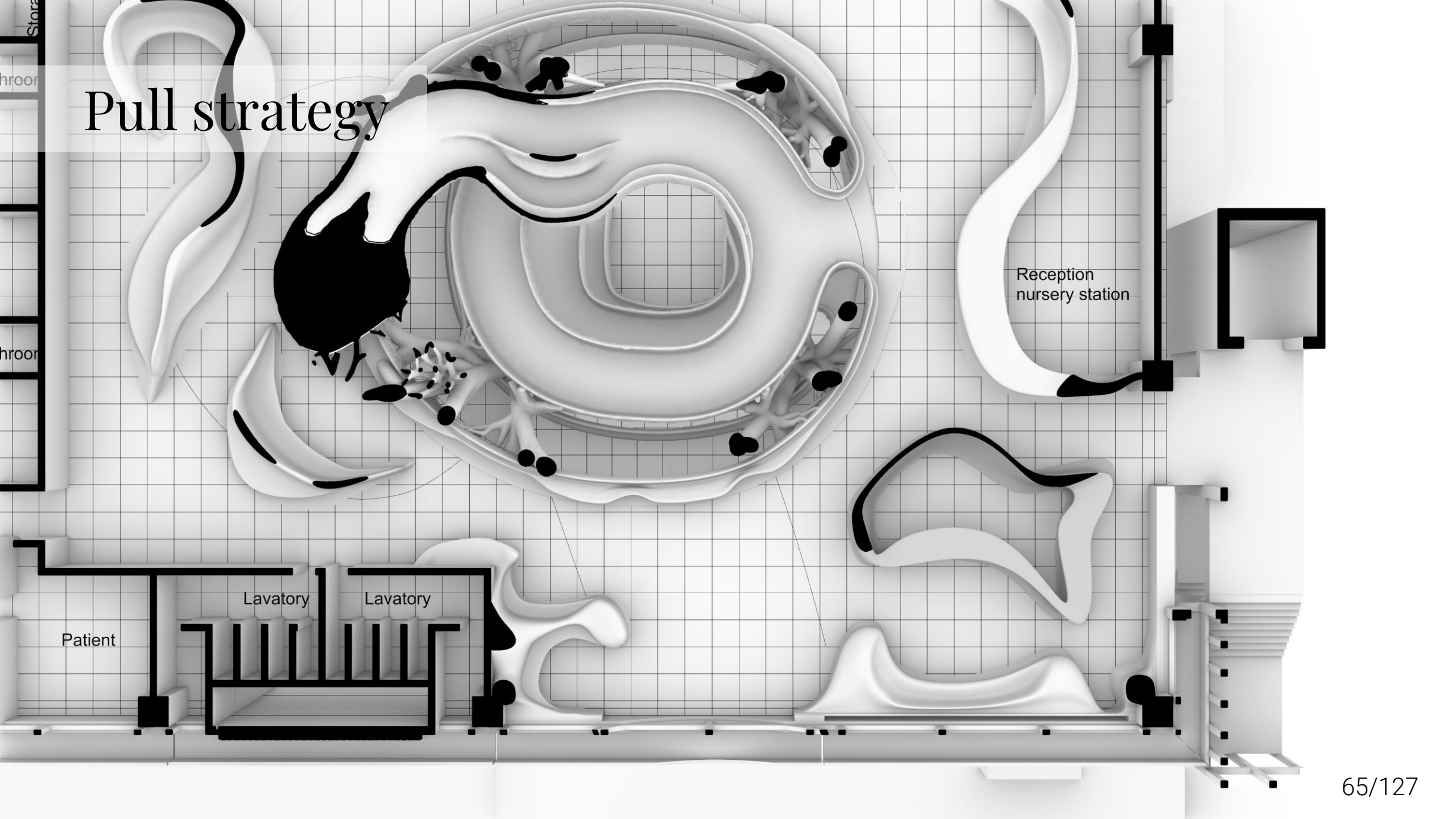

Pull strategy

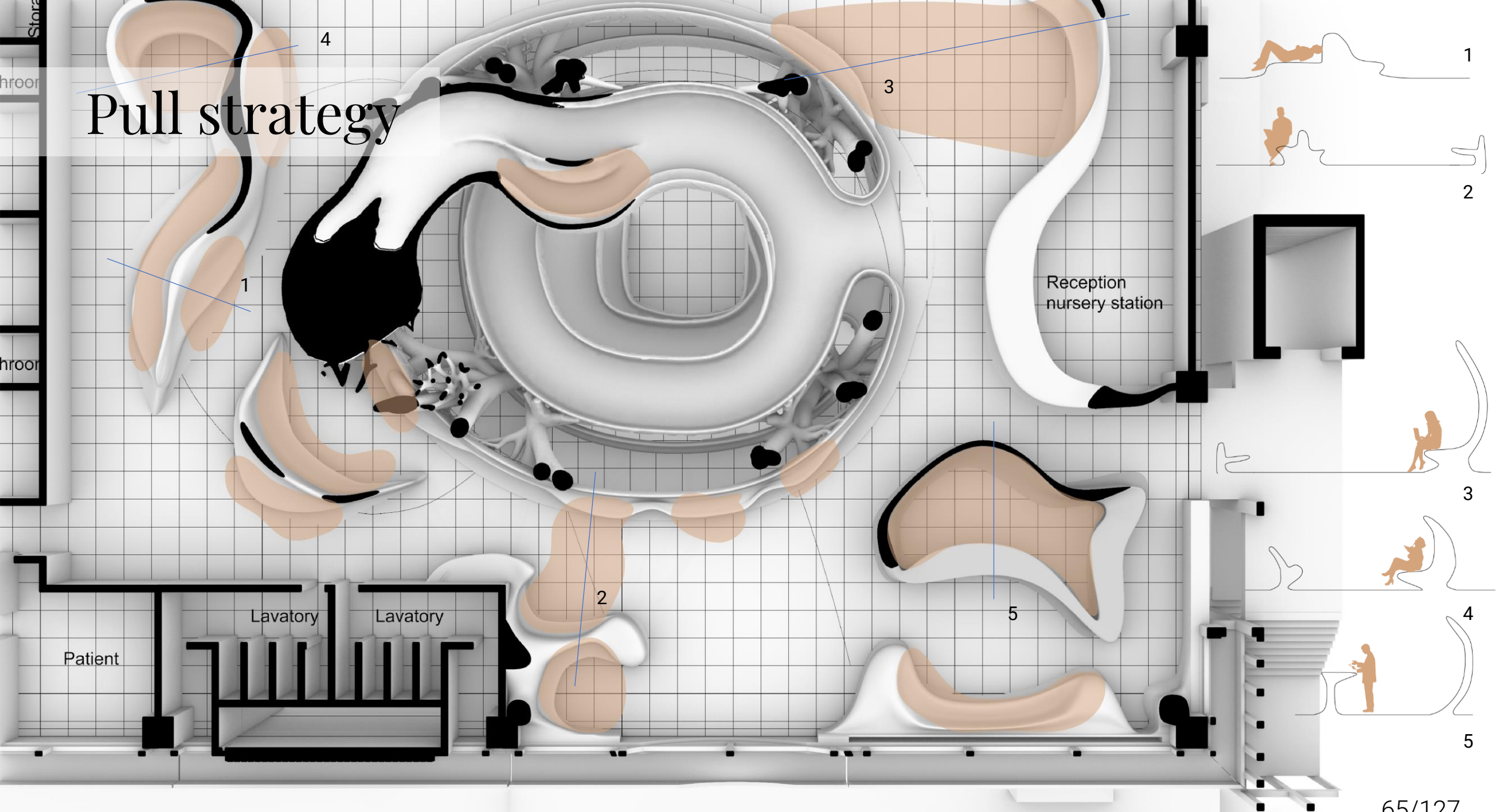

Pull strategy

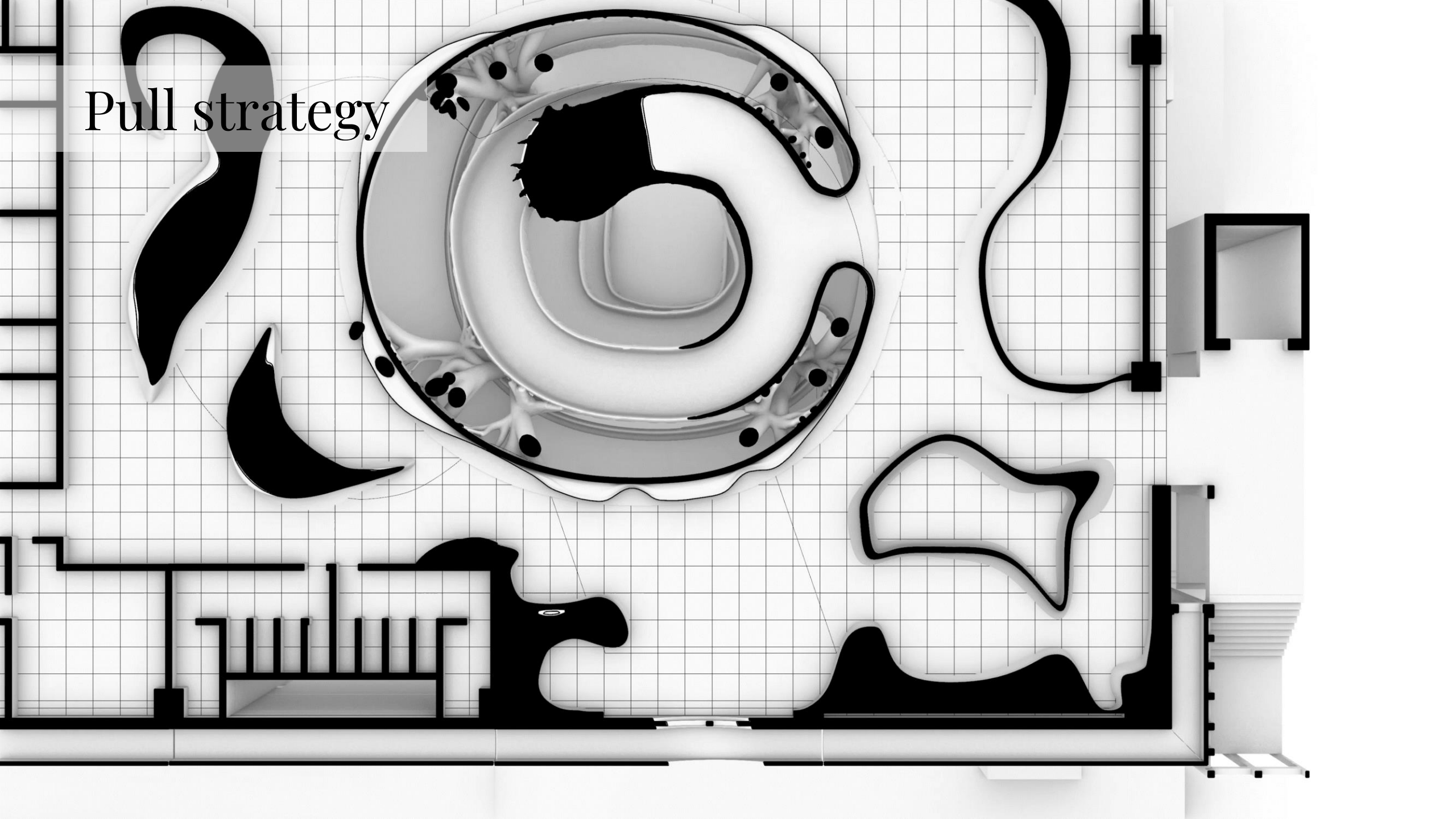

Pull strategy

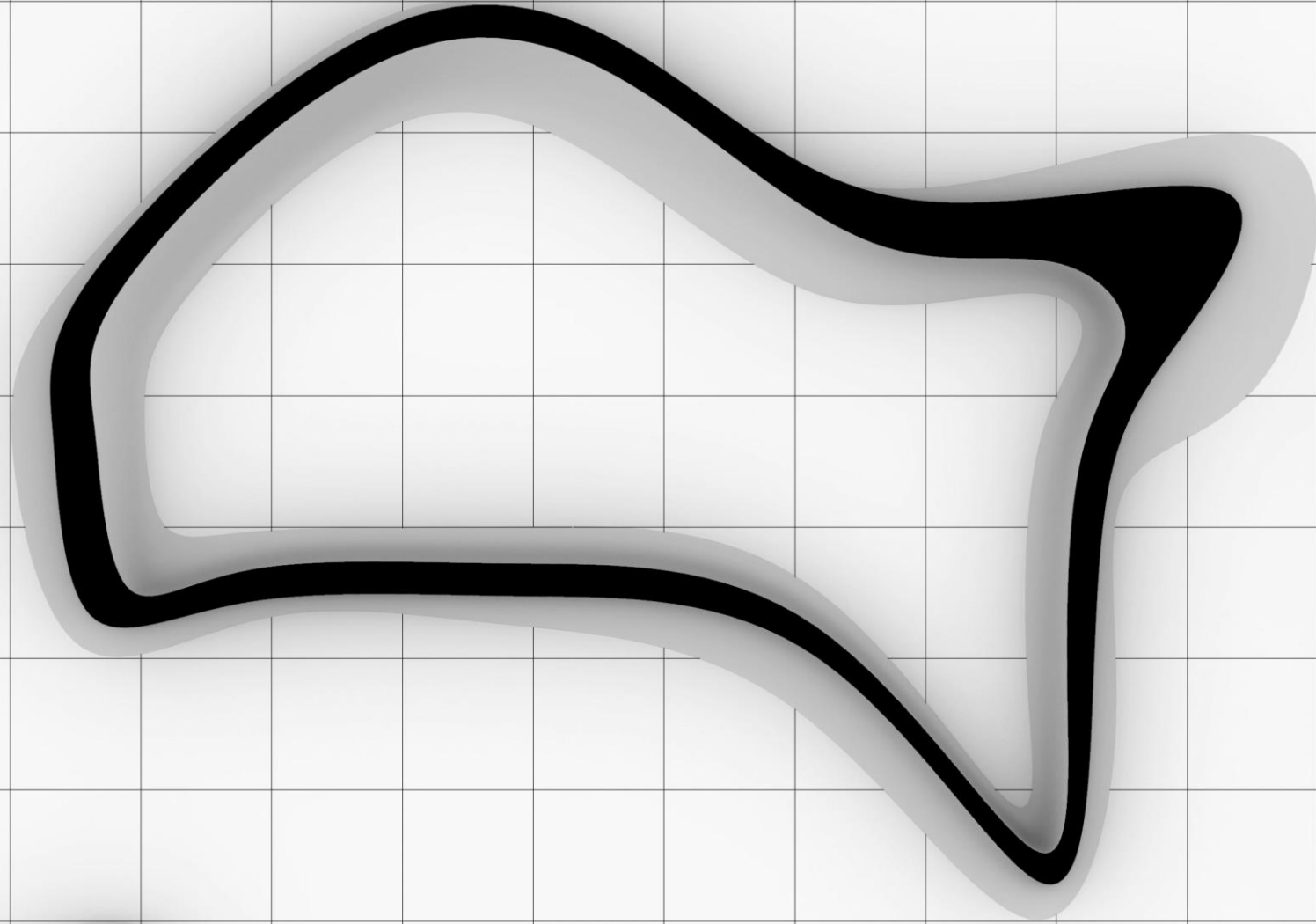

Floorplan Reference



Floorplan 00

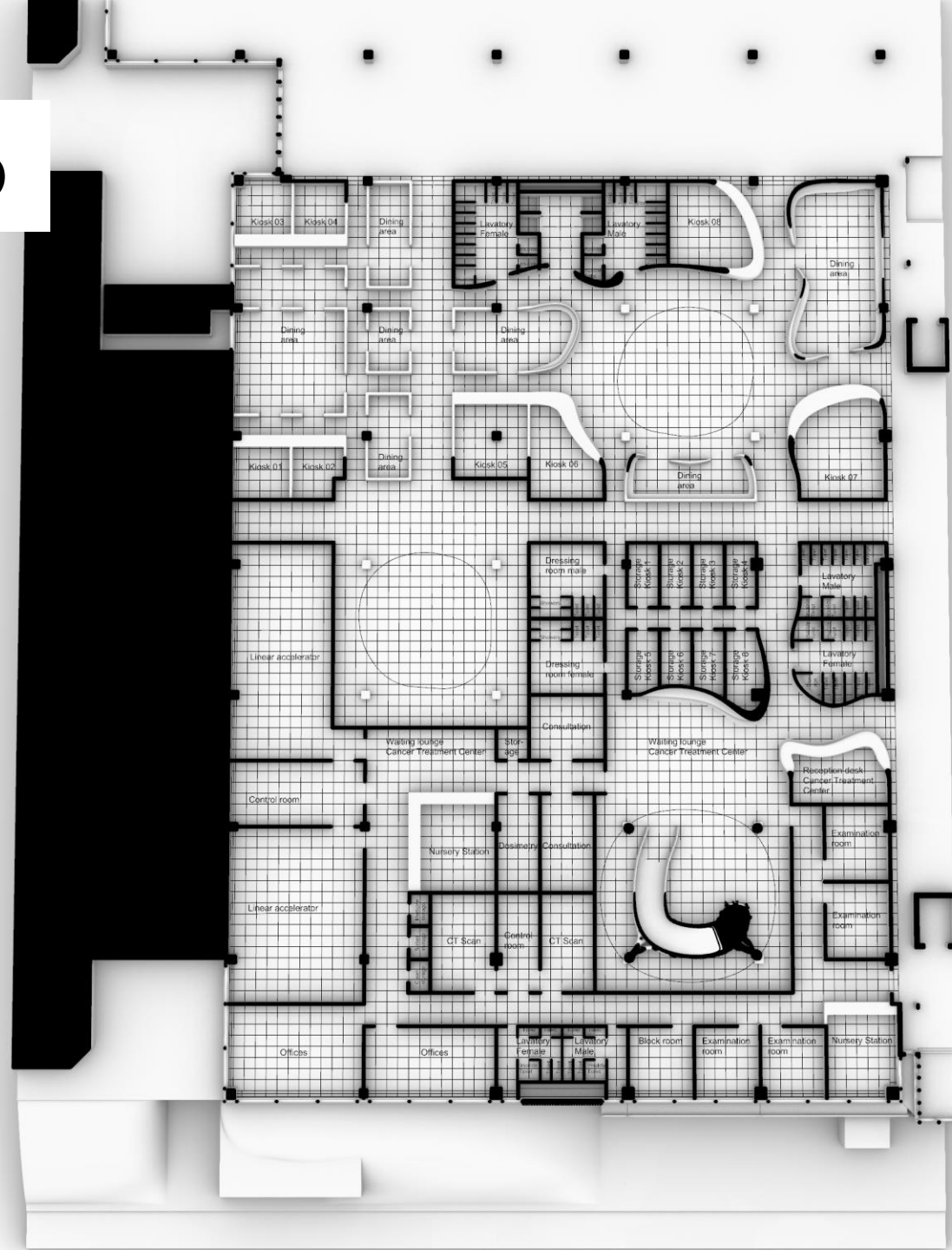

Floorplan 01



Floorplan 02

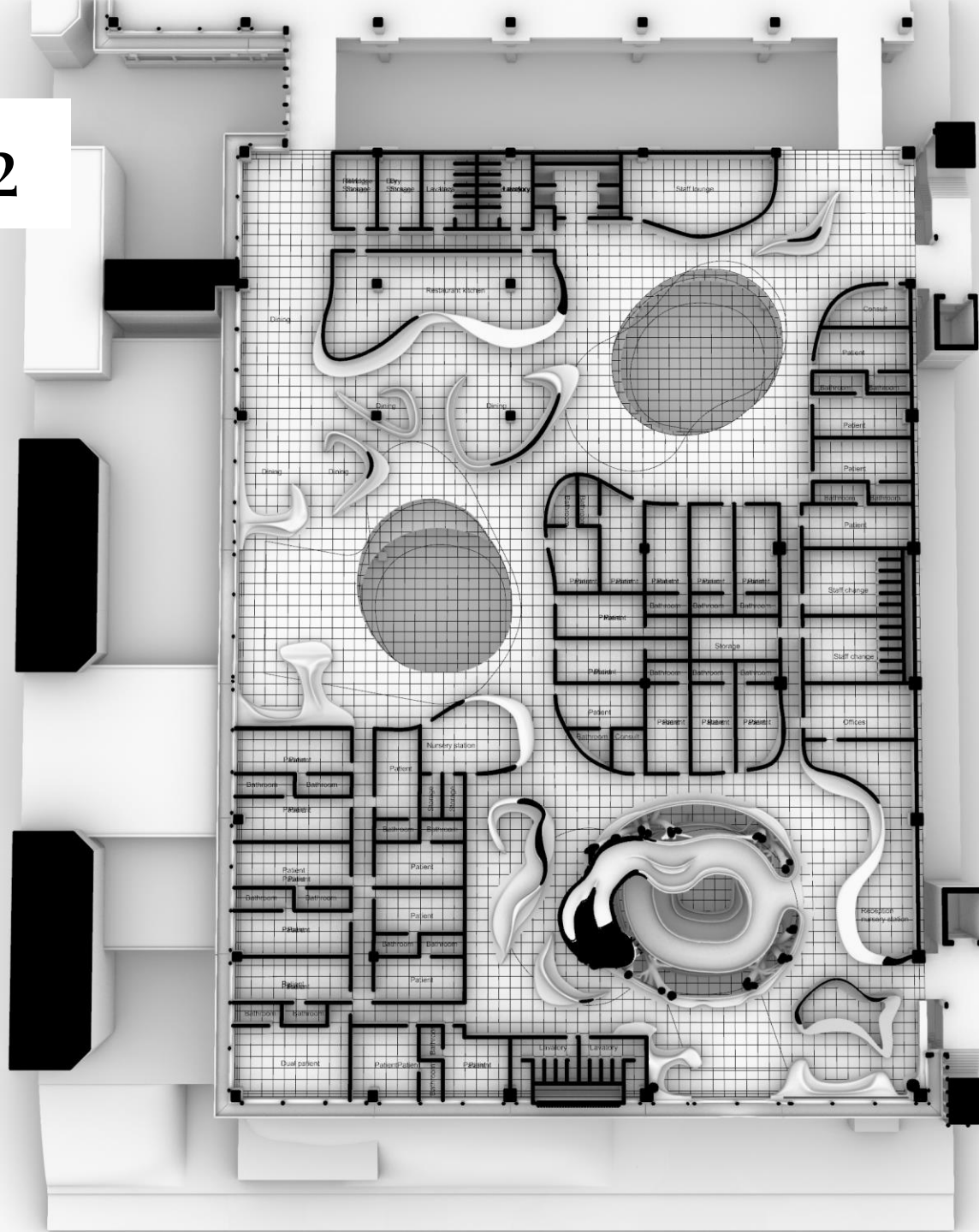

Floorplan 03



Floorplan 04

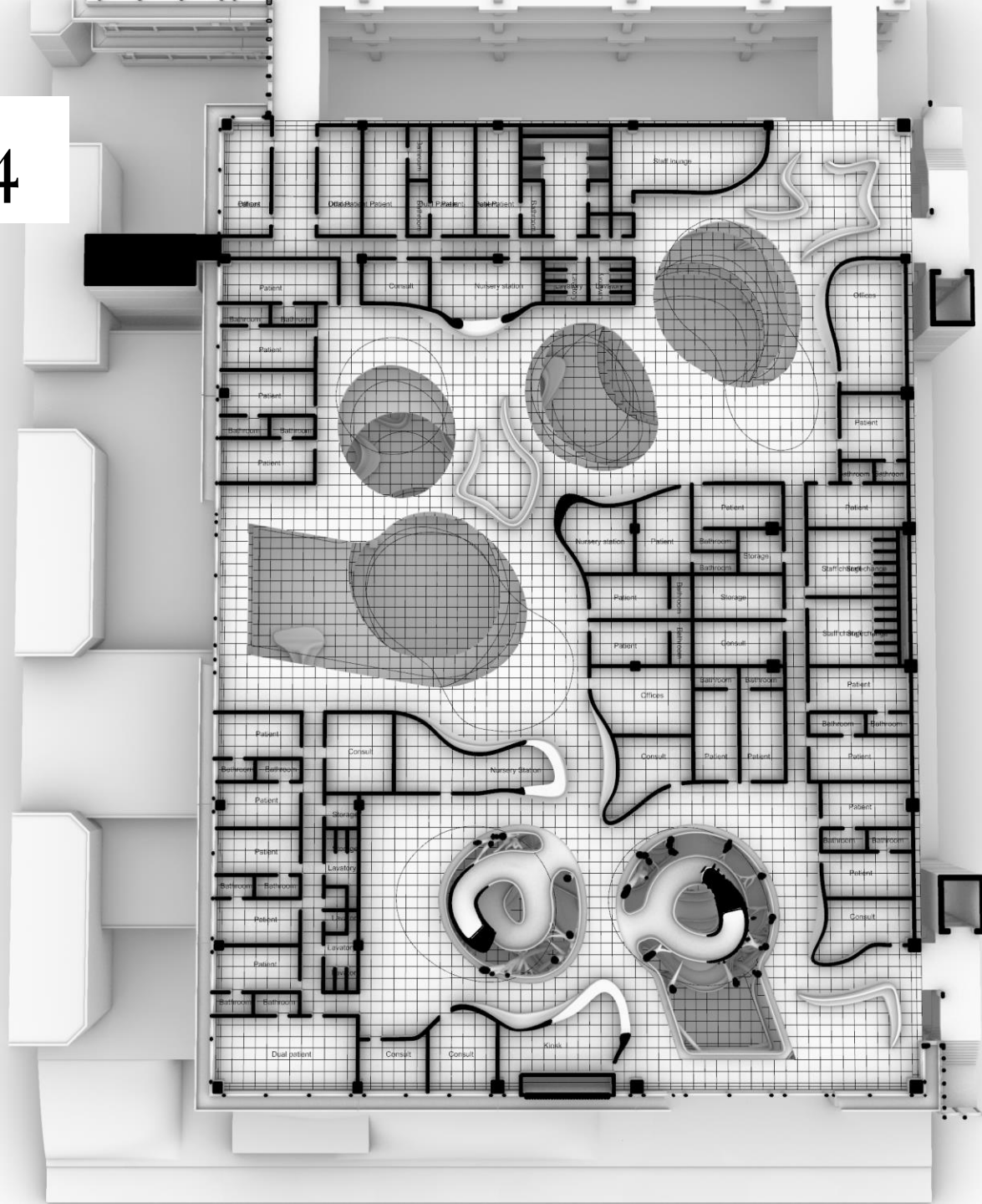

Floorplan 05

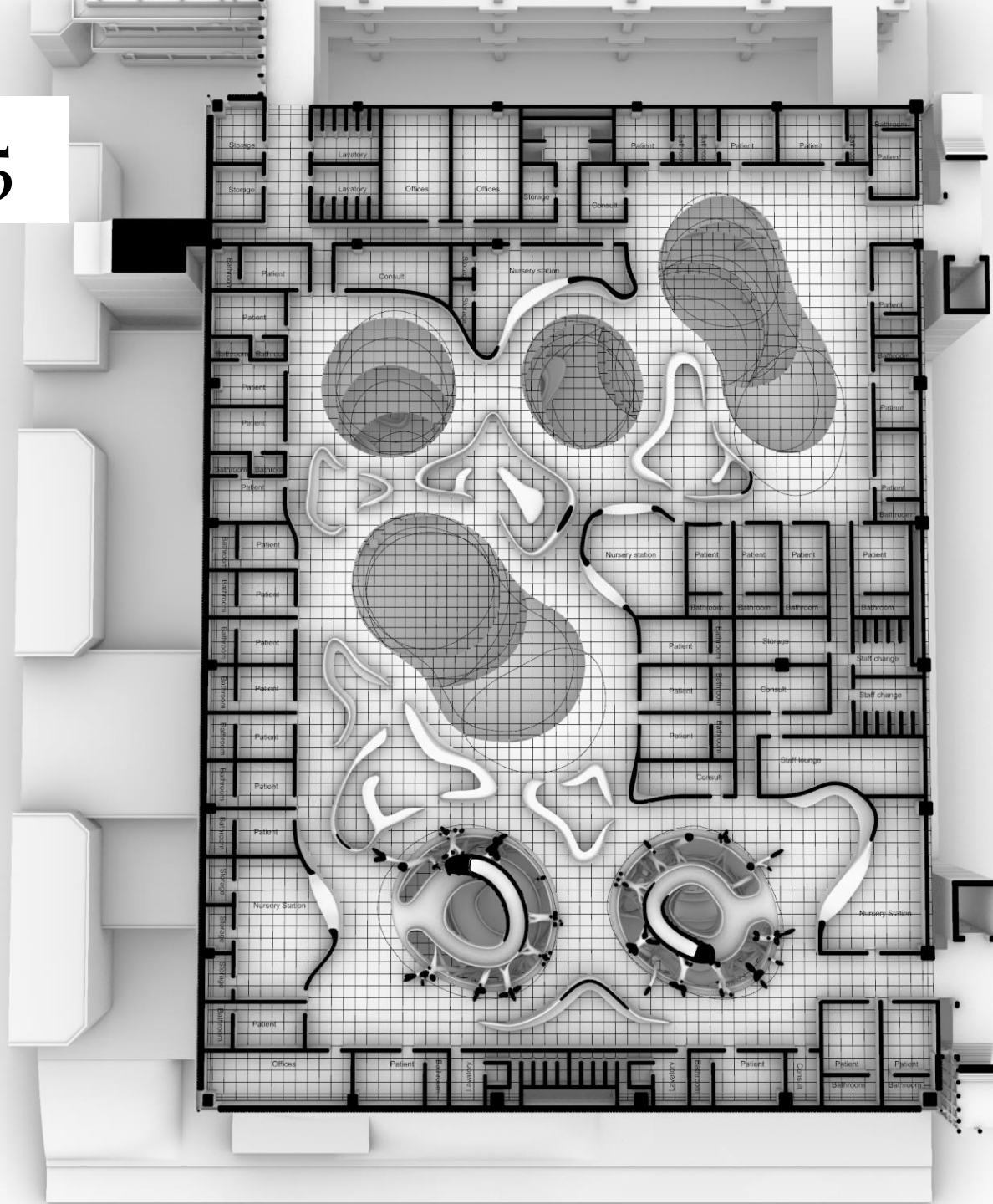

Floorplan 06

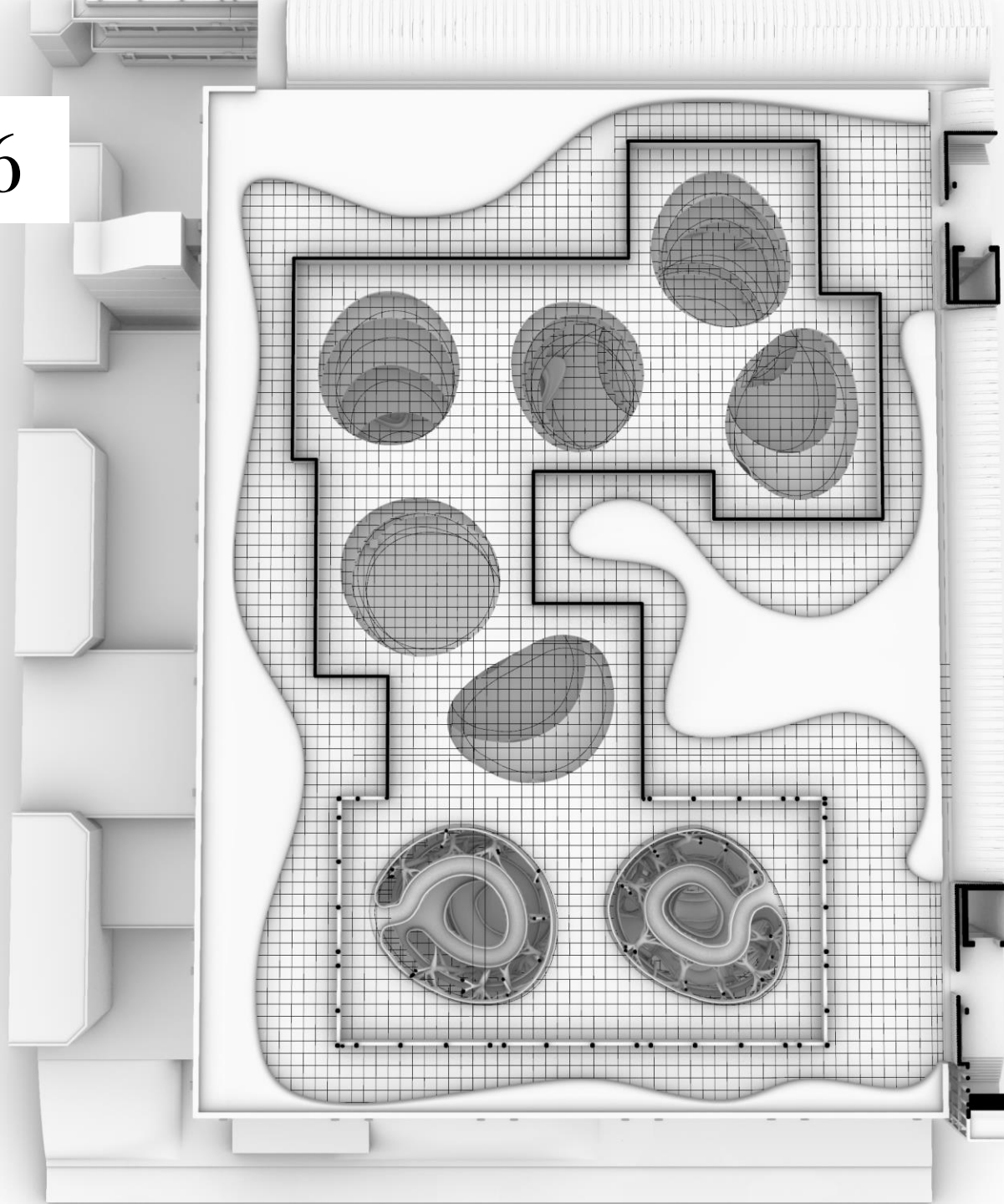

Roof

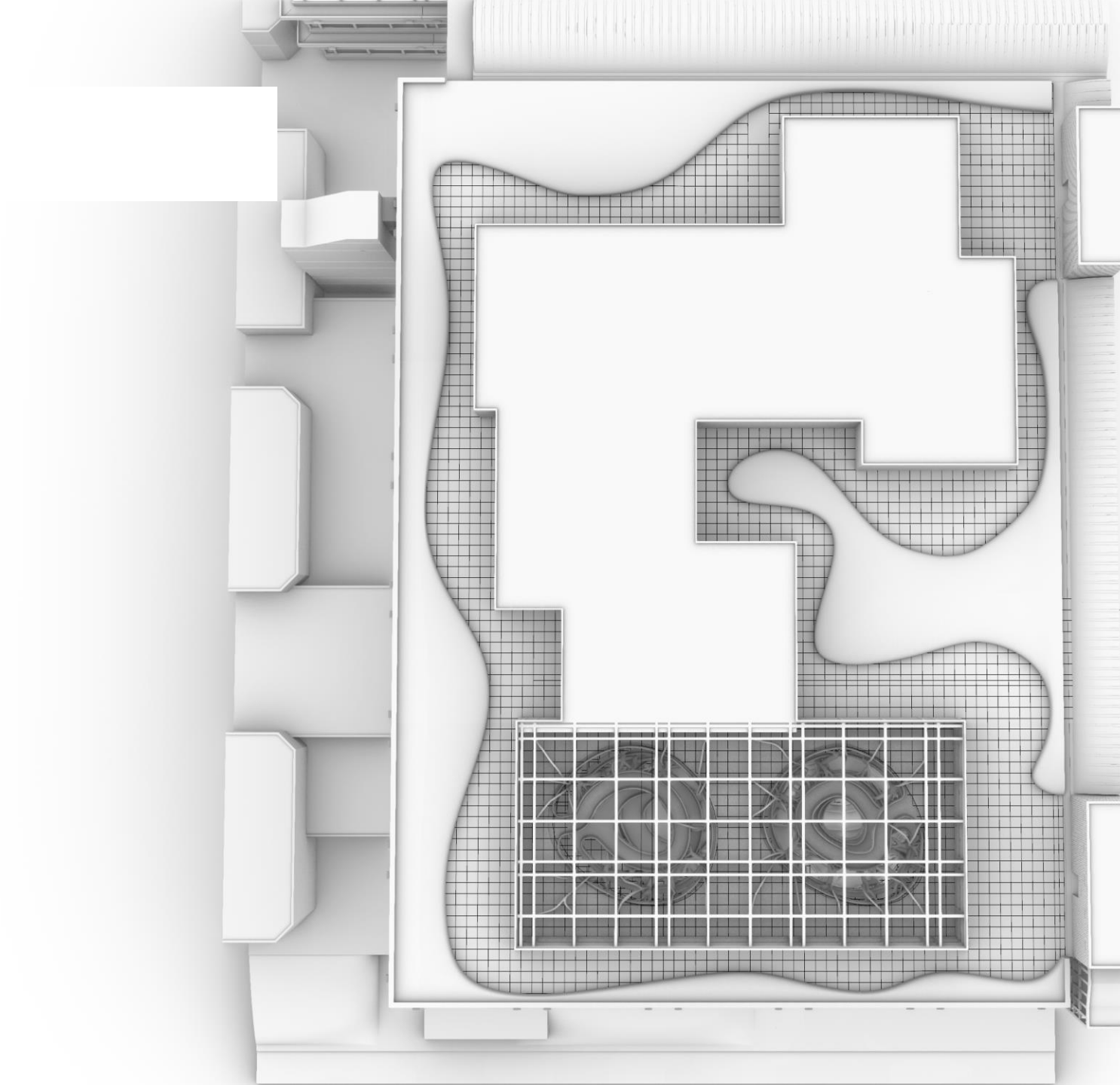

Facade

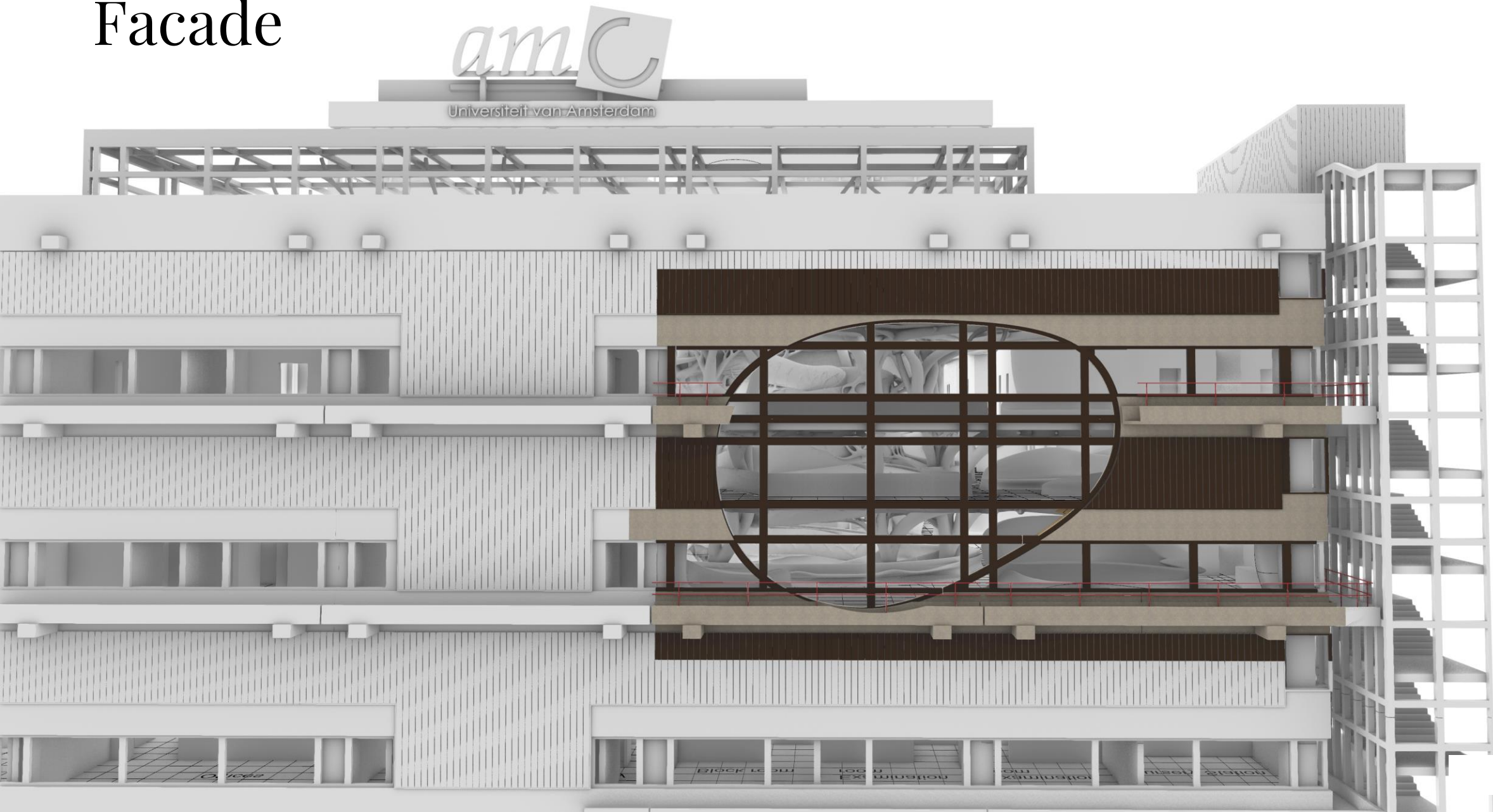

Section

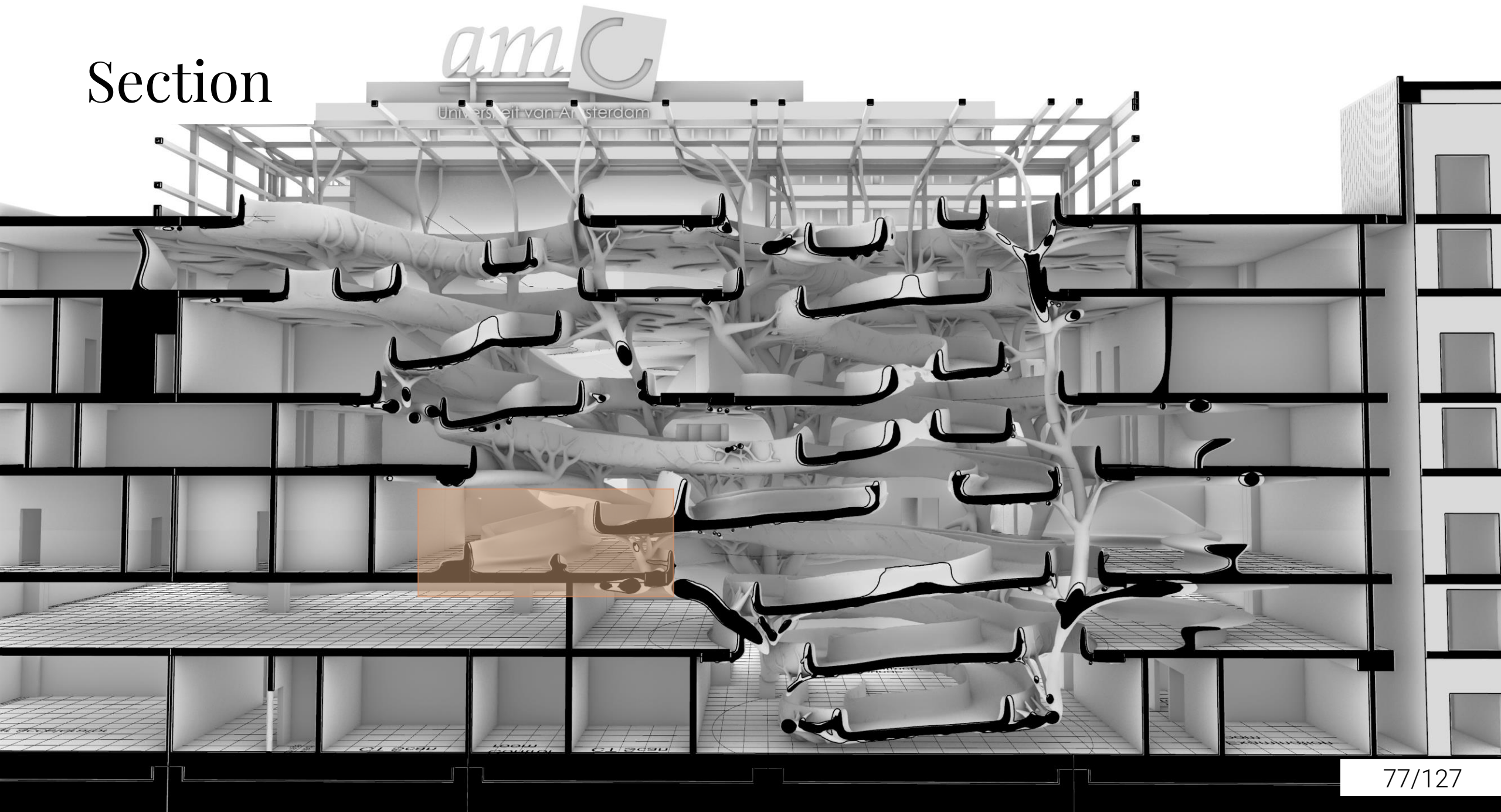

Section

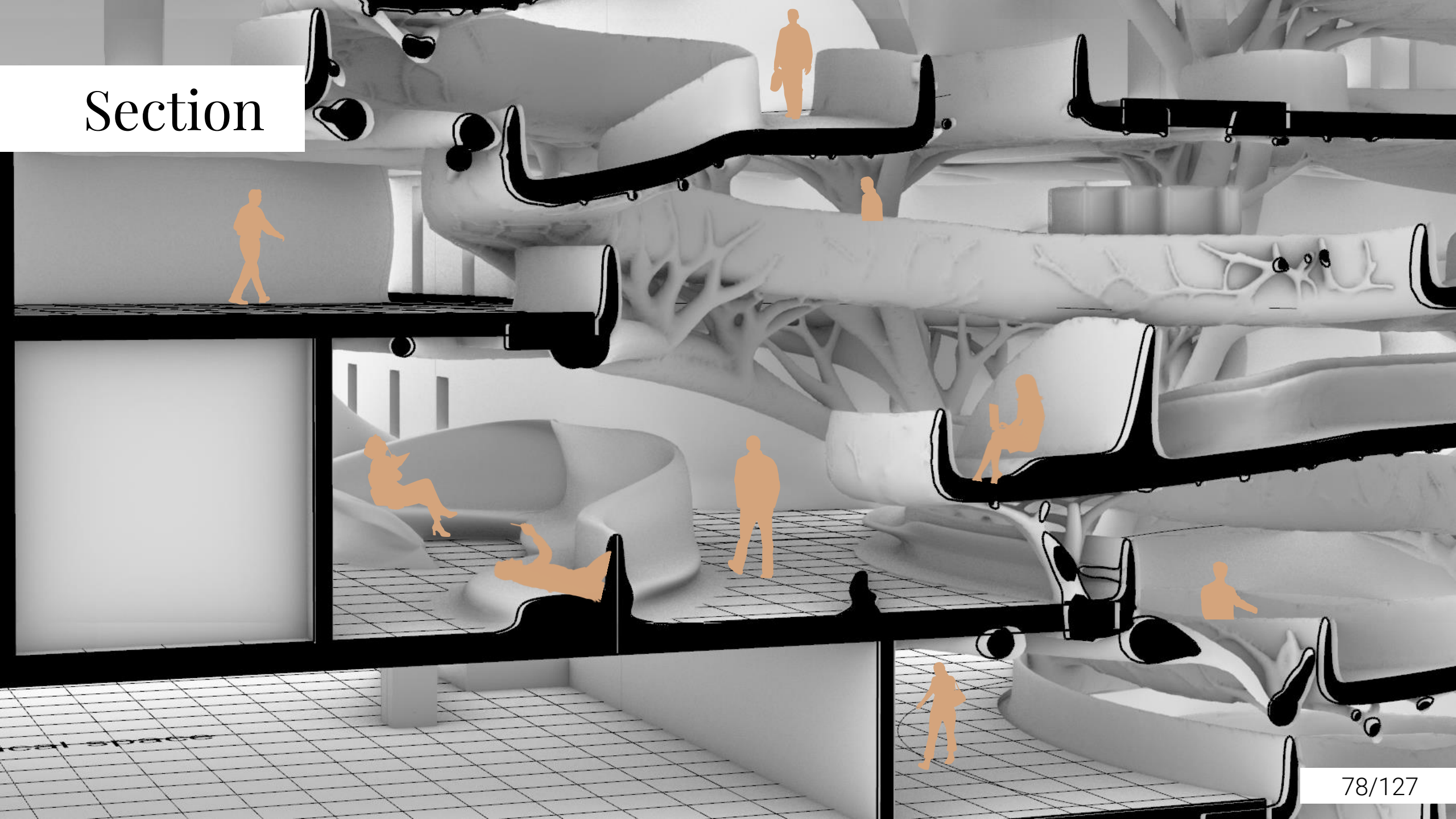

real space

Ventilation

amC
Universiteit van Amsterdam

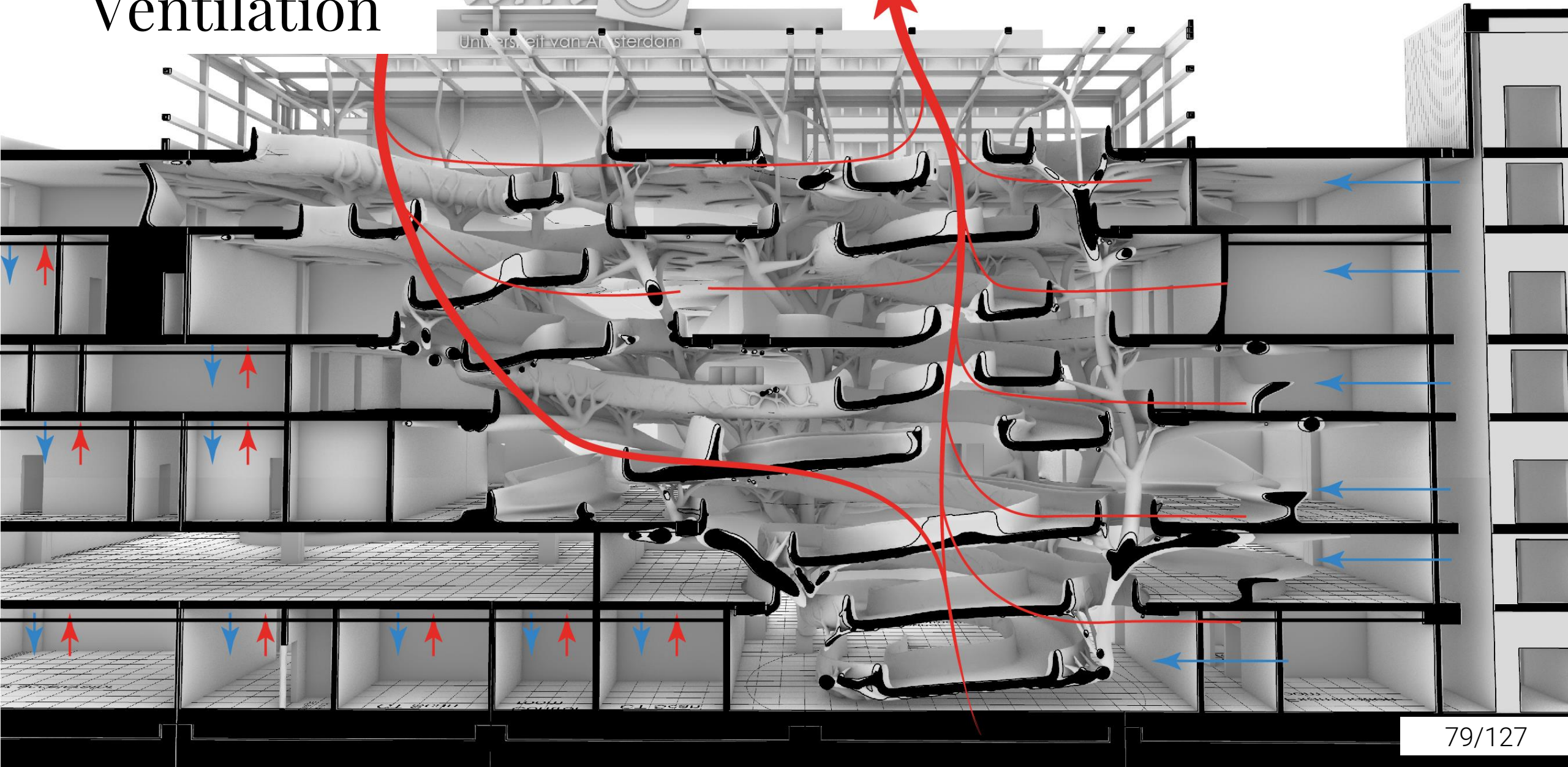



The Micro Scale

The small scale strategy

Fragment

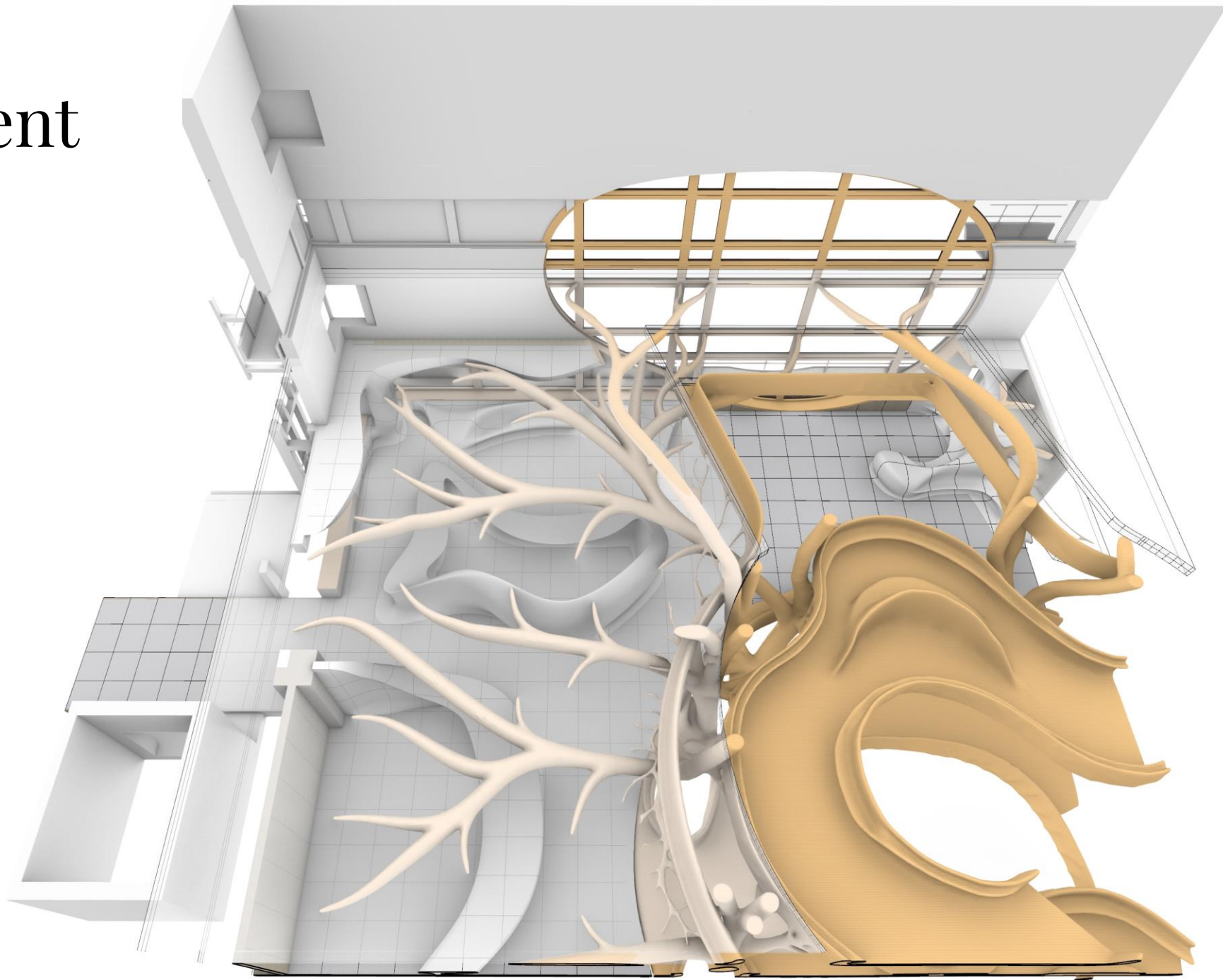

Facade

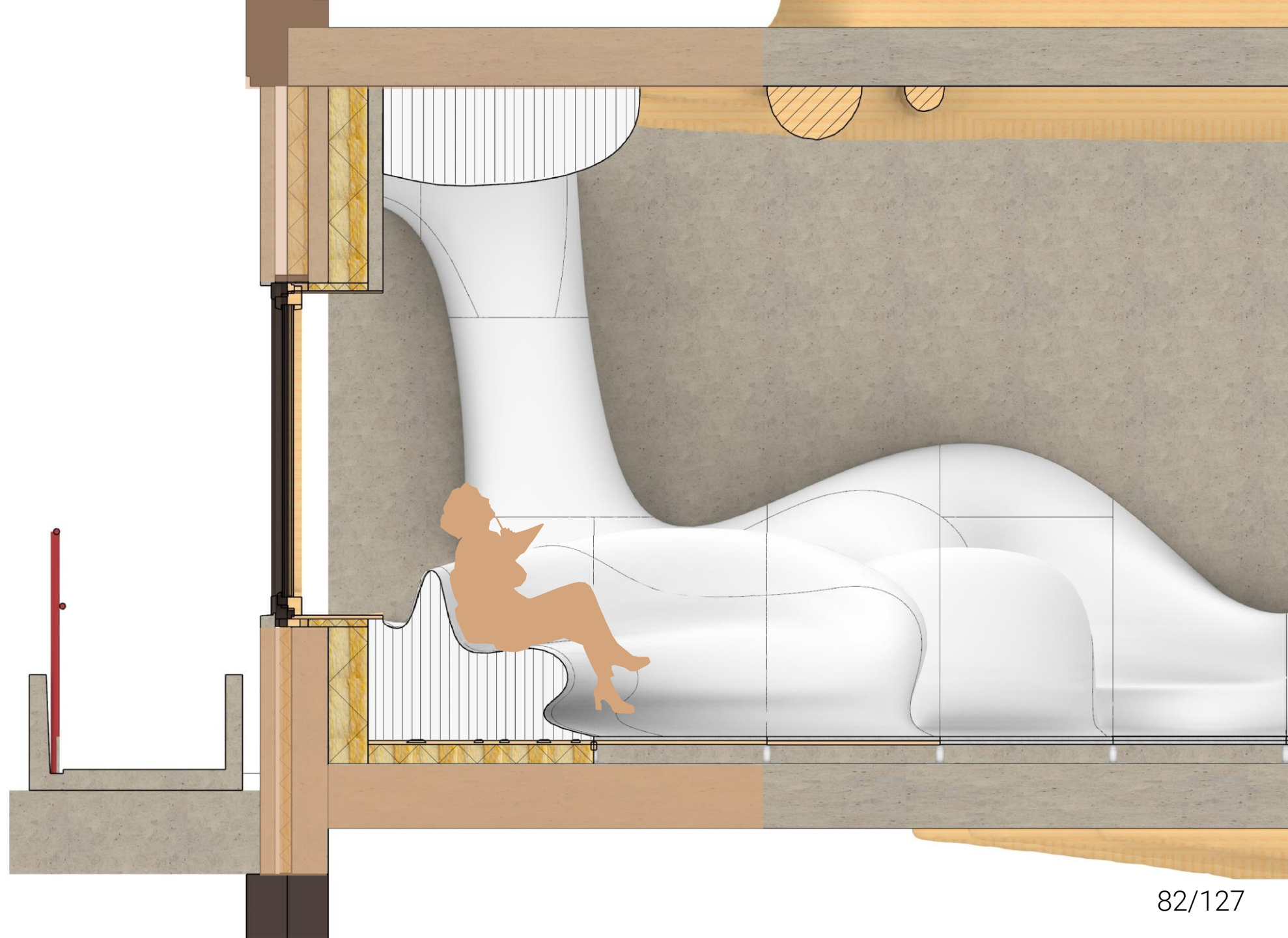
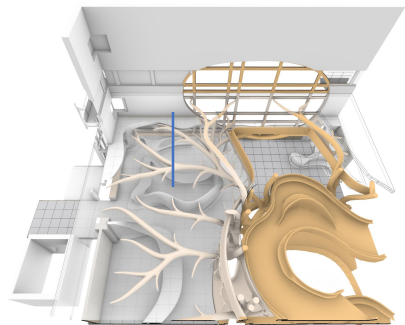

Facade



Near zero connection

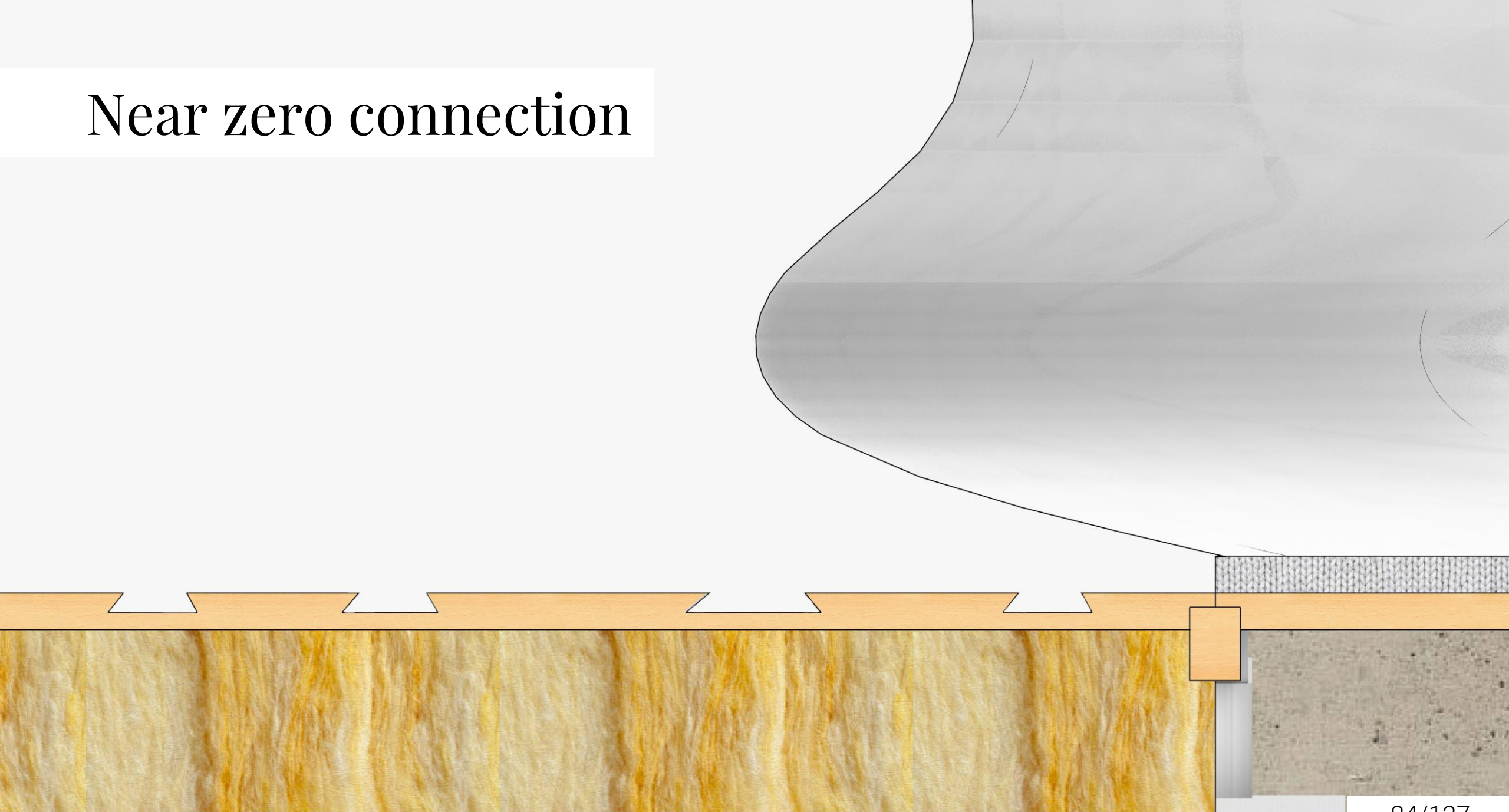

Atria connection

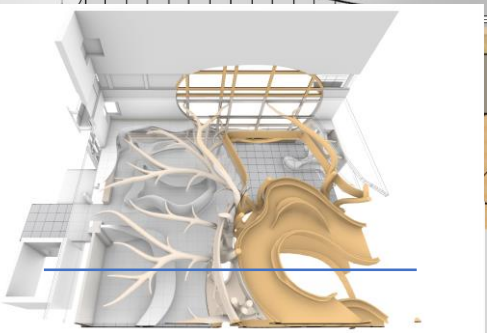
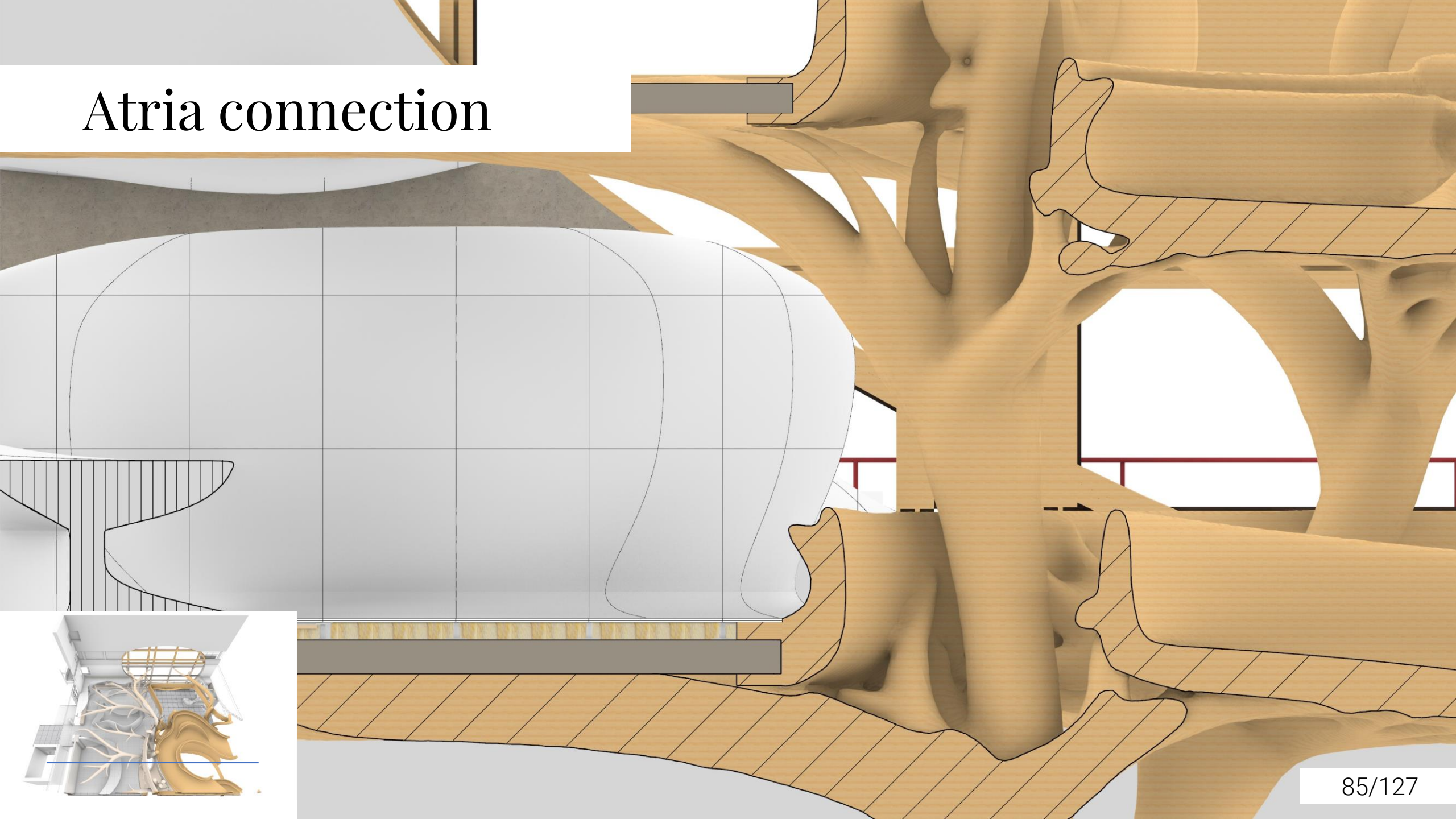

Nature strategy



Reindeer Moss



Areca Palm



Elephant Ear
Philodendron



English Ivy



Boston Fern



Bamboo



Golden Pothos

Nature strategy



Medicinal herbs



Fruit trees



Nature strategy

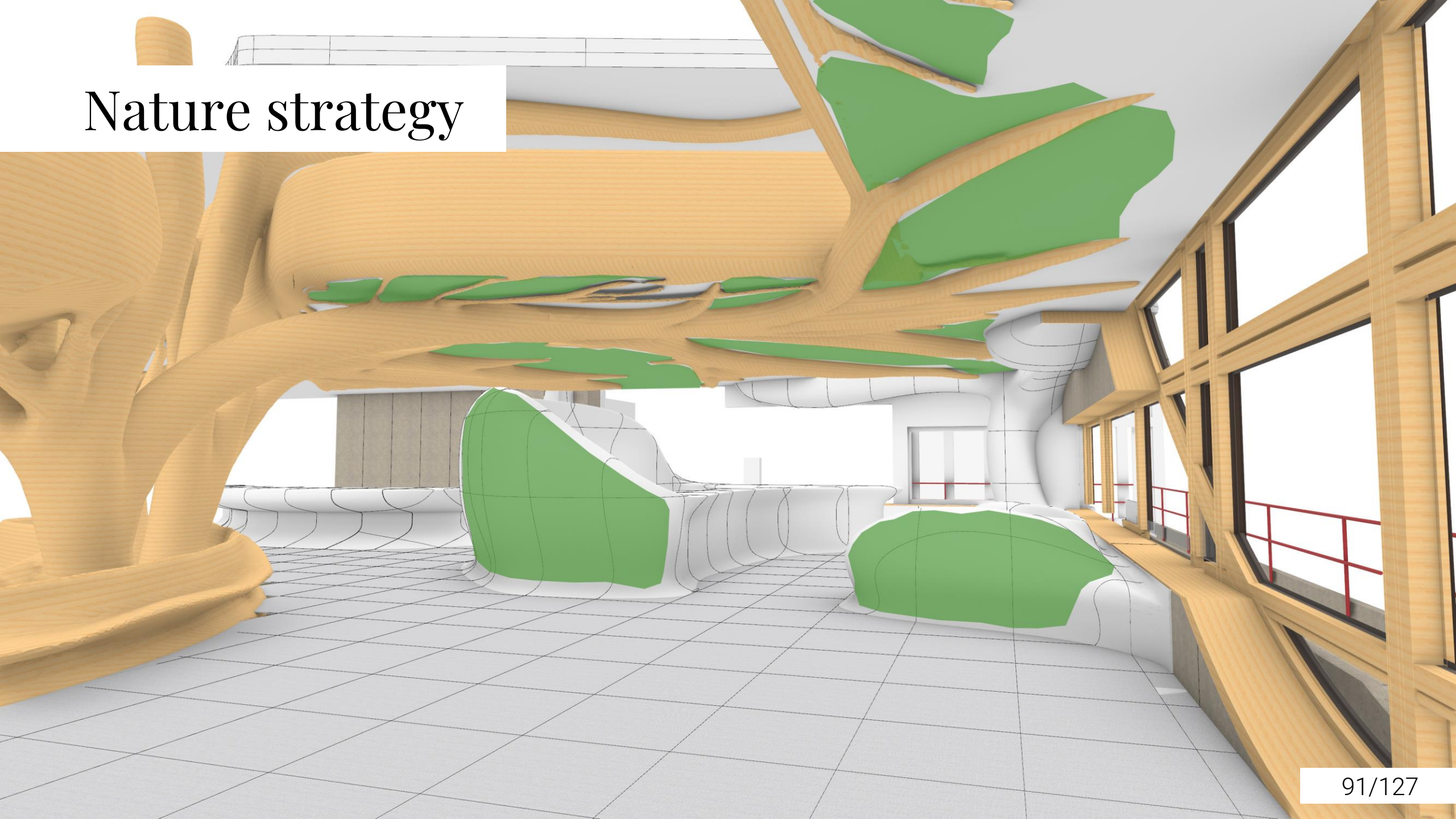

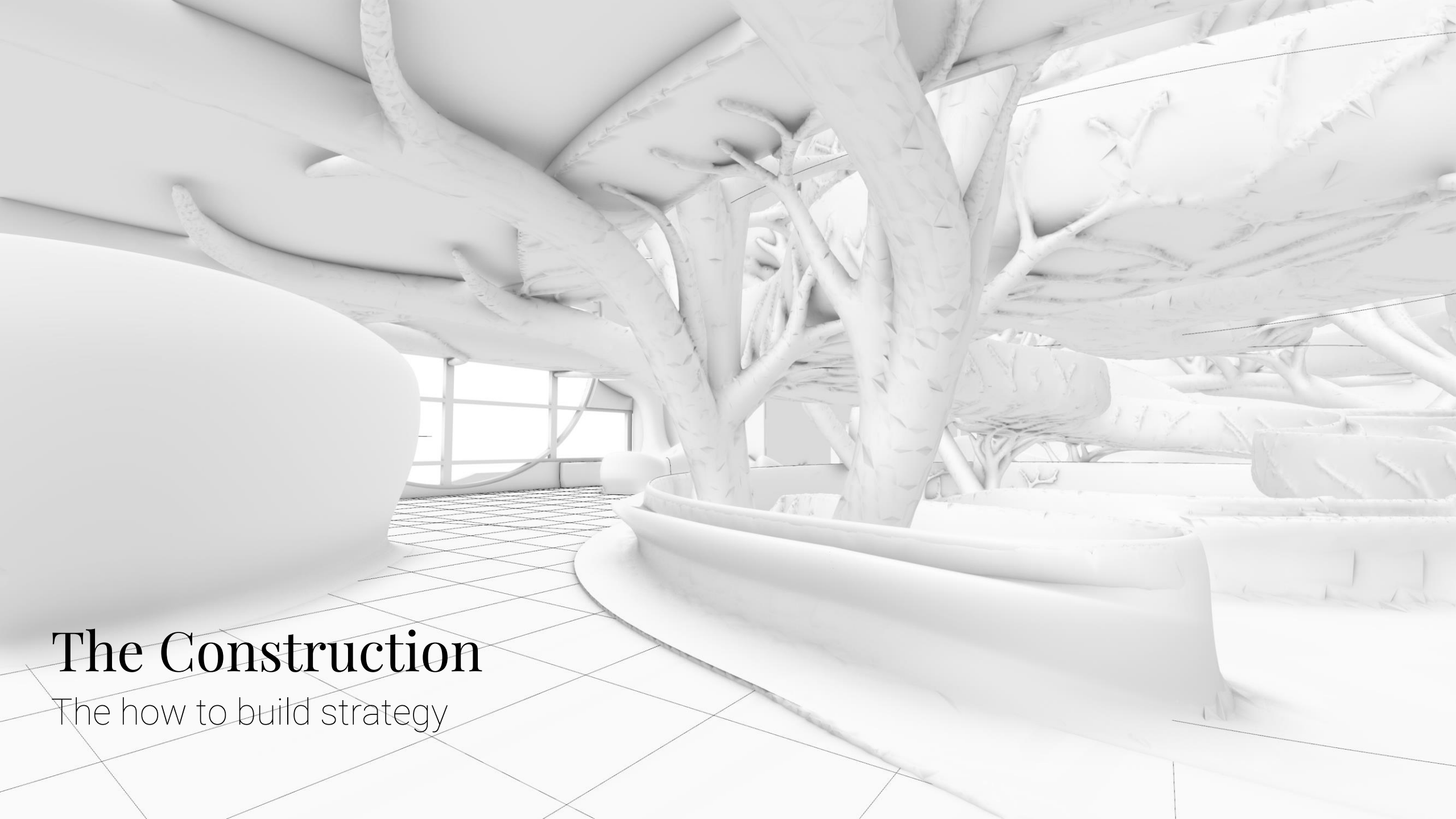

The Construction

The how to build strategy



Wood

Workshop HvA

The background features a white, crumpled paper object on the right side, which appears to be a piece of paper that has been folded and then crumpled. A dense network of thin, grey lines radiates from the center of the crumpled paper, extending across the entire frame. The lines are thin and create a complex, web-like pattern that fills the space.

Workshop HvA



Workshop HvA



Waste material

Mycelium



Mycelium

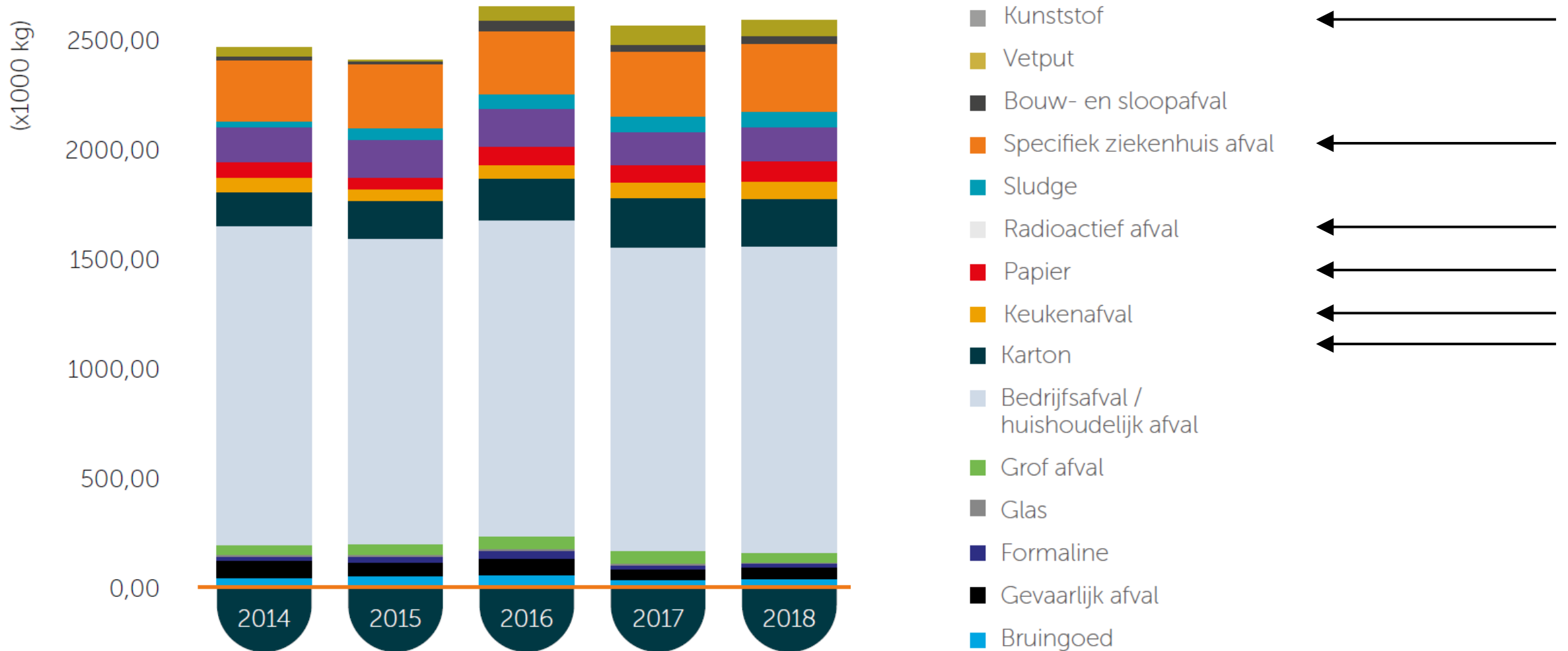

Mycelium

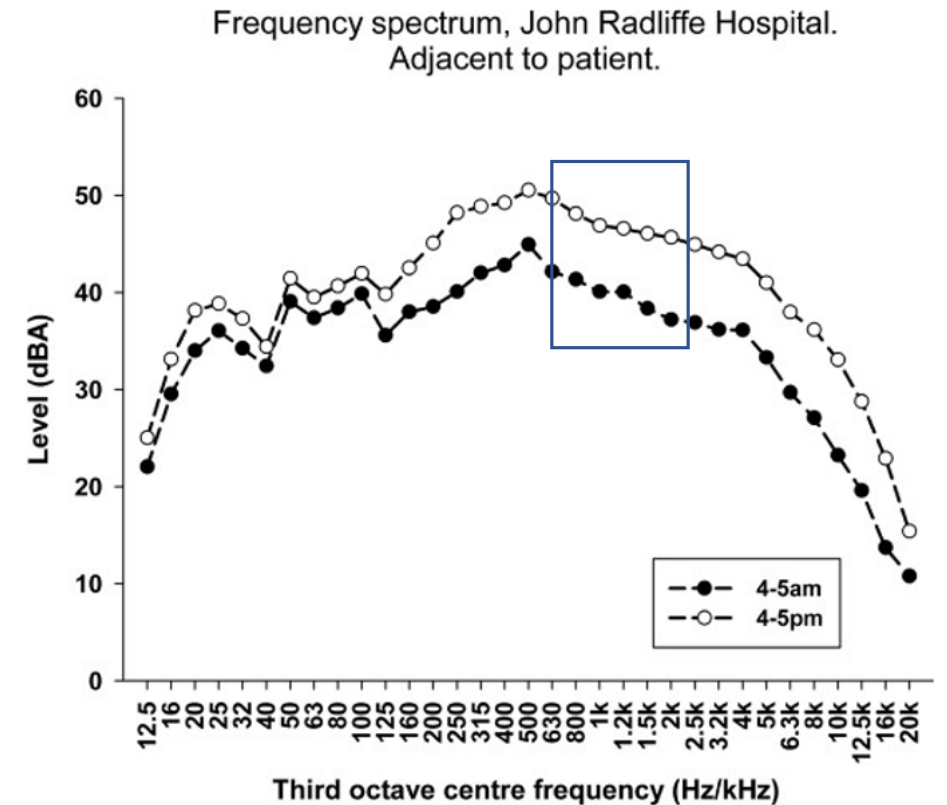
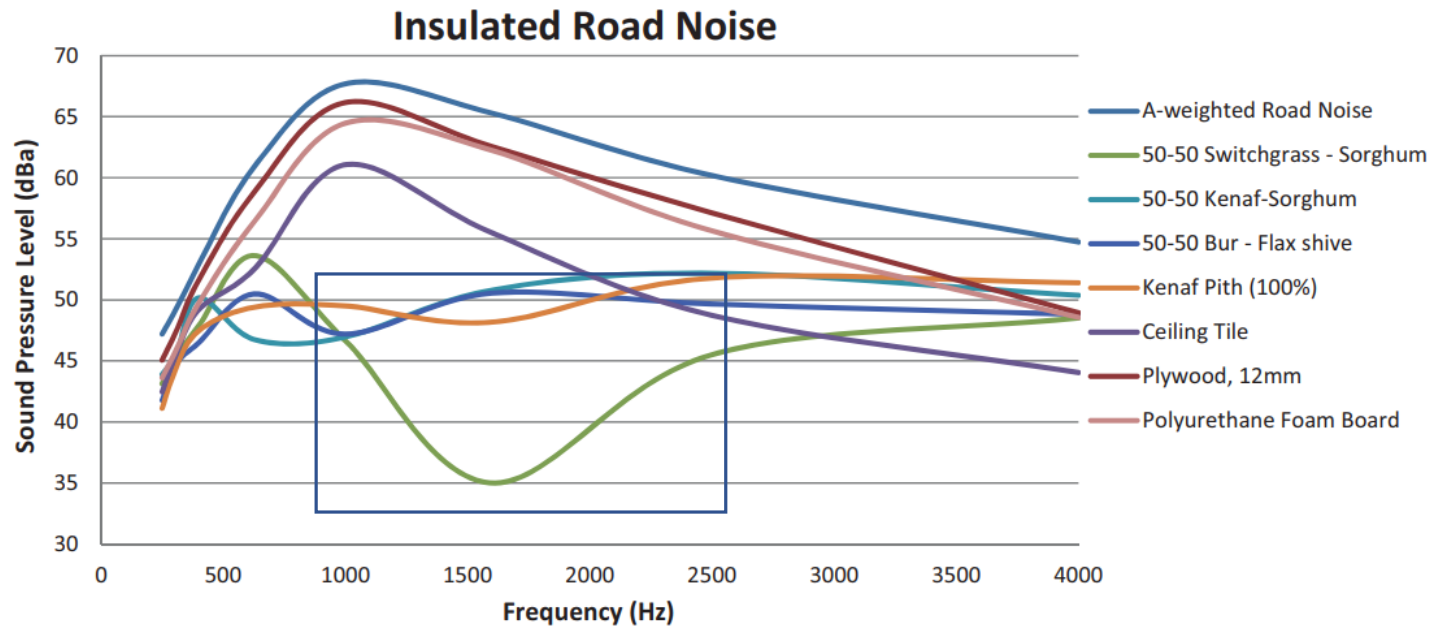
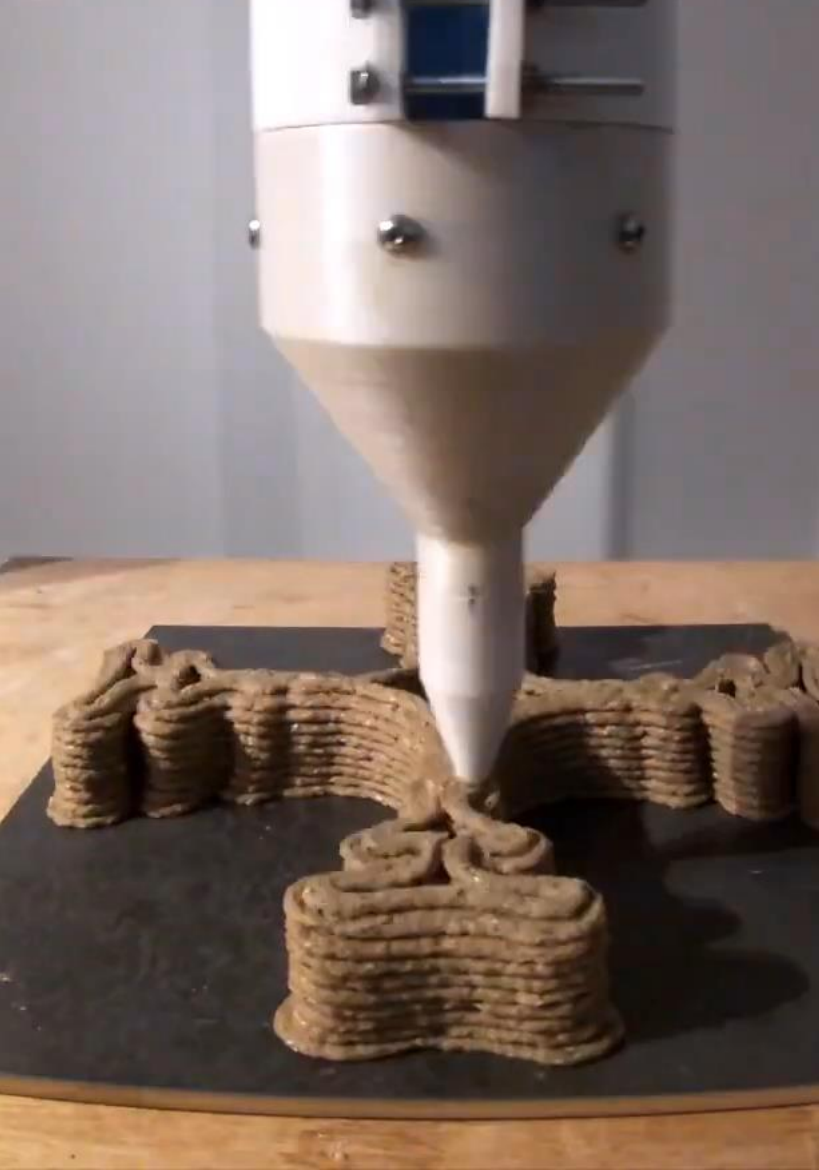

Figure 5 Frequency plot for 24 hours at John Radcliffe Hospital ICU. Frequency components of the noise adjacent to a patient at the John Radcliffe Hospital Adult ICU on a weekday at the quietest period (4:00 AM to 5:00 AM) and during working hours (4:00 PM to 5:00 PM).

Mycelium benefits



Mycelium printing



Production Strategy

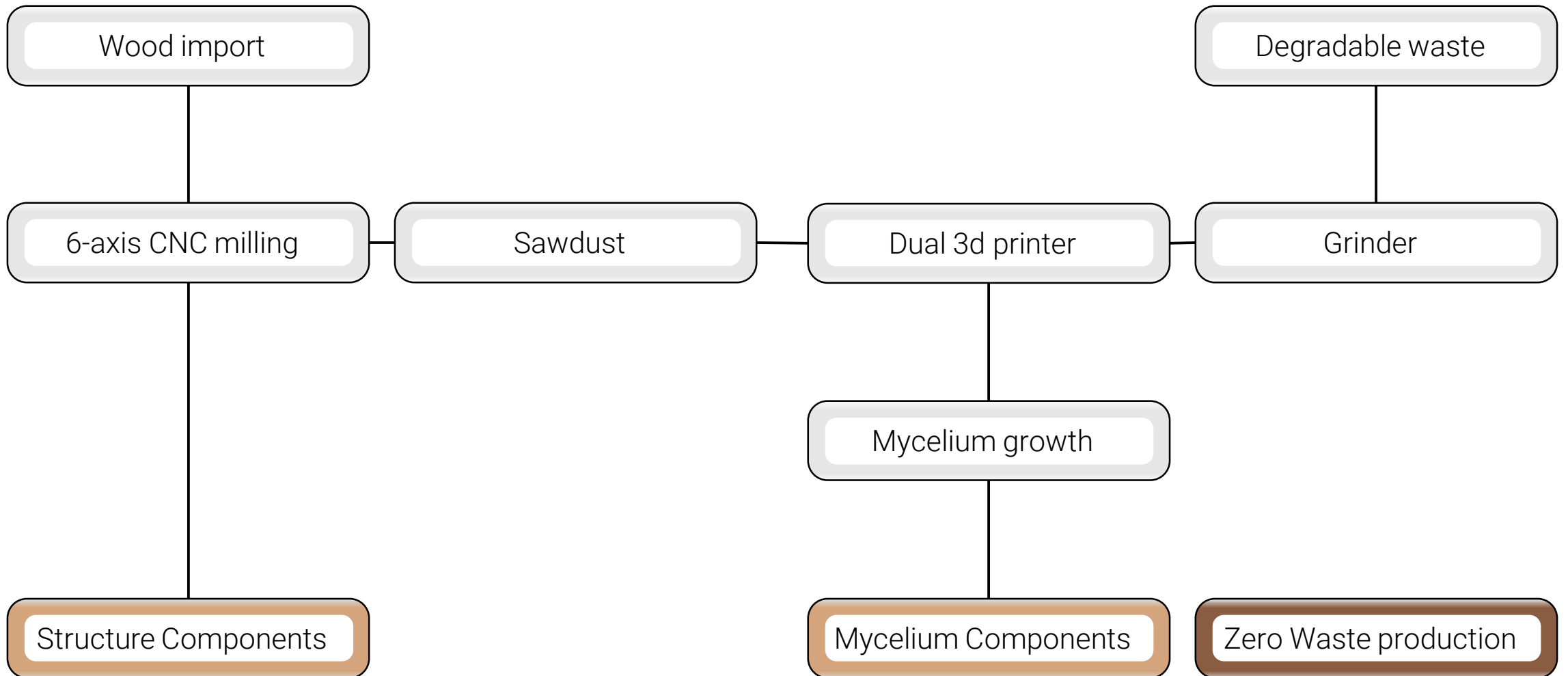

Wood construction



Wood construction

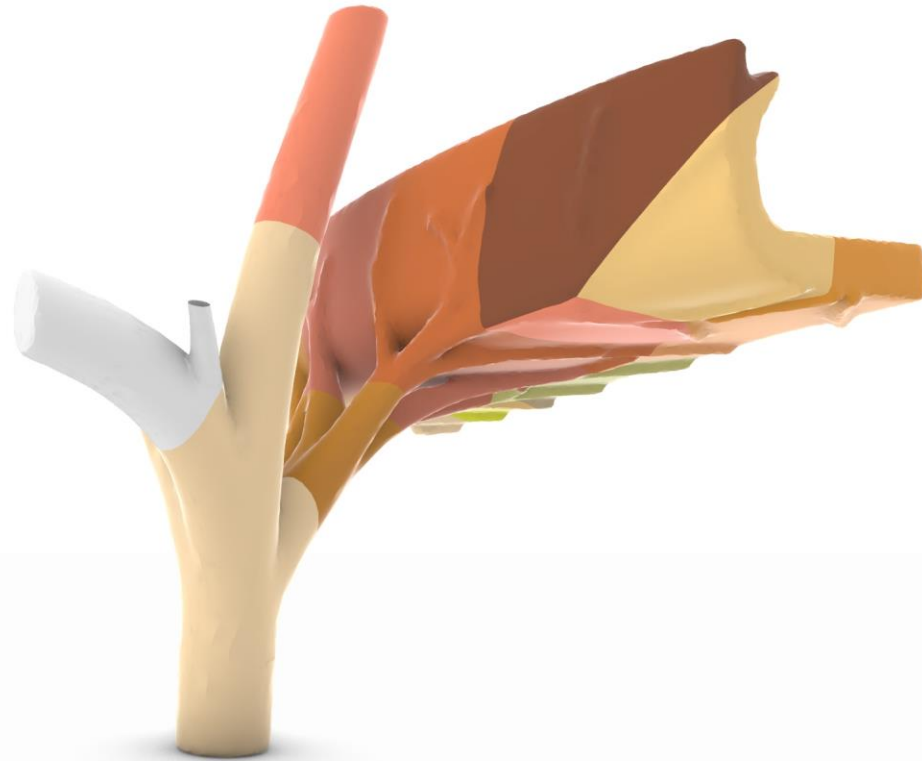

Wood construction

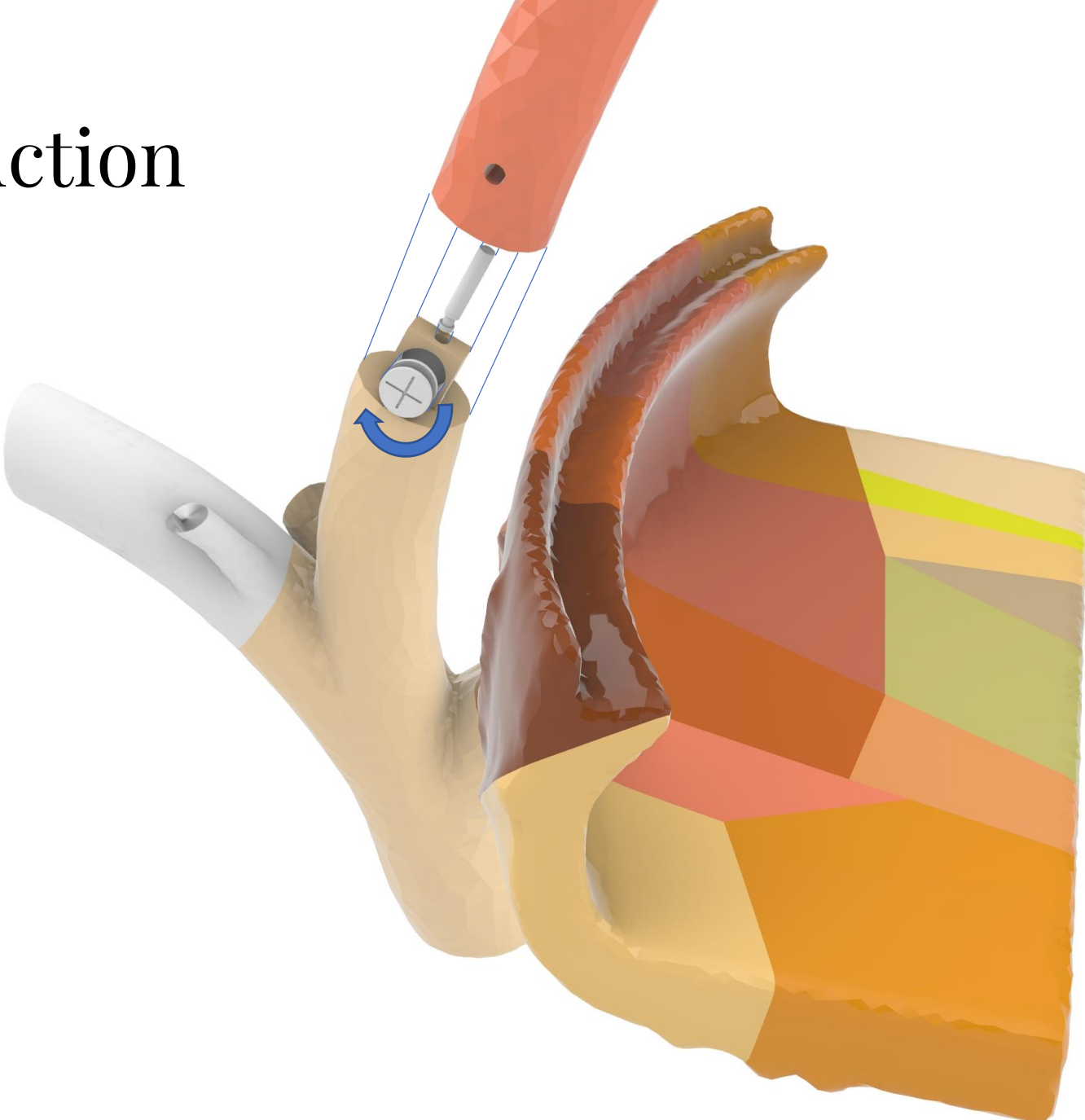

Mycelium construction

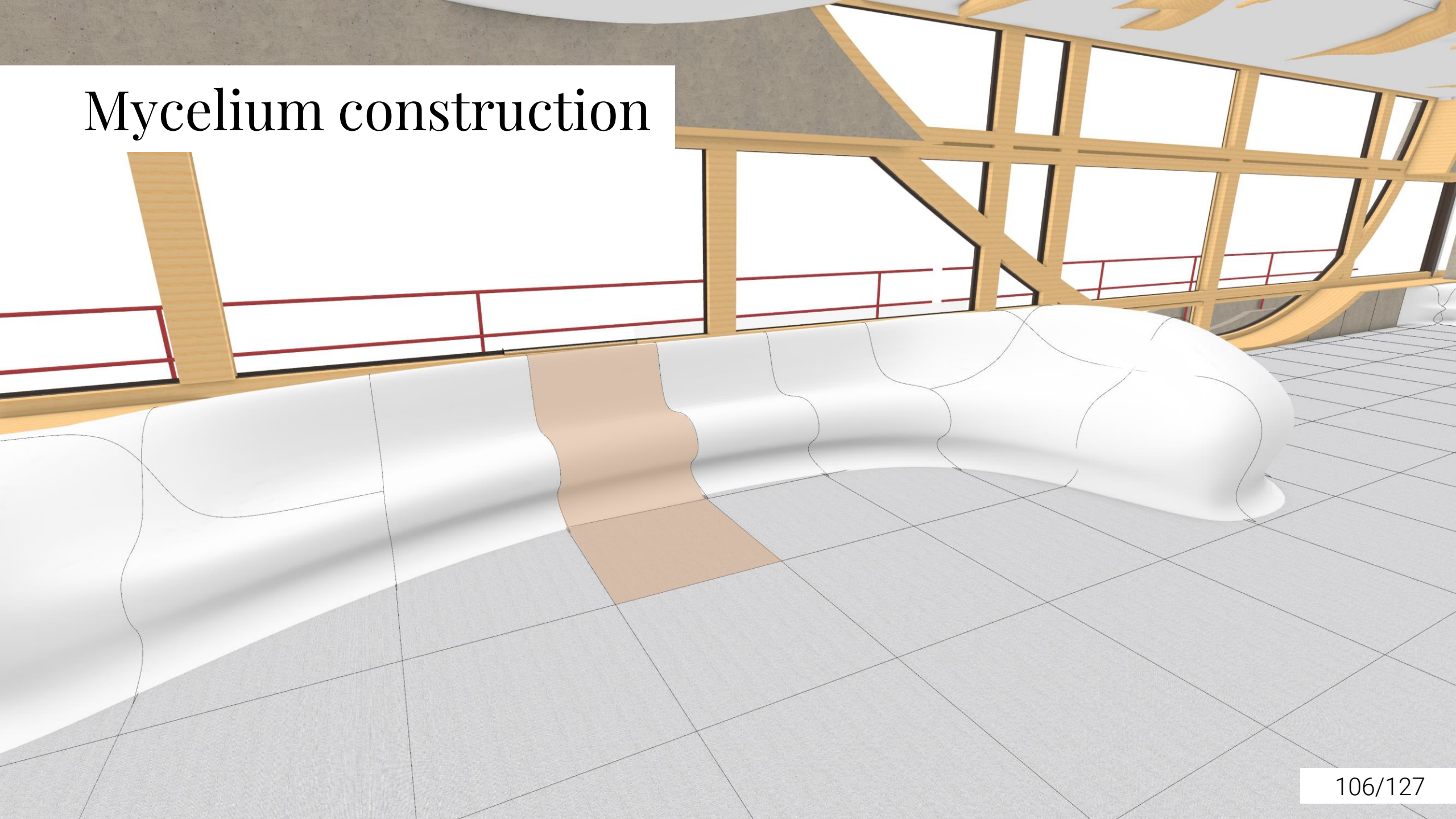

Mycelium construction

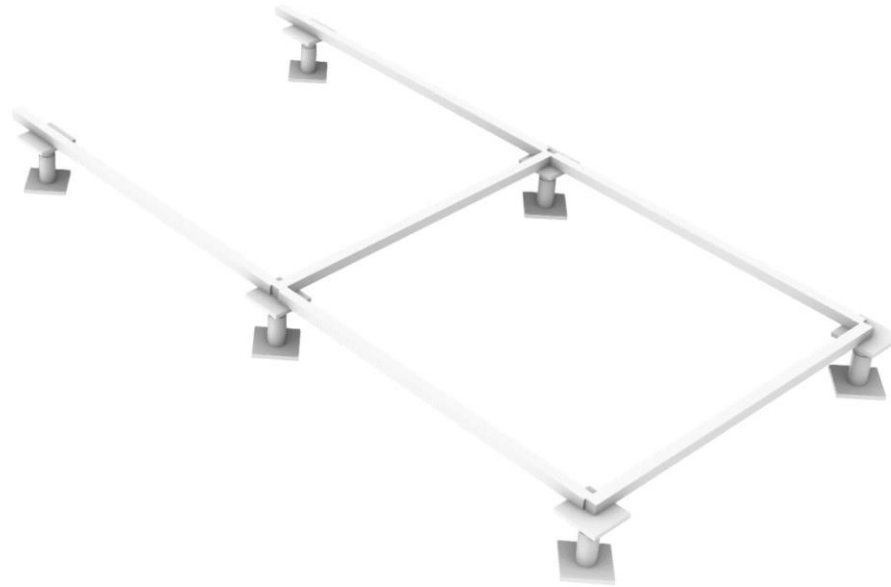
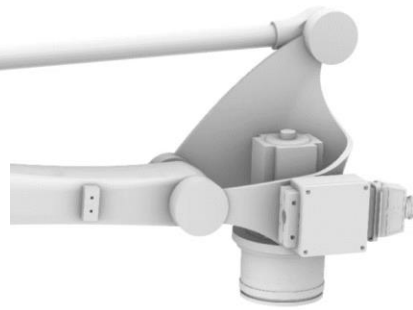

Mycelium construction

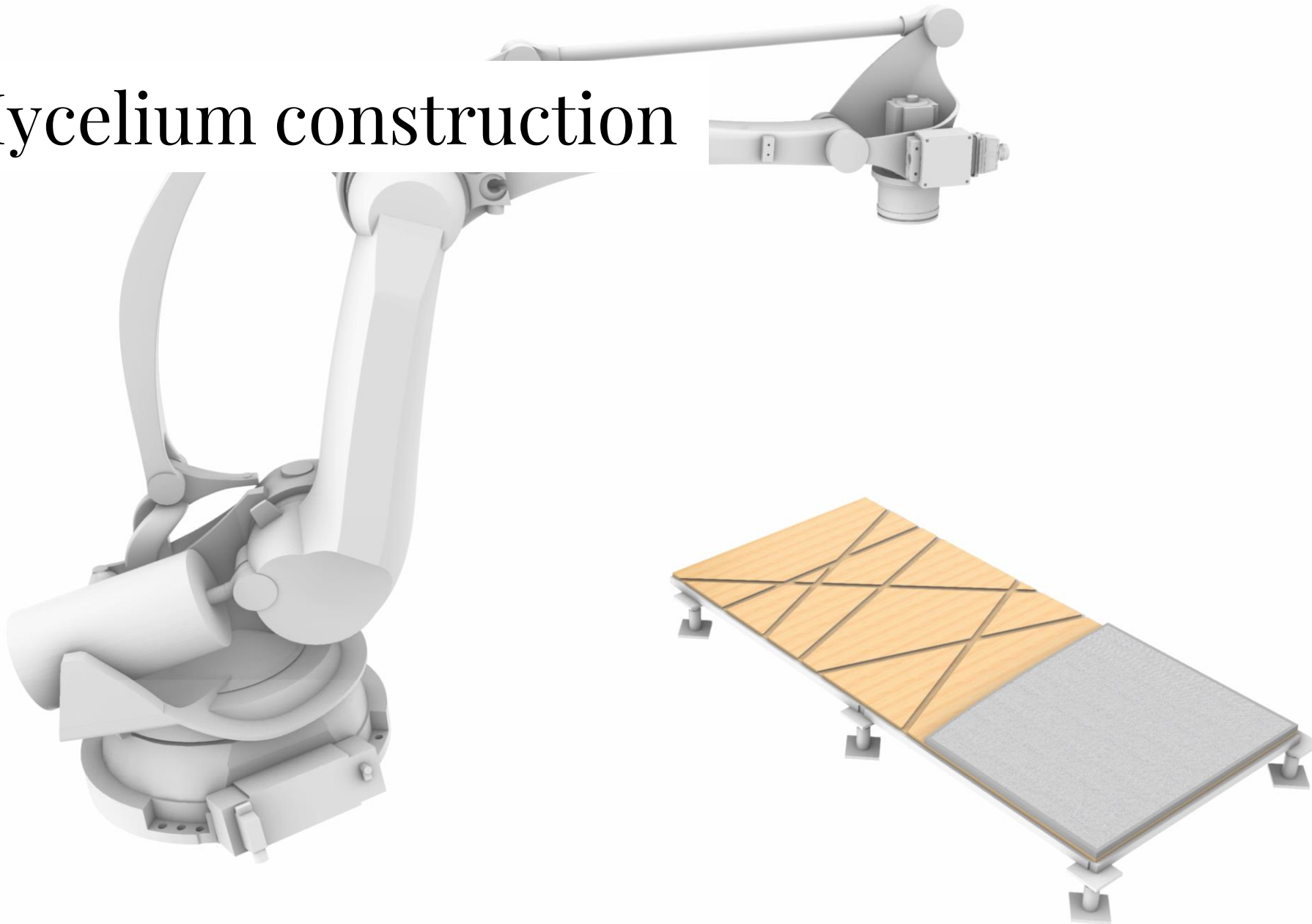

Mycelium construction

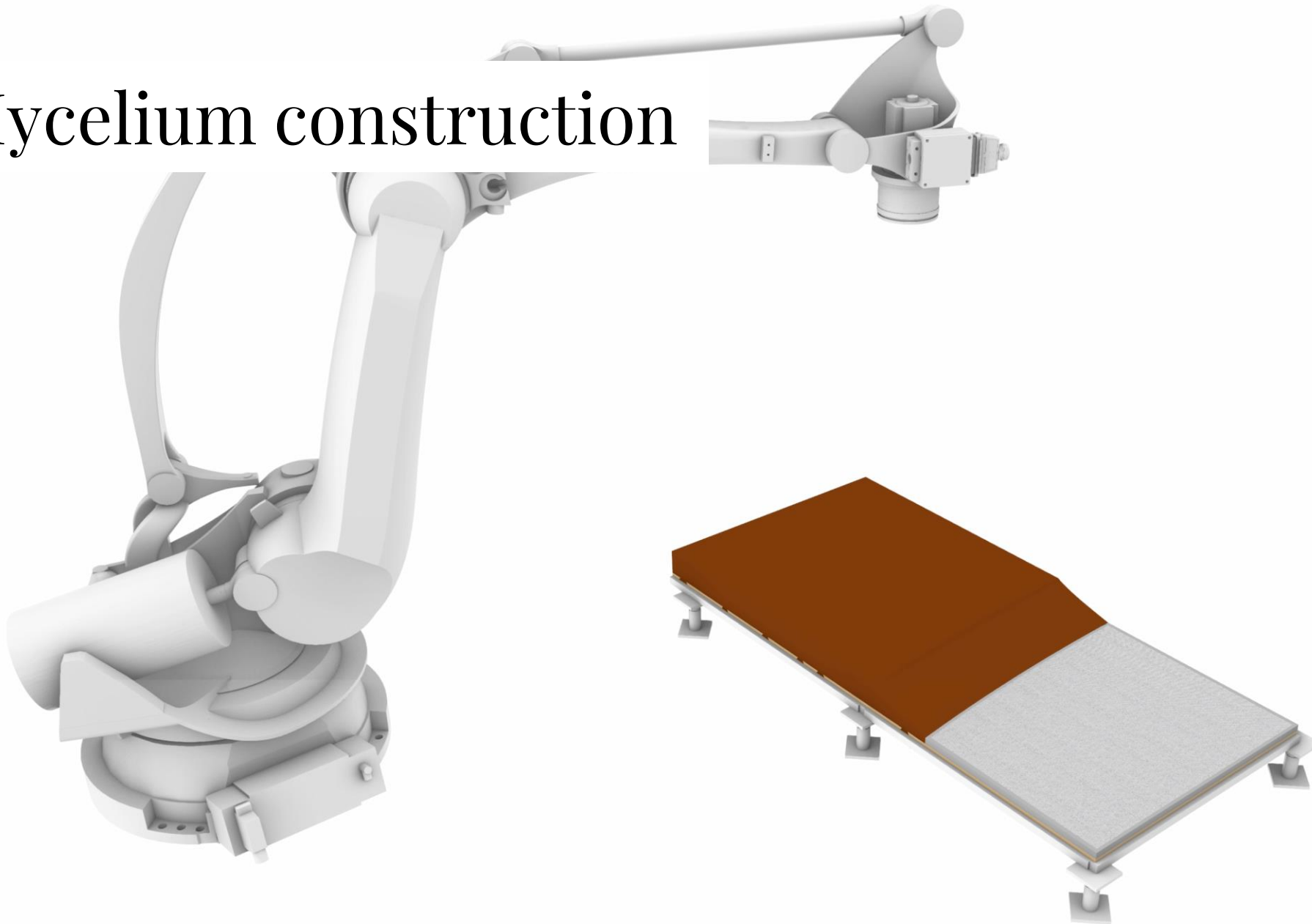

Mycelium construction

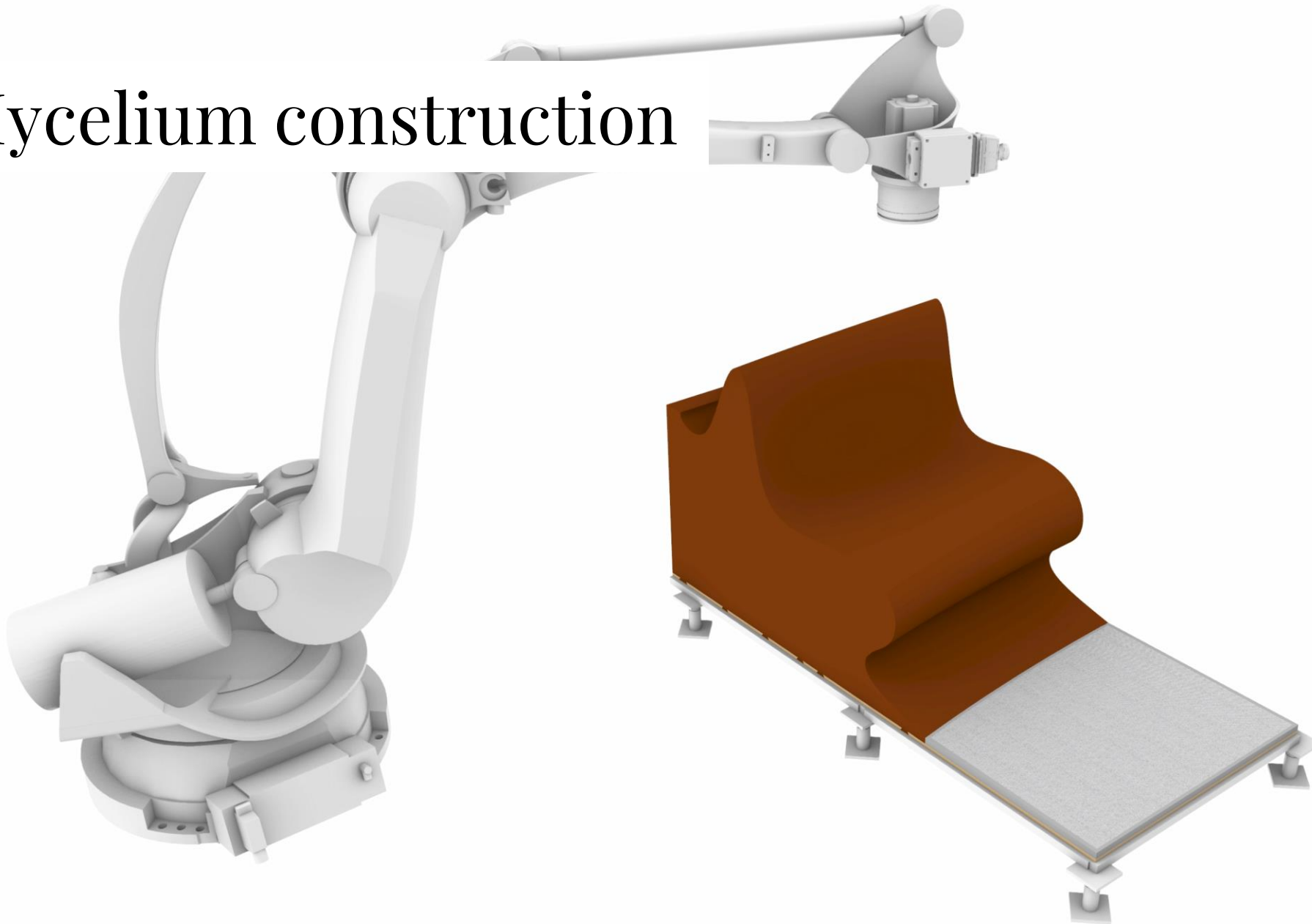

Mycelium construction

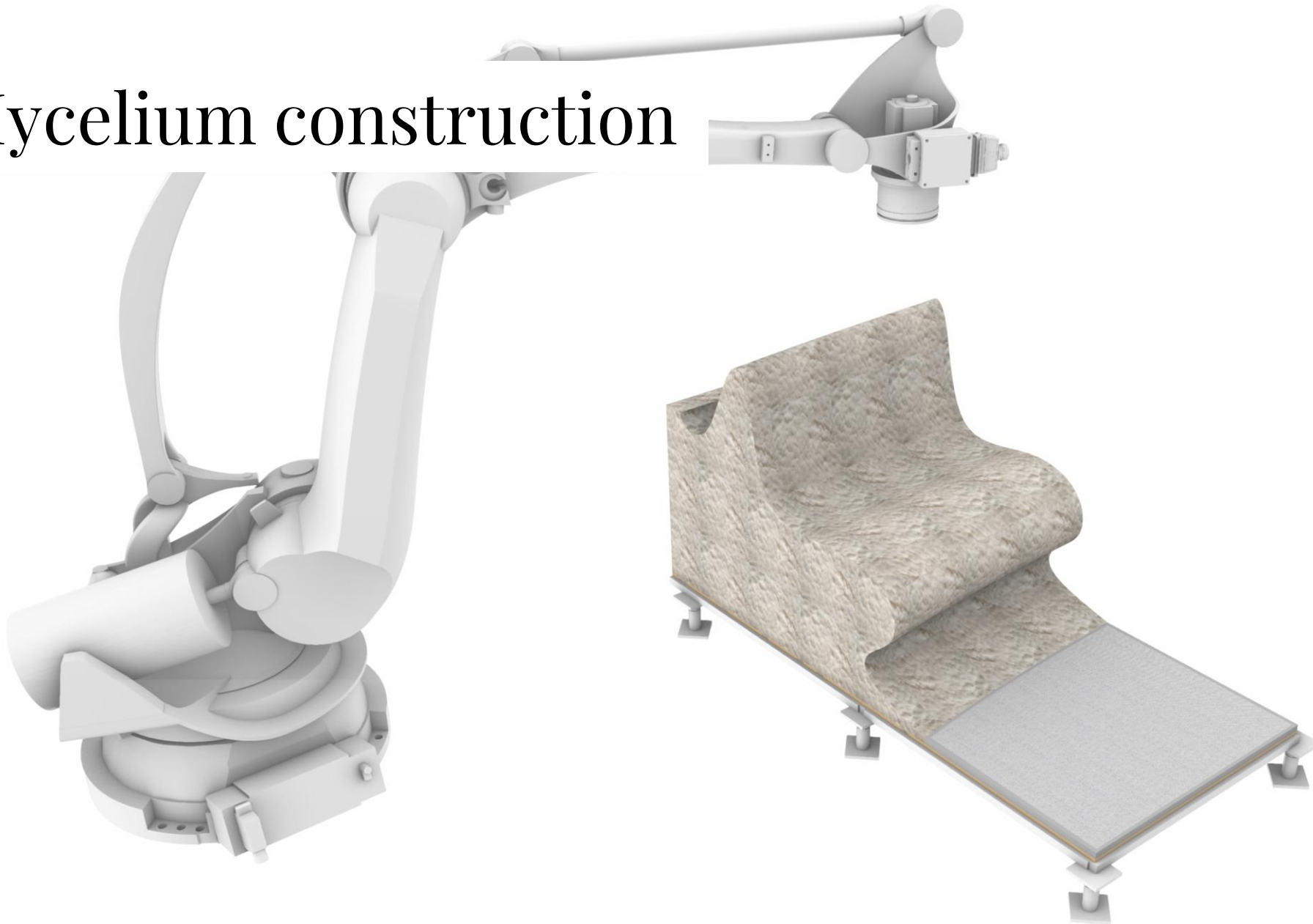

Additive and subtractive production



Additive and subtractive production

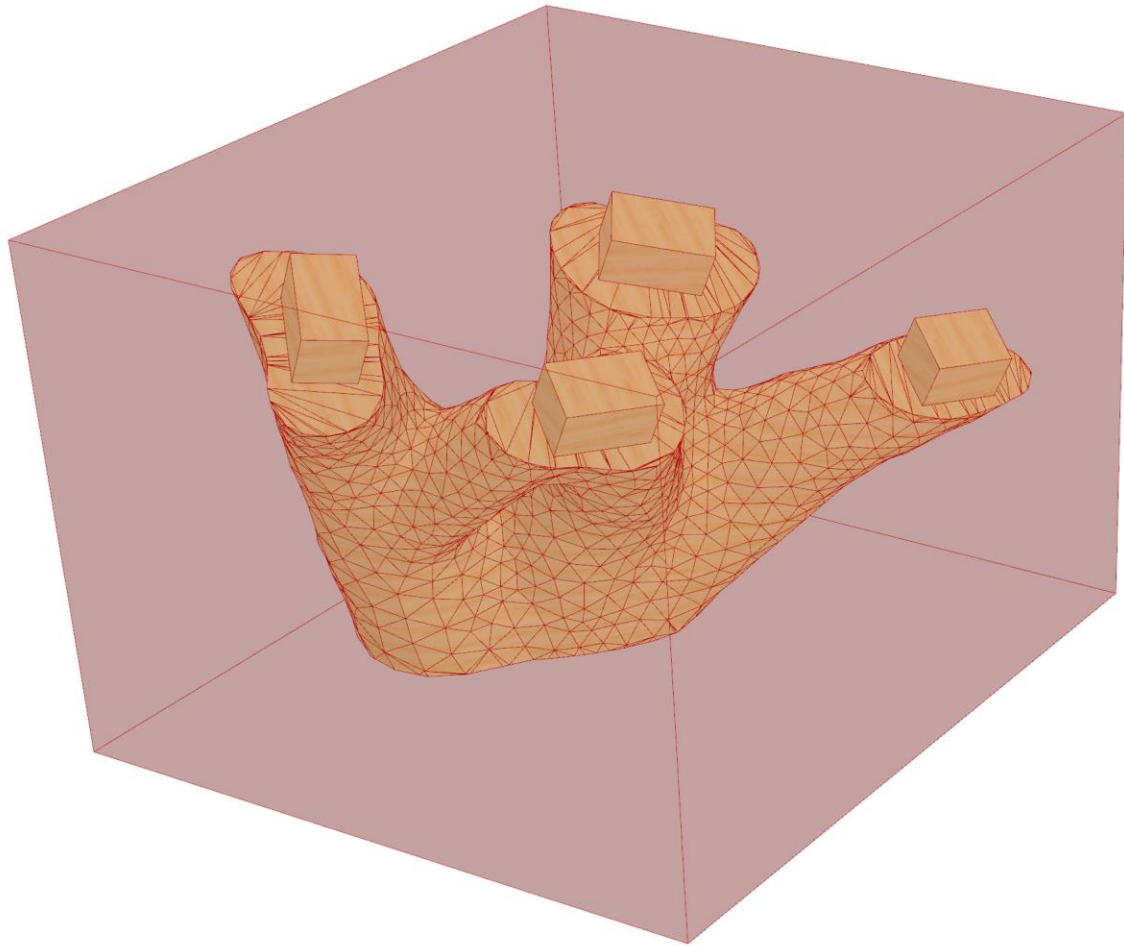

Additive and subtractive production

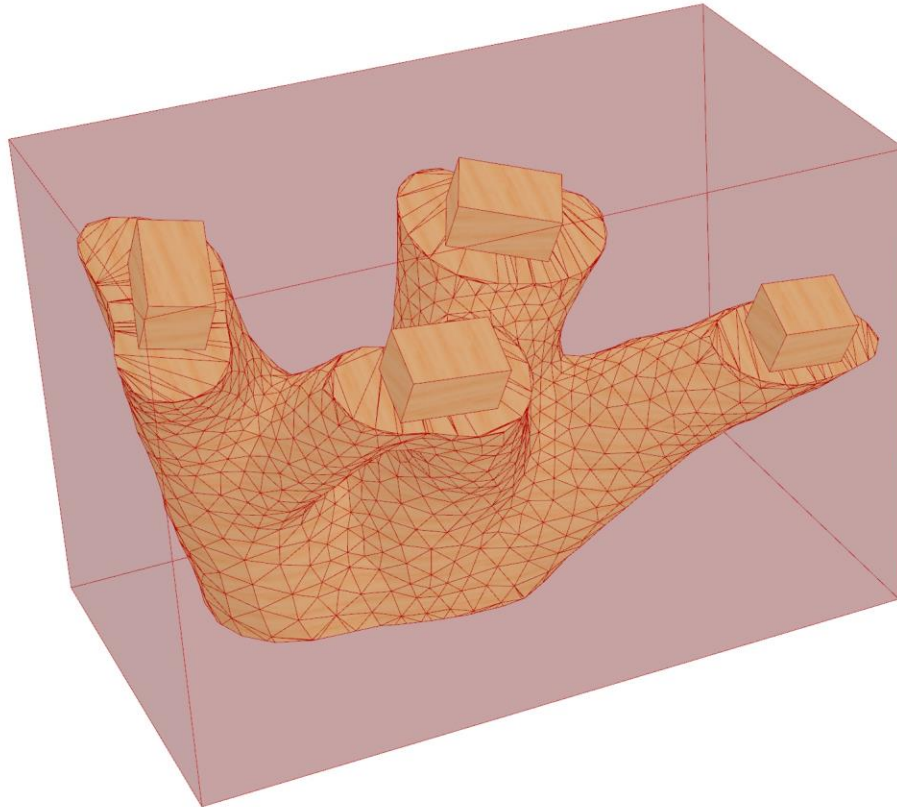

Mycelium

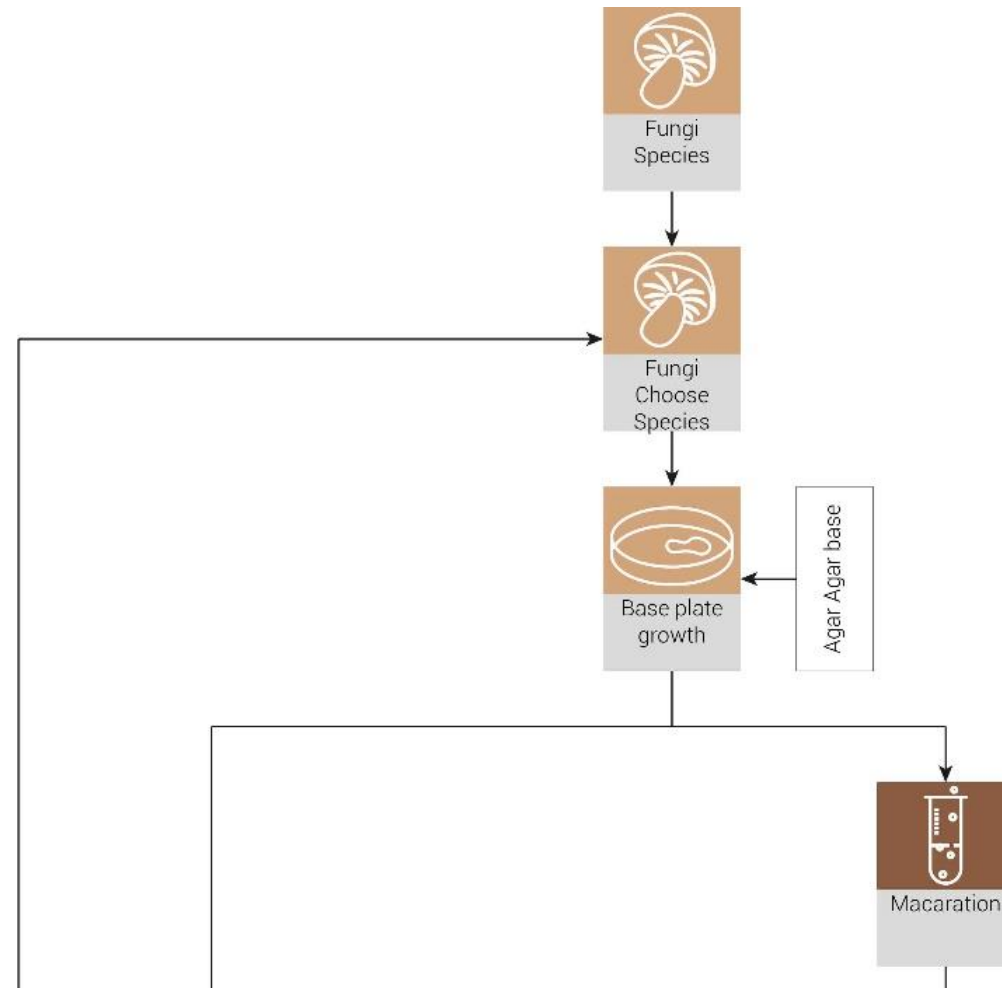

Material references



Construction strategy

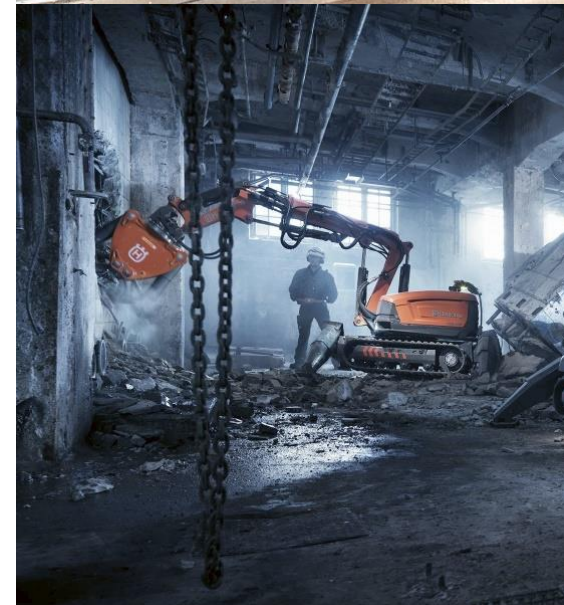
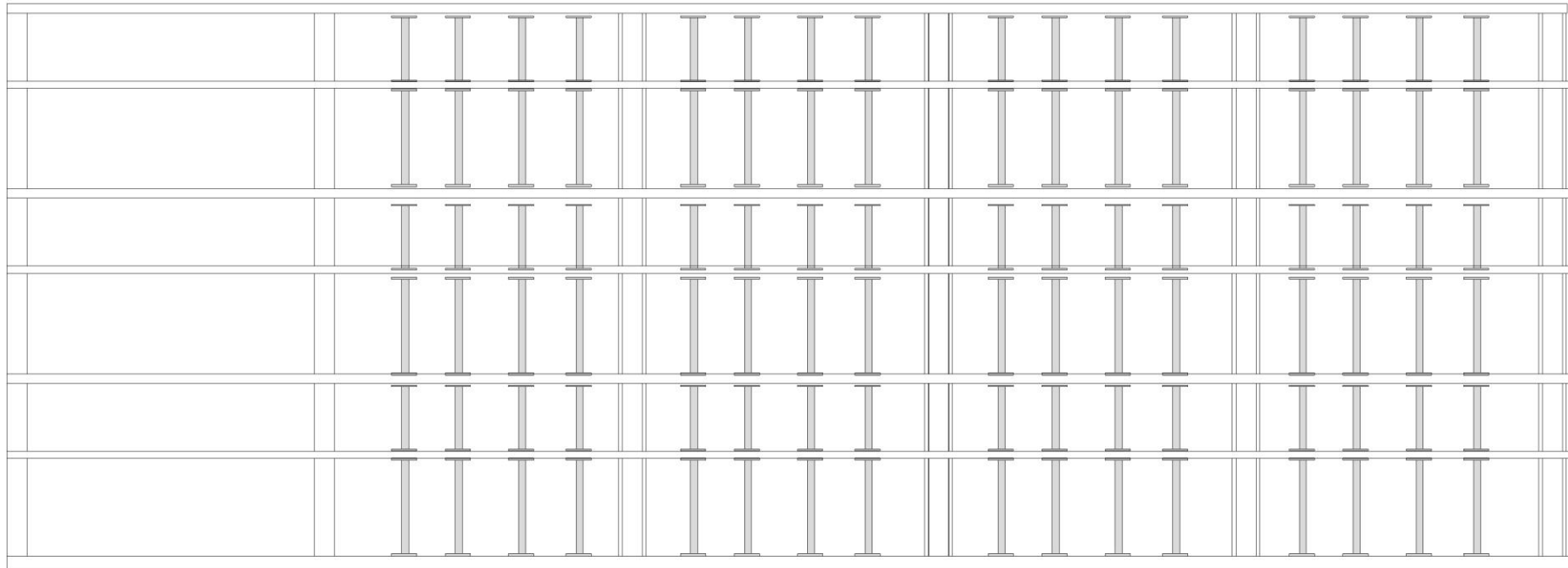

Construction strategy

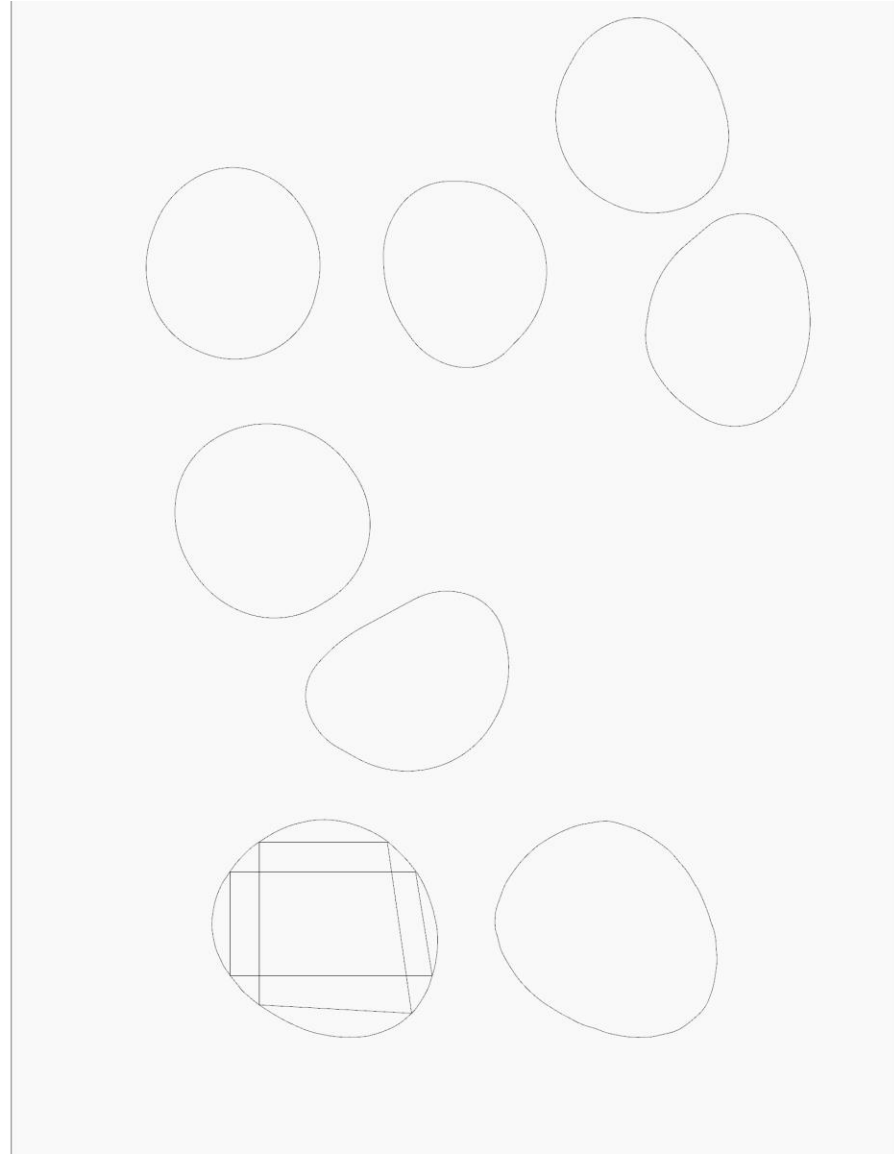

Construction strategy

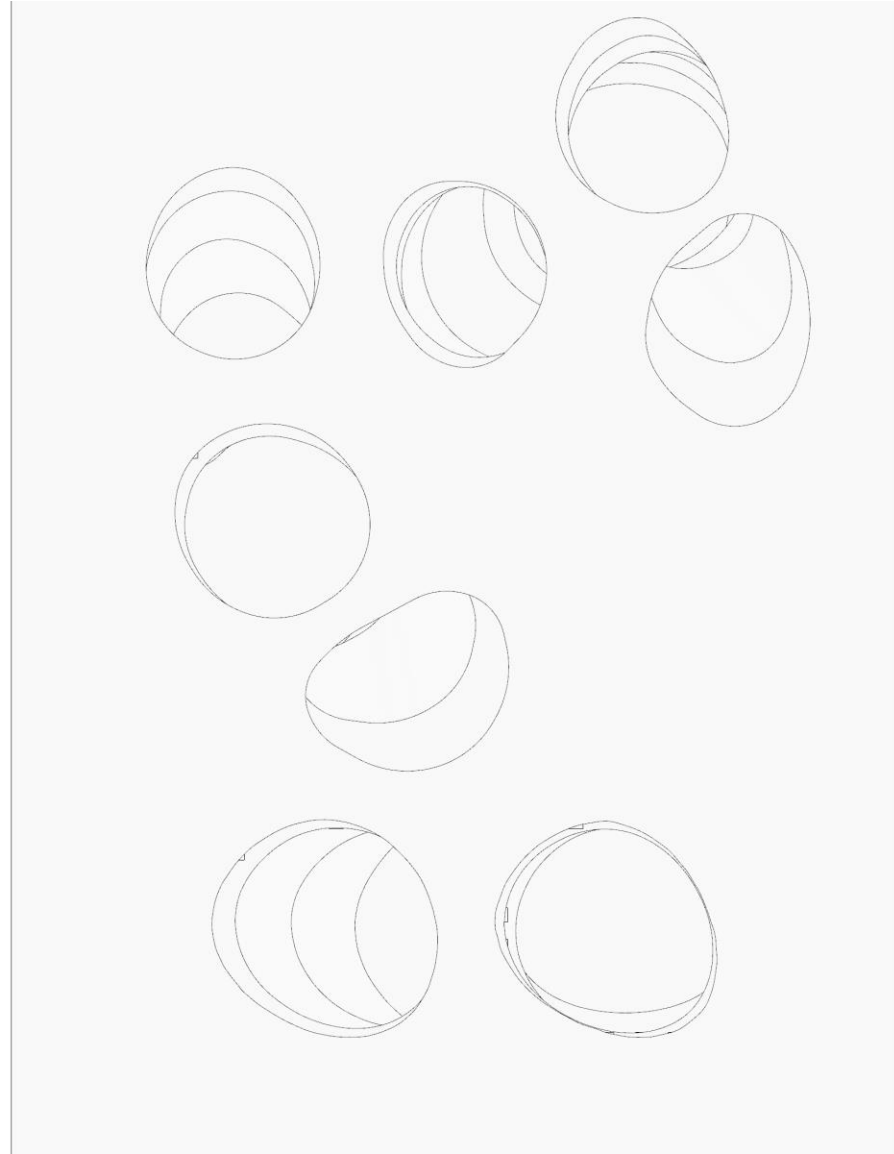

Construction strategy

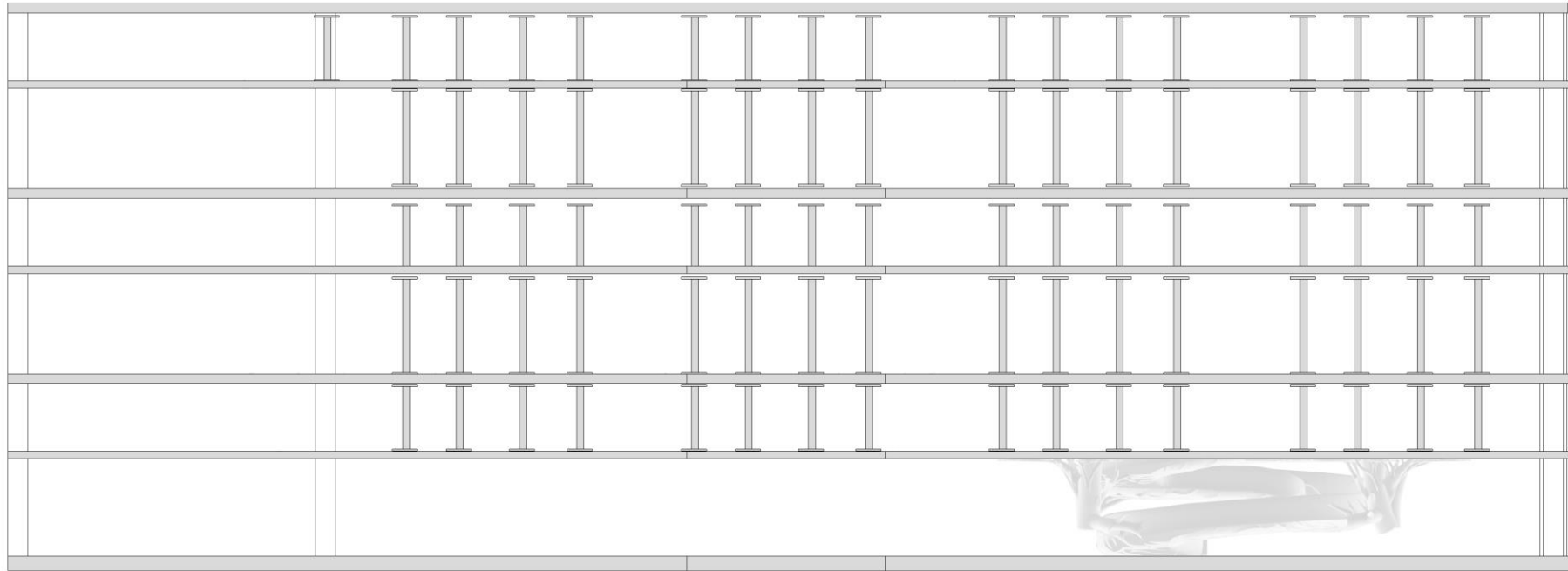

Construction strategy

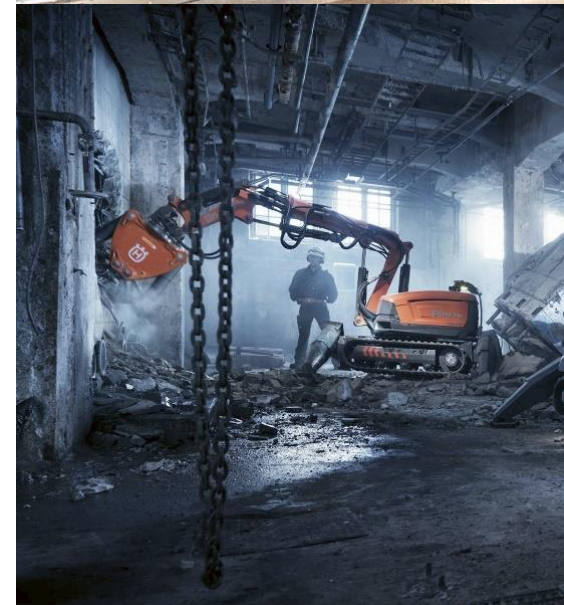
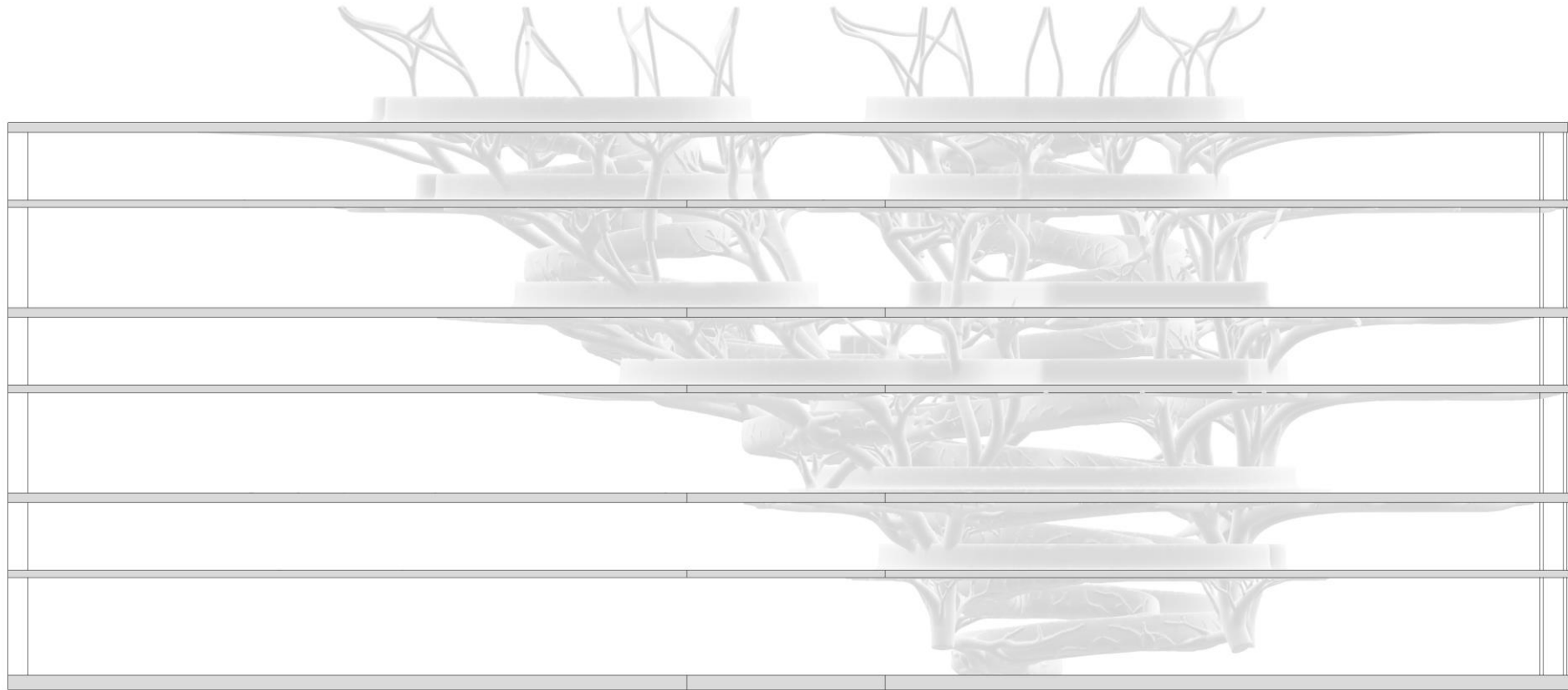

Impression





Impression

Impression

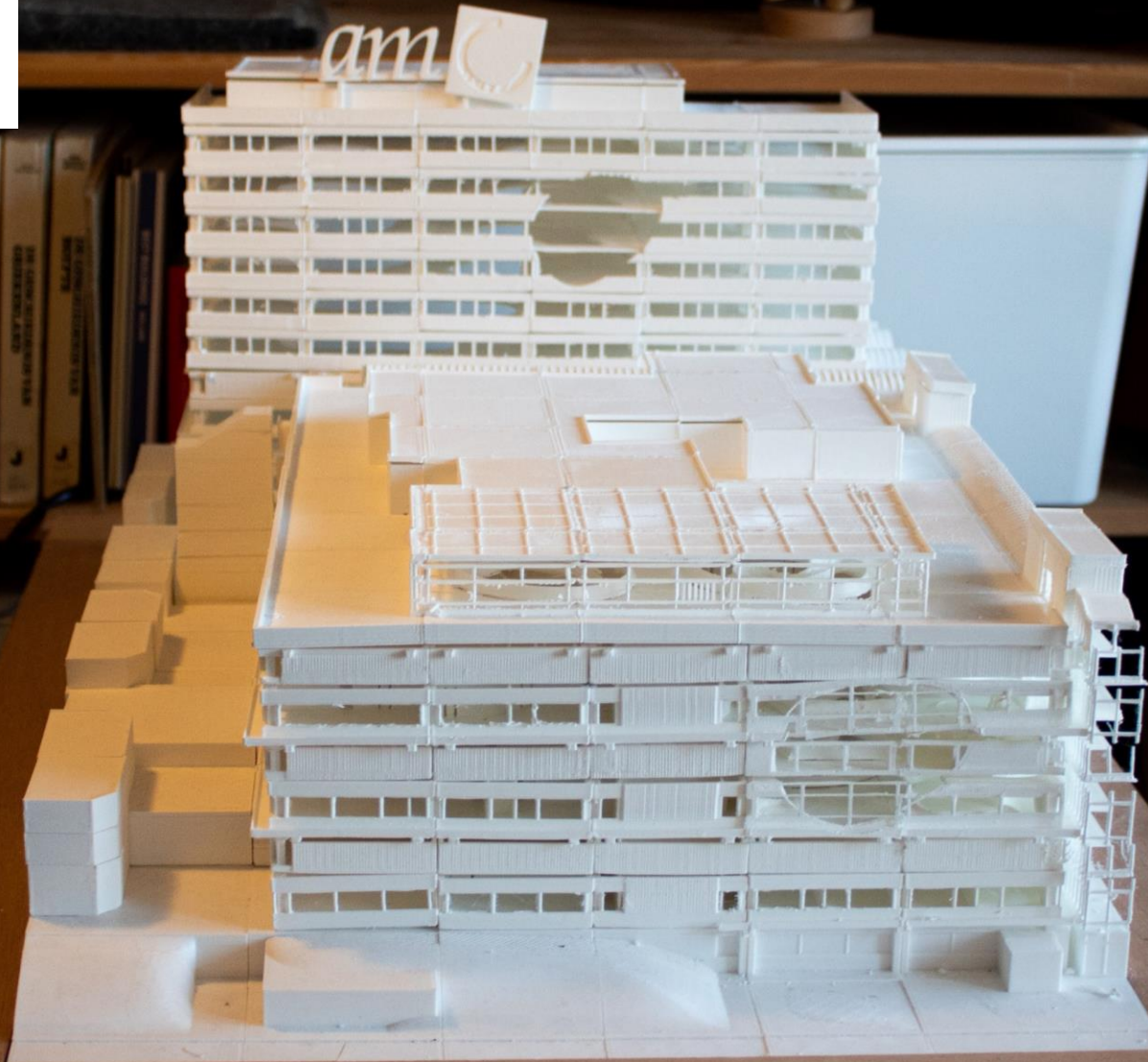

Impression



Impression

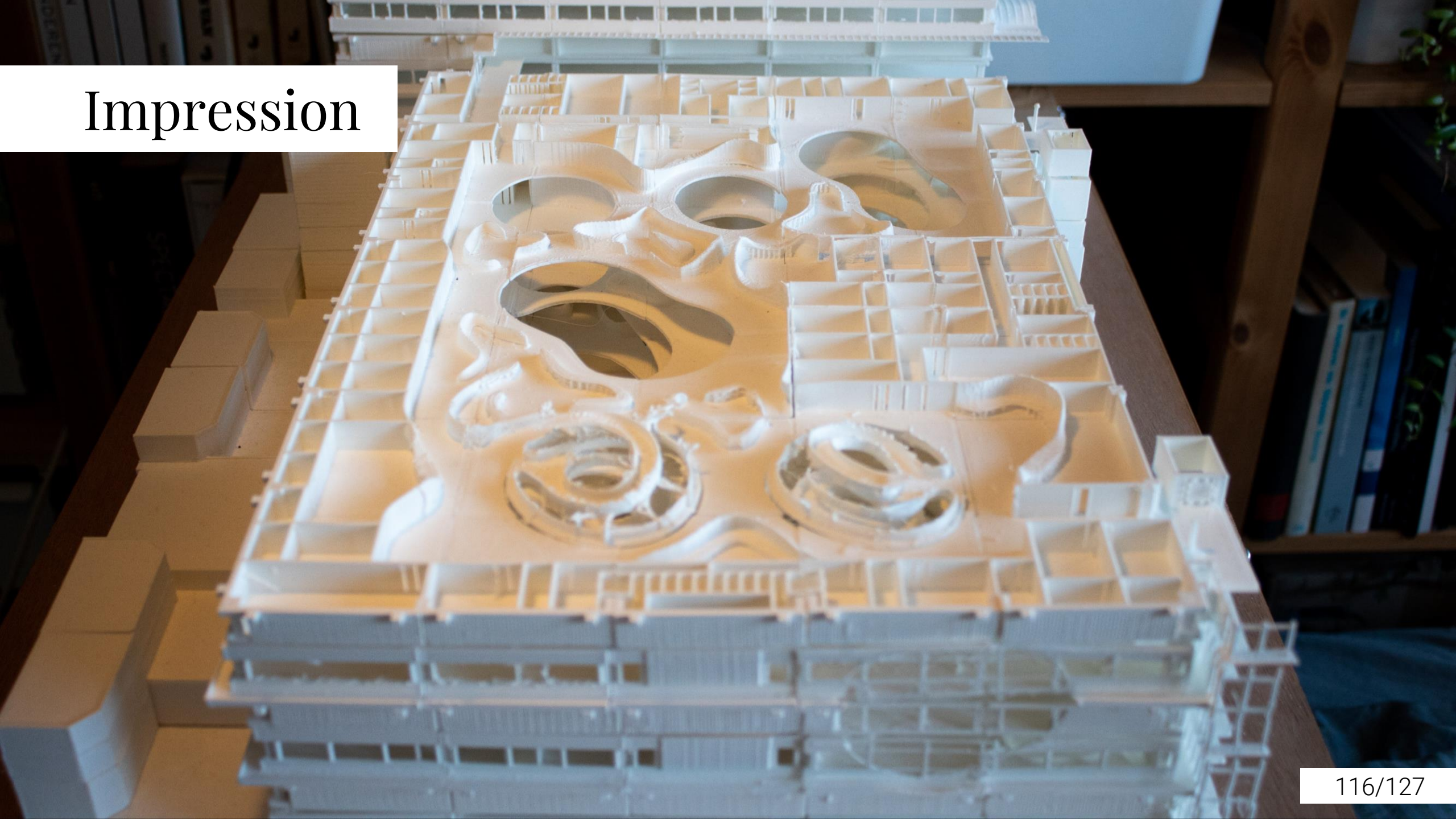

Impression

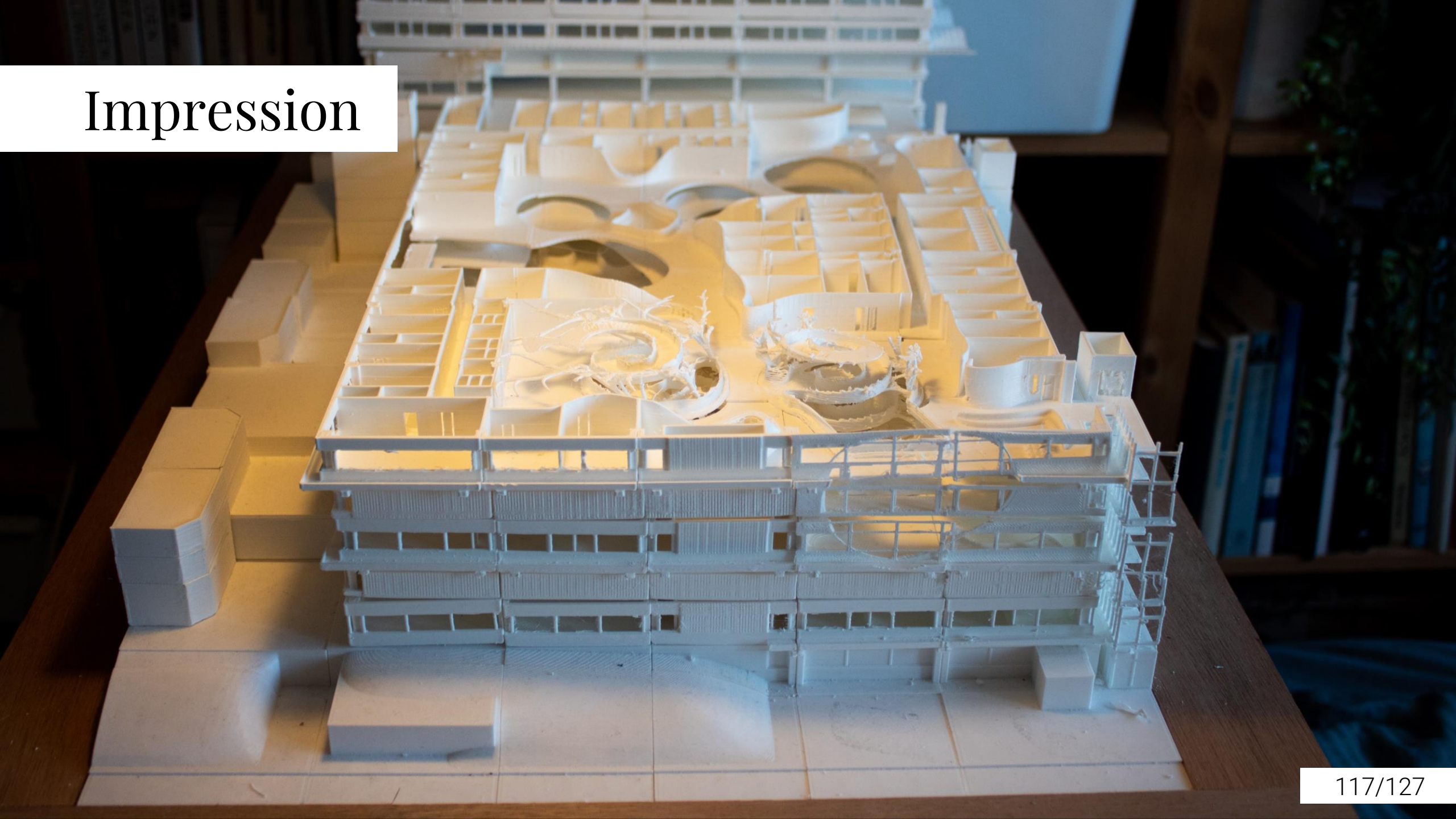

Impression

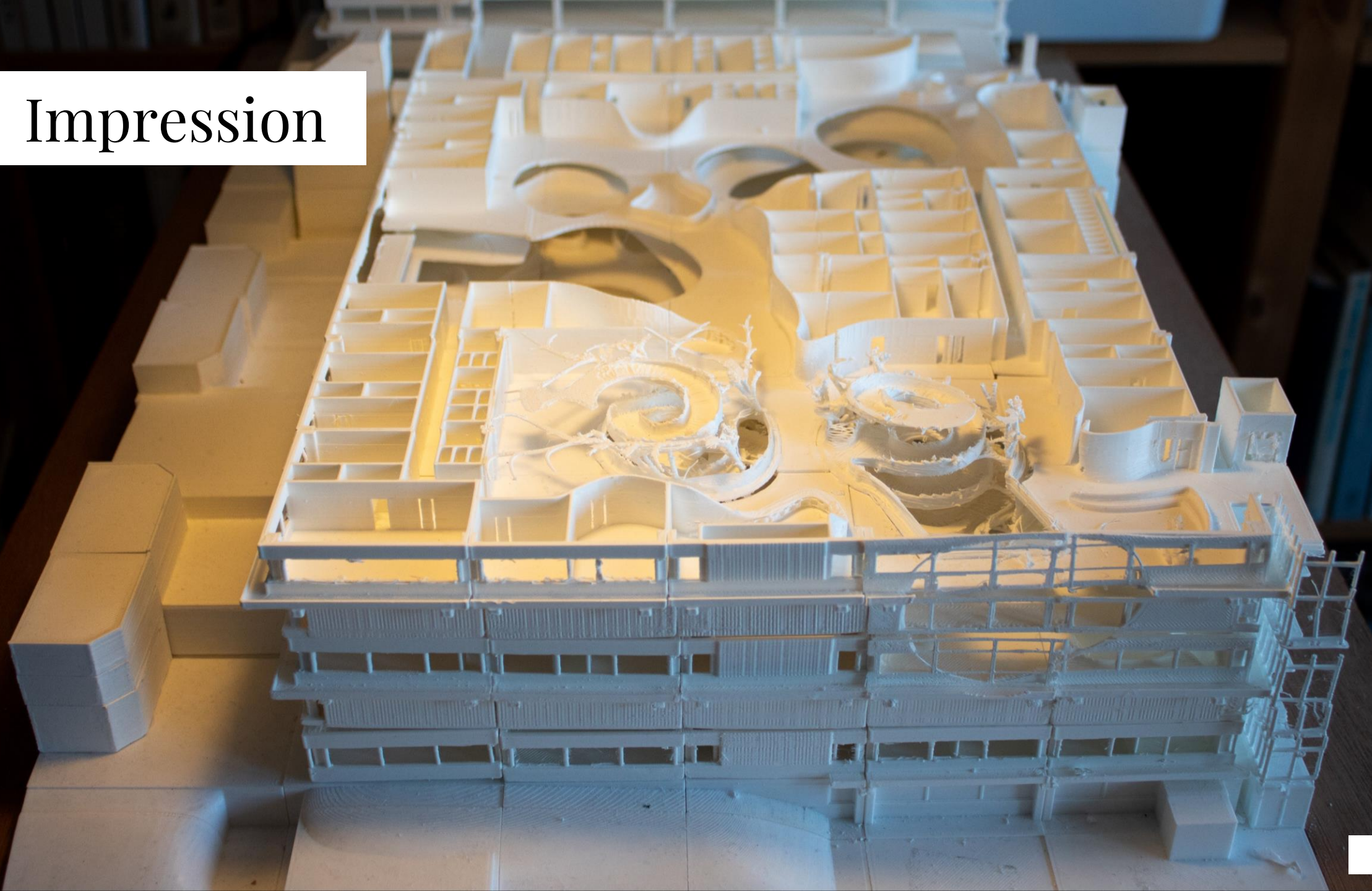

Impression



Impression

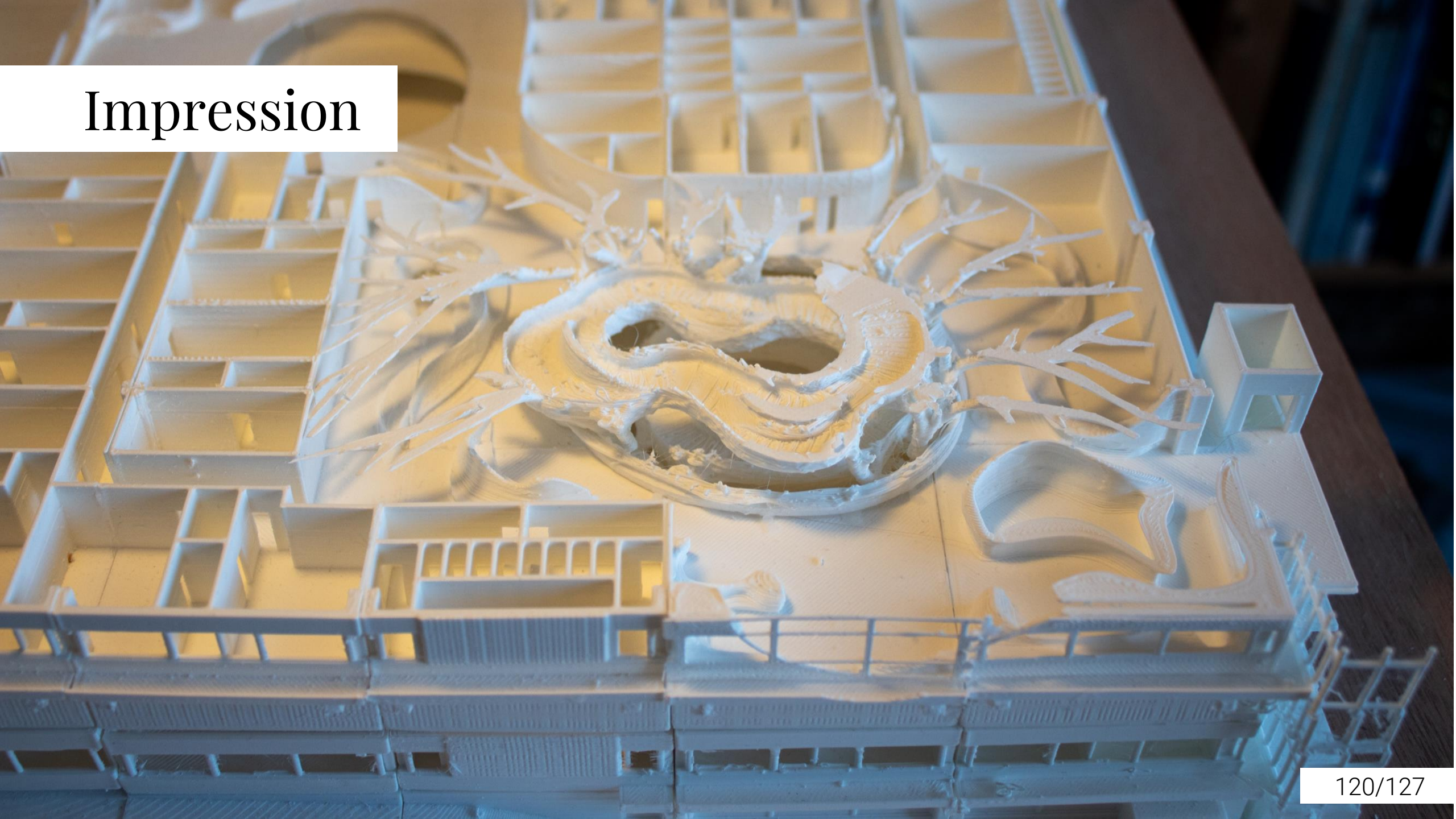

Impression

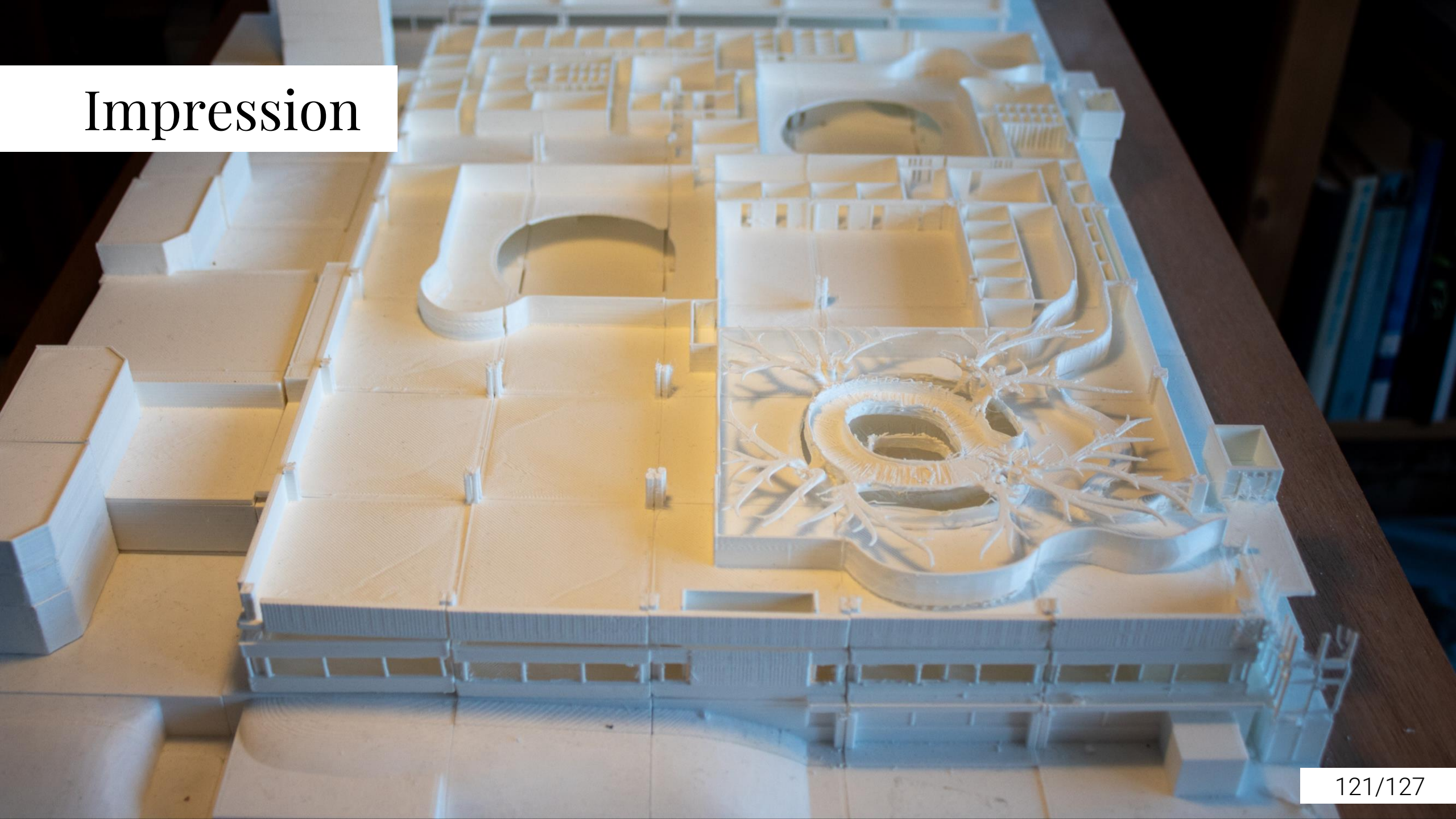

Impression

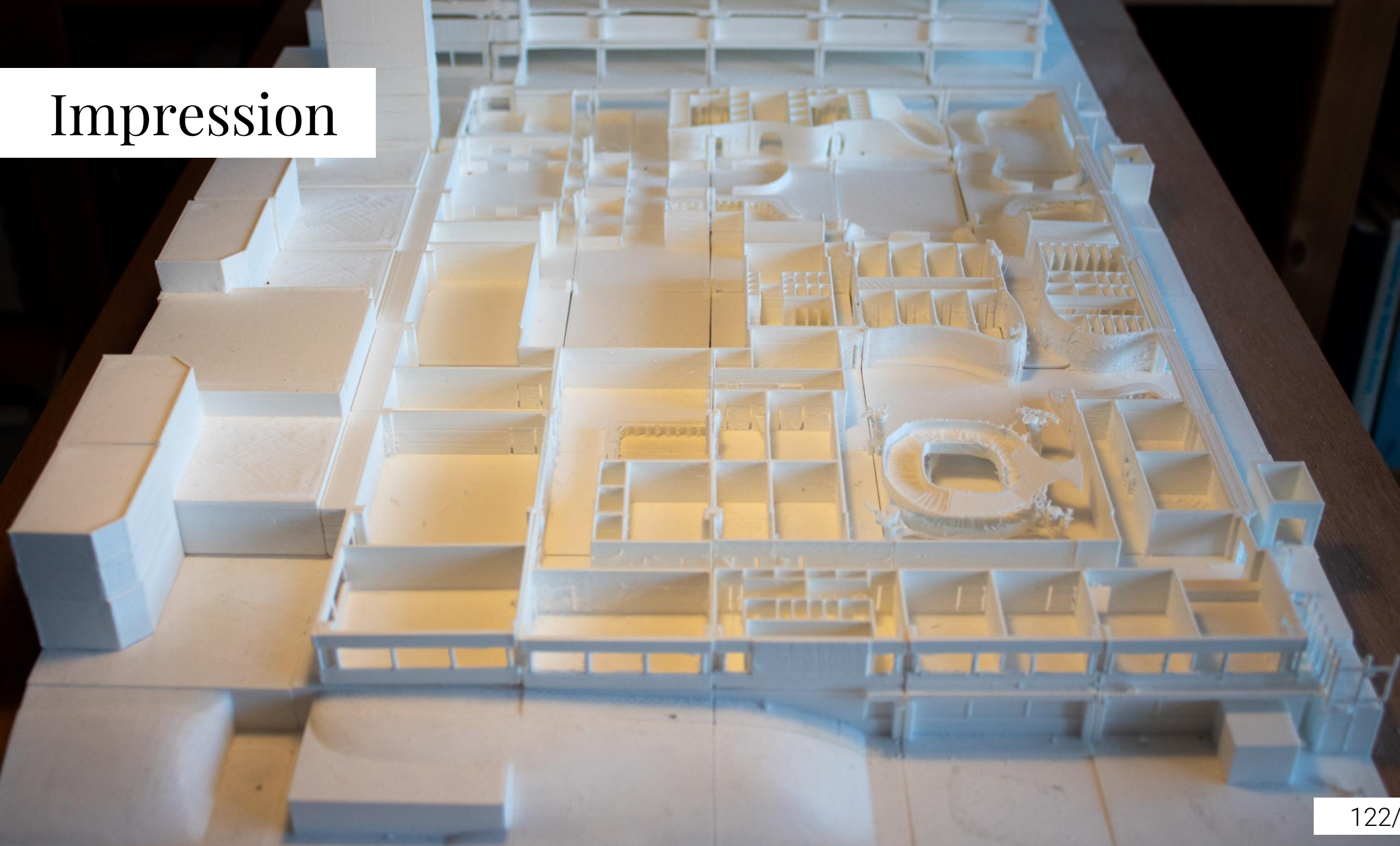

Impression

A close-up photograph of a white plastic grid with a yellowish glow emanating from behind it, possibly representing a data grid or a technical interface. The grid is composed of rectangular cells, and the glow is most intense in the upper-left quadrant. The overall image has a soft, slightly blurred quality, with the grid lines appearing as thin white lines against a darker, glowing background.

The research question

How to create an architectural intervention that functions as a healing environment within the existing structure of the AMC?

Conclusion

Through the cutting and removing of existing structure, my design has been able to nest itself in the void left by the removed construction. Providing an experiential pathway within the building inviting its users to move through and stay within the continuous public space. Through stimulus of vision, nature, exercise and daylight. The intervention results in space that contributes to the users' physical and psychological wellbeing;

An healing environment

Reflection

The AMC is a very interesting but complex structure. Something a one person team can barely get a grip on. While this provides the excitement of the challenge.

Through means of parametric design a interrelated and data driven design be created. As a result a design for this massive a building is much more a strategy what is possible than a fixed architecture outcome.

On the other hand this fascinating interrelated and data driven parametric aspect also provides the pitfall that a too complex and large amount of script results in too much change in the whole chain of different scripts and results in errors when the base is not as solid as one would like it to have.



The end