



- (51) International Patent Classification:
B03C 1/22 (2006.01)
- (21) International Application Number:
PCT/NL2010/050184
- (22) International Filing Date:
7 April 2010 (07.04.2010)
- (25) Filing Language: English
- (26) Publication Language: English
- (30) Priority Data:
2002736 9 April 2009 (09.04.2009) NL
- (71) Applicant (for all designated States except US): **TECHNISCHE UNIVERSITEIT DELFT** [NL/NL]; Stevinweg 1, NL-2628 CN Delft (NL).
- (72) Inventors; and
- (75) Inventors/Applicants (for US only): **REM, Peter Carlo** [NL/NL]; Jaagpad 5B, NL-2288 AB Rijswijk (NL). **BERKHOUT, Simon Peter Maria** [NL/NL]; Vlaardingsekade 36, NL-2636 BC Schipluiden (NL).
- (74) Agent: **VAN BREDA, Jacques**; Weteringschans 96, NL-1017 XS Amsterdam (NL).
- (81) Designated States (unless otherwise indicated, for every kind of national protection available): AE, AG, AL, AM,

AO, AT, AU, AZ, BA, BB, BG, BH, BR, BW, BY, BZ, CA, CH, CL, CN, CO, CR, CU, CZ, DE, DK, DM, DO, DZ, EC, EE, EG, ES, FI, GB, GD, GE, GH, GM, GT, HN, HR, HU, ID, IL, IN, IS, JP, KE, KG, KM, KN, KP, KR, KZ, LA, LC, LK, LR, LS, LT, LU, LY, MA, MD, ME, MG, MK, MN, MW, MX, MY, MZ, NA, NG, NI, NO, NZ, OM, PE, PG, PH, PL, PT, RO, RS, RU, SC, SD, SE, SG, SK, SL, SM, ST, SV, SY, TH, TJ, TM, TN, TR, TT, TZ, UA, UG, US, UZ, VC, VN, ZA, ZM, ZW.

- (84) Designated States (unless otherwise indicated, for every kind of regional protection available): ARIPO (BW, GH, GM, KE, LR, LS, MW, MZ, NA, SD, SL, SZ, TZ, UG, ZM, ZW), Eurasian (AM, AZ, BY, KG, KZ, MD, RU, TJ, TM), European (AT, BE, BG, CH, CY, CZ, DE, DK, EE, ES, FI, FR, GB, GR, HR, HU, IE, IS, IT, LT, LU, LV, MC, MK, MT, NL, NO, PL, PT, RO, SE, SI, SK, SM, TR), OAPI (BF, BJ, CF, CG, CI, CM, GA, GN, GQ, GW, ML, MR, NE, SN, TD, TG).

Published:

- with international search report (Art. 21(3))
- before the expiration of the time limit for amending the claims and to be republished in the event of receipt of amendments (Rule 48.2(h))

(54) Title: USE OF AN APPARATUS FOR SEPARATING MAGNETIC PIECES OF MATERIAL

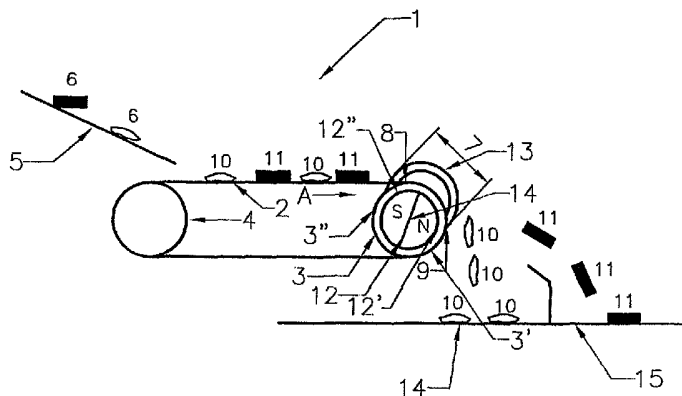

Fig. 1

(57) Abstract: Using of an apparatus for separating magnetic pieces of scrap-material of a first group from magnetic pieces of scrap-material of a second group, wherein a mixture of pieces of scrap-material from the first group and from the second group is collectively transported with a conveyor to a separating zone, in which separating zone the pieces or scrap-material are subjected to forces induced by a magnetic field and to gravitational forces.

Use of an apparatus for separating magnetic pieces of material

The invention relates to the use of an apparatus for separating magnetic pieces of scrap-material of a first group from magnetic pieces of scrap-material of a second group, wherein a mixture of pieces of scrap-material from the first group and from the second group is collectively transported with a conveyor to a separating zone, in which separating zone the pieces of scrap-material are subjected to forces induced by a magnetic field and to gravitational forces.

5 A method of separating magnetic pieces of scrap-material of a first group from magnetic pieces of scrap-material of a second group is known from US-B-6,364,117.

In the known method pieces of material, at least some of which are magnetic pieces, are separated from other pieces of material. In particular it is known from the prior art that iron sheets are separated from wasted iron products, which are parts of wasted electric products such as air-conditioners or refrigerators. In the prior art a mixture of sheet shaped scrap and ferrous cast blocks are transported by a moving conveyor and subjected to a magnetic force above the conveyor in order to recycle suitable iron pieces so as to be thrown into a furnace and recycled as cast material. The magnetic field provides an upwardly directed force to the magnetic pieces of material which is used to effect a separation between the sheet shaped scrap and the ferrous cast blocks. The separation is occasioned by the circumstance that the magnetic force applied on the sheet shaped scrap is stronger than the force on the same weight cast block.

20 Although it is possible according to US-B-6,364,117 to separate different pieces of magnetic material from each other, it is still required that the first group of magnetic pieces of material distinguishes strongly from the second group of magnetic pieces of material so as to be able to effect a reliable separation. Notably sheet shaped scraps have quite different characteristics than ferrous cast blocks, in view of which it is possible to separate them from each other.

35 EP-A-1 878 505 discloses an apparatus having a separating zone for separating magnetic pieces of scrap-material of a first group from magnetic pieces of scrap-material of a second group, which apparatus further comprises a conveyor for transporting a mixture of said pieces of scrap-material from the

first group and from the second group to the separating zone, at which separating zone the mixture of pieces of scrap material is subjected to a magnetic field and wherein at the separation zone the conveyor is supported by a drum around which the conveyor
5 passes at a pre-defined speed so as to impart on the mixture of magnetic pieces of scrap-material a pre-defined horizontal velocity at which said pieces are released from the conveyor at said separating zone so as to subject the pieces of scrap-
10 material to forces induced by the magnetic field and to gravitational forces. The mixture of scrap-material concerns a first group of liberated scrap, that means fragments which essentially do not contain materials other than iron and steel, and a second group of non-liberated scrap, that means fragments that do also contain other materials, in particular copper.

15 It is an object of the invention to enable a separation of a first group of magnetic pieces of material from a second group of magnetic pieces of material in which the characterizing features of the material from the first group do not have to distinguish significantly from the features of the magnetic
20 pieces of material from the second group. It is thus an object of the invention to make it possible to separate magnetic pieces of material that are only moderately distinguishable from each other.

25 An other object of the invention is to provide a viable alternative for the method known from US-B-6,364,117.

30 Still another object of the invention is to be able to provide separate groups of material which can then also be separately applied in an electrical melting furnace for steel. Practice learns that this is beneficial for the steel melting process in such a furnace.

The objects of the invention are promoted by the features of one or more of the appended claims.

35 In a first aspect of the invention the apparatus known from EP-A-1 878 505 is used for separating magnetic pieces of scrap-material of a first group from magnetic pieces of scrap-material of a second group, wherein the first group of material concerns ferrous scrap with a bulk-density of less than 900 kg/m^3 and the second group of material concerns ferrous scrap with a bulk-density of more than 900 kg/m^3 .

Surprisingly it has been found that by using the known apparatus according to the invention reliably distinct paraboles are obtained that are characteristic for the respective first group of materials and second group of materials, enabling to
5 reliably separate ferrous scrap with a bulk-density of less than 900 kg/m³ from ferrous scrap with a bulk-density of more than 900 kg/m³.

In a further aspect of the invention the forces induced by the magnetic field on the magnetic pieces of scrap-material
10 in the separation zone are constantly and without alternating component attracting said magnetic pieces of scrap-material towards the drum.

It is remarked that US-A-4,781,821 discloses a process for separating magnetic particles from non-magnetic particles
15 using a short belt magnetic separator having a pulley head with axial pole permanent magnets located within said pulley head. This known apparatus is used in a method in which weakly magnetic material is separated from strongly magnetic material. It concerns, however, in the method according to US-A-4,781,821 a
20 separation process for ore particles which is neither intended nor suitable for separating a mixture of pieces of scrap-material, all having magnetic properties. Moreover in the method disclosed in US-A-4,781,821 a plurality of axial pole magnets is used with alternating poles near to the drum-surface causing
25 that there is no constant attracting magnetic force that is aimed towards the drum, when hypothetically speaking this known method would be used for separating scrap-material. The inventors have found that it is particularly the constant attracting magnetic force without alternating component that acts on the
30 magnetic pieces of scrap-material that contributes in effecting a reliable separation of different pieces of scrap-material that exhibit only modestly differentiating parameters.

In order to realise that the forces induced by the magnetic field in the separate zone on the magnetic pieces of
35 scrap-material is constant and without alternating component, it is desirable that the magnetic field lines in the separation zone are unidirectional. This way all magnetic field lines commonly work on the magnetic pieces of scrap-material to attract this material towards the drum.

40 It has further been found advantageous that the magnetic field has magnetic field lines that collectively span the entire

separation zone and that the magnetic field lines share a departure area and arrival area respectively on the drum, which departure area and arrival area are on distinct halves of said drum. This secures that the forces that act on the magnetic
5 pieces of scrap-material whilst said material is conveyed through the separation zone gradually increase to a pre-defined constant value, and decline again when the pieces of scrap material are released from the conveyor due to their forward velocity as imparted on the material by the conveyor.

10 A suitable way to implement the desirable features of the magnetic field lines in the separation zone is by having the magnetic field induced by a single magnet placed in the drum.

It is preferred then that the magnetic field is induced by a single dipole magnet having a plane separating a north-pole
15 from a south-pole of said magnet that is at a 45°-angle with respect to the horizon.

In order to effect an adequate separation in the separation zone without sacrificing throughput, it is preferable that the conveyor moves at a pre-defined speed of at least 2,5 m/s,
20 and preferably at least 3 m/s. In connection therewith it is further desirable that the magnetic field has a strength selected in dependence of the conveyor speed, preferably approximately 0,15 Tesla at a belt speed of 3-3,5 m/s.

Another aspect of the invention concerns a method of
25 making steel in an electrical melting furnace, comprising the step of introducing scrap-material into the furnace making use of the separate groups of material that are obtained by using the known apparatus in the above explained manner according to the invention. This steel making process can now be beneficially
30 executed such that the scrap-material is introduced into the furnace in sets of layers whereby for every set of two layers a first layer concerns ferrous scrap of a first group of material with a bulk-density of less than 900 kg/m³, and a second layer which is placed on top of the first layer and concerns ferrous
35 scrap of a second group of material with a bulk-density of more than 900 kg/m³. This promotes an effective processing of the group of material having the lower bulk-density of less than 900 kg/m³.

The invention will hereinafter be further elucidated
40 with reference to the drawing of an exemplary embodiment of an apparatus that is used in accordance with the invention.

In the drawing a single Fig. 1 shows an apparatus 1 embodied with a conveyor belt 2 that moves at a pre-defined speed, for instance at least 2,5 m/s, and preferably at least 3 m/s in the direction of arrow A.

5 The conveyor belt 2 moves around drums 3, 4 and thus constitutes an endless conveyor belt.

The apparatus 1 further has a feed trough 5 for bringing pieces of scrap-material 6 onto the conveyor belt 2. As mentioned the conveyor belt 2 moves in the direction A towards drum 10 3, at which drum 3 a separation zone 7 is present. The entry section of the separation zone 7 is indicated with reference numeral 8, whereas the exit section of the separation zone is indicated with reference numeral 9.

15 Due to the movement speed of the conveyor belt 2 in the direction A, a pre-defined horizontal velocity is imparted on the pieces of scrap-material 10 and 11 respectively upon their release from the conveyor 2.

In the drum 3 that supports the conveyor belt 2, a magnet 12 is placed inducing magnetic field lines 13 in the separation zone 7 which inflict magnetic forces on the pieces of 20 scrap-material 10, 11. These forces in combination with the forces due to gravity and the horizontal velocity imparted on the pieces of scrap-material 10, 11 by the movement of the conveyor belt 2 cause a separation between the pieces of scrap- 25 material 10 forming part of a first group and the pieces of scrap-material 11 forming part of a second group.

It has been found that it is possible to reliably separate pieces of scrap-material 10 forming part of the first group that avail of a bulk-density of less than 900 kg/m^3 , and that the 30 pieces of scrap material 11 forming part of the second group may avail of a bulk-density of more than 900 kg/m^3 . The figure shows that the scrap-material 10 of the first group assumes a parabole upon release from the conveyor causing it to be collected in an area 14 close to the drum 3. The scrap-material 11 of the second 35 group on the other hand gets collected in an area 15 more distant from the drum 3 than area 14 due to the differentiating parabole that the scrap-material 11 assumes upon release from the conveyor 2.

40 In order to effect a reliable separation with such only modestly distinguishing parameters between the pieces of scrap-material 10 of the first group and the pieces of scrap-material

11 of the second group, it is preferable that the forces induced by the magnetic field lines 13 in the separation zone 7 are constantly and without alternating component attracting the magnetic pieces of scrap-material 10, 11 towards the drum 3. As the figure shows in connection with this requirement it is beneficial that the magnetic field lines 13 in the separation zone 7 are unidirectional.

The figure further shows that the magnetic field lines 13 collectively span the entire separation zone 7 and even go beyond the entry section 8 and exit section 9. Further the said magnetic field lines 13 share a departure area 12' and arrival area 12'' respectively which are on distinct halves 3' and 3'' of the drum 3.

The figure shows the preferred embodiment in which there is a single dipole magnet 12 having a plane 14 that separates a north pole N from a south pole S of said magnet 12 and that this plane 14 is at a 45°-angle with respect to the horizon.

The strength of the magnetic fields is preferably selected in dependence of the movement-speed of the conveyor belt 2 and amounts preferably approximately 0,15 Tesla at a belt speed of 3-3,5 m/s.

Example

The apparatus as discussed hereinabove with reference to figure 1 was used to separate magnetic pieces of scrap material of a first group from magnetic pieces of scrap material of a second group.

In a first case the scrap material originated from so-called end-of-life vehicles. In this case the first group of material exhibited a bulk density of 0.66 ton/cubic meter, and the second group of material exhibited a bulk density of 1.29 ton/cubic meter.

In a second case the scrap material was waste from electrical and electronic equipment. Then the first group of material exhibited a bulk density of 0.73 ton/cubic meter, and the 2nd group of material exhibited a bulk density of 0.93 ton/cubic meter.

It is expressly noted that the above-given description and example merely serves to elucidate the features of the claims without intend to limit the scope of said claims to only the offered example. The scope of protection that merits the invention is entirely and exclusively determined by the wording of said claims without intend to disclaim any feature that might be qualified as equivalent, to any of the features disclosed. Also variations to the offered example are without restriction possible without departing from the scope of the invention as defined by the appended claims.

CLAIMS

1. Use of an apparatus having a separating zone (7) for separating magnetic pieces of scrap-material of a first group (10) from magnetic pieces of scrap-material of a second group (11), which apparatus further comprises a conveyor (2) for transporting a mixture of said pieces of scrap-material (10, 11) from the first group and from the second group to the separating zone (7), at which separating zone (7) the mixture of pieces of scrap material (10, 11) is subjected to a magnetic field and wherein at the separation zone (7) the conveyor (2) is supported by a drum (3) around which the conveyor (2) passes at a pre-defined speed so as to impart on the mixture of magnetic pieces of scrap-material (10, 11) a pre-defined horizontal velocity at which said pieces (10, 11) are released from the conveyor (2) at said separating zone (7) so as to subject the pieces of scrap-material (10, 11) to forces induced by the magnetic field and to gravitational forces, **characterized** in that the first group of material (10) concerns ferrous scrap with a bulk-density of less than 900 kg/m^3 and the second group of material (11) concerns ferrous scrap with a bulk-density of more than 900 kg/m^3 .

2. Use of an apparatus having a separating zone (7) for separating magnetic pieces of scrap-material of a first group (10) from magnetic pieces of scrap-material of a second group (11) according to claim 1, **characterized** in that the forces induced by the magnetic field on the magnetic pieces of scrap-material (10, 11) in the separation zone (7) are constantly and without alternating component attracting said magnetic pieces of scrap-material (10, 11) towards the drum (3).

3. Use according to claim 1 or 2, **characterized** in that the magnetic field has magnetic field lines (13) in the separation zone (7) that are unidirectional.

4. Use according to any one of claims 1-3, **characterized** in that the magnetic field has magnetic field lines (13) that collectively span the entire separation zone (7) and wherein the magnetic field lines (13) share a departure area (12') and arrival area (12'') respectively on the drum (3), which departure area (12') and arrival area (12'') are on distinct halves (3', 3'') of said drum (3).

5. Use according to any one of claims 1-4, **characterized** in that the magnetic field is induced by a single magnet (12)

placed in the drum (3).

6. Use according to any one of claims 1-5, **characterized** in that the magnetic field is induced by a single dipole magnet (12) having a plane (14) separating a north-pole (N) from a south-pole (S) of said magnet (12) that is at a 45°-angle with respect to the horizon.

7. Use according to any one of claims 1-6, **characterized** in that the conveyor (2) moves at a pre-defined speed of at least 2,5 m/s, and preferably at least 3 m/s.

8. Use according to any one of claims 1-7, **characterized** in that the magnetic field has a strength selected in dependence of the conveyor speed, preferably approximately 0,15 Tesla at a belt speed of 3-3,5 m/s.

9. Use according to any one of claims 1-8, characterized in that the scrap material is selected from the group comprising end-of-life vehicles, and waste from electrical and electronic equipment.

10. A method of making steel in an electrical melting furnace, comprising the step of introducing scrap-material into the furnace, which scrap-material is obtained by using the apparatus in accordance with any one of claims 1-9, **characterized** in that the scrap-material is introduced into the furnace in sets of layers whereby for every set of two layers a first layer concerns ferrous scrap of a first group of material with a bulk-density of less than 900 kg/m³, and a second layer which is placed on top of the first layer and concerns ferrous scrap of a second group of material with a bulk-density of more than 900 kg/m³.

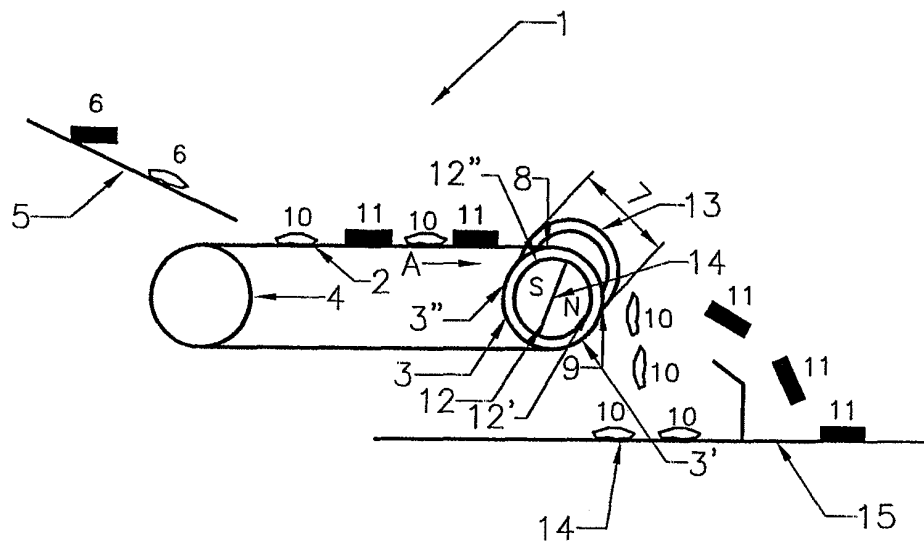

Fig. 1

INTERNATIONAL SEARCH REPORT

International application No
PCT/NL2010/050184

A. CLASSIFICATION OF SUBJECT MATTER INV. B03C1/22		
According to International Patent Classification (IPC) or to both national classification and IPC		
B. FIELDS SEARCHED		
Minimum documentation searched (classification system followed by classification symbols) B03C		
Documentation searched other than minimum documentation to the extent that such documents are included in the fields searched		
Electronic data base consulted during the international search (name of data base and, where practical, search terms used) EPO-Internal		
C. DOCUMENTS CONSIDERED TO BE RELEVANT		
Category*	Citation of document, with indication, where appropriate, of the relevant passages	Relevant to claim No.
Y	EP 1 878 505 A (UNIV DELFT TECH [NL]; RECYCLING AVENUE [NL]) 16 January 2008 (2008-01-16) the whole document -----	1-9
Y	WO 03/053588 A (RAMPAGE VENTURES INC [KY]; MILES DAVID ROGER [CA]) 3 July 2003 (2003-07-03) figure 3 -----	1-9
Y	DE 10 51 752 B (GERD RAYHRER DR ING) 5 March 1959 (1959-03-05) figures 1,2 -----	1
Y	US 3 057 477 A (MAXIMILIANO RAPPAPORT) 9 October 1962 (1962-10-09) figure 3 -----	1
----- -/--		
<input checked="" type="checkbox"/> Further documents are listed in the continuation of Box C.		<input checked="" type="checkbox"/> See patent family annex.
* Special categories of cited documents :		
"A" document defining the general state of the art which is not considered to be of particular relevance	"T" later document published after the international filing date or priority date and not in conflict with the application but cited to understand the principle or theory underlying the invention	
"E" earlier document but published on or after the international filing date	"X" document of particular relevance; the claimed invention cannot be considered novel or cannot be considered to involve an inventive step when the document is taken alone	
"L" document which may throw doubts on priority claim(s) or which is cited to establish the publication date of another citation or other special reason (as specified)	"Y" document of particular relevance; the claimed invention cannot be considered to involve an inventive step when the document is combined with one or more other such documents, such combination being obvious to a person skilled in the art.	
"O" document referring to an oral disclosure, use, exhibition or other means	"&" document member of the same patent family	
"P" document published prior to the international filing date but later than the priority date claimed		
Date of the actual completion of the international search <h3 style="text-align: center;">3 June 2010</h3>	Date of mailing of the international search report <h3 style="text-align: center;">11/08/2010</h3>	
Name and mailing address of the ISA/ European Patent Office, P.B. 5818 Patentlaan 2 NL - 2280 HV Rijswijk Tel. (+31-70) 340-2040. Fax: (+31-70) 340-3016	Authorized officer <h2 style="text-align: center;">Demol, Stefan</h2>	

INTERNATIONAL SEARCH REPORT

International application No

PCT/NL2010/050184

C(Continuation). DOCUMENTS CONSIDERED TO BE RELEVANT		
Category*	Citation of document, with indication, where appropriate, of the relevant passages	Relevant to claim No.
Y	US 2 690 263 A (EDWARD BOX WILLIAM ET AL) 28 September 1954 (1954-09-28) figure 1 -----	1
Y	GB 679 277 A (ELECTROMAGNETS LTD; WILLIAM EDWARD BOX; JOHN THOMAS CLARIDGE; ARTHUR G) 17 September 1952 (1952-09-17) figure 1 -----	1
Y	GB 1 602 279 A (BRITISH STEEL CORP) 11 November 1981 (1981-11-11) figure 1 -----	1
Y	DE 10 2005 032661 A1 (SCHOTT AG [DE]) 20 April 2006 (2006-04-20) figure 1 -----	1
A	EP 0 455 948 A (LINDEMANN MASCHFAB GMBH [DE]) 13 November 1991 (1991-11-13) abstract -----	1-9
Y	US 4 069 145 A (SOMMER JR EDWARD J ET AL) 17 January 1978 (1978-01-17) line 33 - column 10, line 37; figures 2-4 -----	1-9
Y	US 6 568 612 B1 (AOKI TOSHIYUKI [JP] ET AL) 27 May 2003 (2003-05-27) line 52 - column 7, line 64 -----	1-9
Y	US 4 743 364 A (KYRAZIS DEMOS T [US]) 10 May 1988 (1988-05-10) line 25 - column 8, line 52 -----	1-9
Y	US 4 083 774 A (HUNTER JACK A) 11 April 1978 (1978-04-11) line 7 - column 4, line 17 -----	1-9

INTERNATIONAL SEARCH REPORT

International application No.
PCT/NL2010/050184

Box No. II Observations where certain claims were found unsearchable (Continuation of item 2 of first sheet)

This international search report has not been established in respect of certain claims under Article 17(2)(a) for the following reasons:

1. Claims Nos.:
because they relate to subject matter not required to be searched by this Authority, namely:

2. Claims Nos.:
because they relate to parts of the international application that do not comply with the prescribed requirements to such an extent that no meaningful international search can be carried out, specifically:

3. Claims Nos.:
because they are dependent claims and are not drafted in accordance with the second and third sentences of Rule 6.4(a).

Box No. III Observations where unity of invention is lacking (Continuation of item 3 of first sheet)

This International Searching Authority found multiple inventions in this international application, as follows:

see additional sheet

1. As all required additional search fees were timely paid by the applicant, this international search report covers all searchable claims.

2. As all searchable claims could be searched without effort justifying an additional fees, this Authority did not invite payment of additional fees.

3. As only some of the required additional search fees were timely paid by the applicant, this international search report covers only those claims for which fees were paid, specifically claims Nos.:

4. No required additional search fees were timely paid by the applicant. Consequently, this international search report is restricted to the invention first mentioned in the claims; it is covered by claims Nos.:

1-9

Remark on Protest

- The additional search fees were accompanied by the applicant's protest and, where applicable, the payment of a protest fee.
- The additional search fees were accompanied by the applicant's protest but the applicable protest fee was not paid within the time limit specified in the invitation.
- No protest accompanied the payment of additional search fees.

FURTHER INFORMATION CONTINUED FROM PCT/ISA/ 210

This International Searching Authority found multiple (groups of) inventions in this international application, as follows:

1. claims: 1-9

Method for magnetic separation

2. claim: 10

Method for producing steel

INTERNATIONAL SEARCH REPORT

Information on patent family members

International application No

PCT/NL2010/050184

Patent document cited in search report		Publication date	Patent family member(s)	Publication date
EP 1878505	A	16-01-2008	AT 471213 T EP 2206558 A1	15-07-2010 14-07-2010
WO 03053588	A	03-07-2003	NONE	
DE 1051752	B	05-03-1959	NONE	
US 3057477	A	09-10-1962	DE 1147349 B FR 1225338 A	30-06-1960
US 2690263	A	28-09-1954	NONE	
GB 679277	A	17-09-1952	BE 498974 A CH 290183 A DE 854481 C FR 1028108 A	30-04-1953 04-11-1952 19-05-1953
GB 1602279	A	11-11-1981	NONE	
DE 102005032661	A1	20-04-2006	NONE	
EP 0455948	A	13-11-1991	DE 4014969 A1	14-11-1991
US 4069145	A	17-01-1978	NONE	
US 6568612	B1	27-05-2003	DE 10031260 A1 JP 3418787 B2 JP 2001009435 A KR 20010039695 A TW 479007 B	11-01-2001 23-06-2003 16-01-2001 15-05-2001 11-03-2002
US 4743364	A	10-05-1988	NONE	
US 4083774	A	11-04-1978	NONE	