



# Re[Mod]

reuse plastic & robotic modification

**Re[Mod]**

*reuse plastic & robotic modification*

**Master thesis****Ginevra Nazzarri**

*no. 4744756*

30th August 2019

**Mentors**

**Dr.ir. H.H. Bier** | AE+T | Robotic Building

**Dr.ir. F.A. Veer** | AE+T | Structural Design & Mechanics

**Ir. Sina Mostafavi** | AE+T | Robotic Building

**Delegate Board of Examiners**

**Dr. R.J. Kleinhans** | Urbanism | Urban studies



*Delft University of Technology  
Faculty of Architecture and the Built Environment  
Master Track Building Technology*

## Abstract

It is known that the global impact of solid waste is becoming more worrying day by day; however, the application of reused materials in the built environment is not yet fully embraced. In particular, plastic composites are now fundamental for the global world economy but the organization of their end life needs to be improved.

Therefore, the research investigates the possibility of reusing plastic in the built environment through means of robotic fabrication and computational design. Thus exploring different design possibilities based on reclaimed plastic objects, testing their structural stability and robotically modifying them. In order to create a design system for a pavilion made of reclaimed materials, based on a computational workflow.

Throughout the course of the research project, physical testing and software simulations have been performed to assess the properties of the robotically fabricated geometry, in order to retrieve design guidelines. Moreover, a digital workflow was developed including performance-driven design, performance evaluation and geometry generation for robotic fabrication.

To conclude, the study emphasized how rather than employing new resources in the fabrication of a pavilion structure, it is possible to promote the use of reclaimed material using digital techniques and reversing the design process. Instead of designing a shape and consequently choosing a material, the design will start from the choice of a reclaimed material and the analysis of its potential, in order to originate a structure according to it. Besides the research project aims to facilitate the process through the creation of a computational workflow that can be applied to multiple reclaimed objects and shapes.

**Keywords:**

Robotic fabrication - Reuse - Plastic - Pavilion - Computational design - Waste control



# INDEX

<b>1.0</b>	<b>Background</b>		<b>3</b>
		1.1 Context	3
		1.2 Design-to-Robotic-Production	4
<b>2.0</b>	<b>Problem statement</b>		<b>6</b>
		2.1 Main problem	6
<b>3.0</b>	<b>Objective</b>		<b>7</b>
		3.1 General objective	7
		3.2 Final Product	7
		3.3 Boundary conditions	8
<b>4.0</b>	<b>Research questions</b>		<b>9</b>
		4.1 Main	9
		4.2 Sub	9
<b>5.0</b>	<b>Approach and Methodology</b>		<b>10</b>
		5.1 Case studies	10
		5.2 Research design	17
		5.3 Computational system	34
		5.4 Structural analysis	42
		5.5 D2RP	45
		5.6 3D scanning	63
		5.7 Robotic assembly automation	68
		5.8 Final design	71
		5.9 Digital work-flow	88
<b>6.0</b>	<b>Planning and Organization</b>		<b>91</b>
<b>7.0</b>	<b>Relevance</b>		<b>93</b>
		7.1 Societal Relevance	93
		7.2 Scientific Relevance	93
<b>8.0</b>	<b>References</b>		<b>95</b>
<b>9.0</b>	<b>Reflection</b>		<b>96</b>
		9.1 Graduation Topic	96
		9.2 Graduation Process	97
		9.3 Societal Impact	98
<b>10.0</b>	<b>Conclusion</b>		<b>99</b>
		10.1 Main Research questions	99
		10.2 Sub Research questions	100
<b>11.0</b>	<b>Appendix</b>		<b>103</b>

# 1.0 BACKGROUND

## 1.1 Context

In the last few years, world cities have been generating about 1.3 billion tonnes of solid waste per year; and this volume is expected to increase to 2.2 billion tonnes by 2025 (Bhada-Tata et al., 2012).

The global impact of solid waste is becoming more worrying day-by-day, uncollected solid waste could encourage flooding, impact public health and air pollution; In fact, solid waste is an important source of supply of methane, a greenhouse gas that has a great impact on global warming. The waste management industry, to deal with the problem, follows a generally acceptable hierarchy that is meant to take into account financial, social, and environmental issues (Figure 1.1).

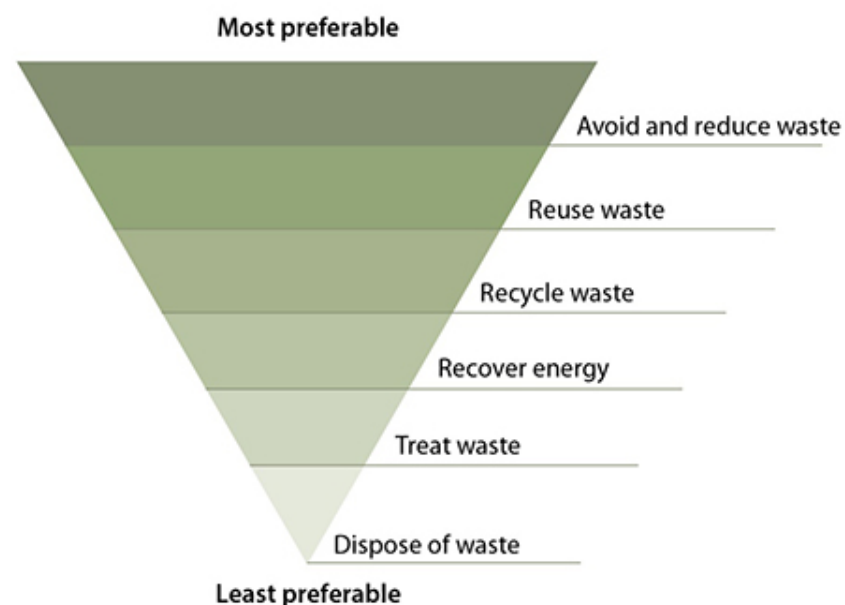

Figure 1.1: Waste hierarchy (Waste Avoidance and Resource Recovery Act, 2001)

However, even if reusing and recycling are increasingly encouraged and regulated by national and local governments, they often result more costly than landfill disposals. In particular recycling can be considered as a good option if the environmental impact and the energy used to collect, sort, and recycle a material are less than the environmental impact and energy required to provide equivalent virgin material, plus the resources needed to dispose of the used material safely (Lave, L. B., et al. 1999). Therefore, considering also the often inefficiency of the recycling systems, reusing seems a better option.

In this context of changing climate, accelerated waste generation and large reduction of the resources, the building industry can play an important role in the system.

Indeed, the designer together with the constructor should consider since the design stage to think differently, in a more sustainable way, using in their project reclaimed or recycled materials or components, with the aim of reducing the amount of waste destined to the landfill and at the same time changing the way the building industry works.

Actually, in recent years there have been some signs of progress regarding the incorporation of recycled or reclaimed materials in the building industry. A successful case, for example, is the New Horizon together with the Urban Mining Collective, in the Netherlands, who recover useable components and raw materials from buildings demolition. In particular, Michel Baars, CEO New Horizon, affirms: *“Circular solutions demand creativity, other perspectives, and forms of application, experimentation and tried and tested methods. We want people to fall in love with a circular economy and design is essential for this. Because circular ideas offer so many opportunities but have not completely taken hold...”*

Furthermore, it is important to mention the problem of plastic composites that because of their many and different applications are now fundamental for the global world economy. While they also represent one of the biggest environmental issues nowadays.

Actually, plastics production has increased twentyfold since 1964, reaching 311 million tonnes in 2014 (Ellen MacArthur Foundation, 2017). Moreover, despite the economic crisis, the world plastics request is continuously increasing and it is expected to almost quadruple by 2050. Therefore with the increase of the plastic production, the plastic share of the global oil consumption and the plastic waste will increase as well, so much that in a business-as-usual scenario, the ocean is expected to contain by 2050, more plastics than fish (by weight).

Currently, the research about the plastic problem is on two levels, firstly the gradual replacement of oil into the manufacture of plastic materials by renewable bio-sourced materials. Secondly the organization of the end life of these plastics through recycling or reusing the products.

However recycling is not always the best option, in fact, soiled plastics and multi-layered plastic products, as an example, are often not suitable or difficult and expensive to be recycled. Therefore, these characteristics make them particularly suitable to be reused.

In this context of not recyclable plastic products, the built environment, while on one side is making a great effort trying to integrate the recycled plastic product into the construction market. On the other side is less progressive regarding the application of reused plastic product in the design; even though plastics is a suitable construction material for any application because it is lightweight and durable. Therefore, would be relevant to consider the appliance of not recyclable plastic components, as a means of construction.

## 1.2 Design-to-Robotic-Production

### Goals of Industry 4.0

It is commonly defined as Industry the part of the economy that produces objects through highly mechanized and automatized systems. Ever since the beginning of industrialization, technological leaps have led to paradigm shifts, which today are ex-post named “industrial revolutions” (Lasi H., 2014). In particular, the first Industrial revolution was related to the mechanization field, while the second regarded the intensive use of electrical energy and the third concerned mainly the widespread of digitalization. Presently, we are in the middle of the fourth technological advancement with the rise of a new digital industrial technology called Industry 4.0.

The basis of this advancement lies in the growth of digitalization within the factories, together with the introduction of new future-oriented technologies in the field of “smart” objects, that regards modern machines and products.

Therefore, this transformation refers to modular and efficient manufacturing systems that will enable us to make processes faster, more flexible and at the same time more cost effective.

The aim of this new industrial revolution is to transform the production flow, from isolated to fully automated and integrated, increasing its efficiency and changing as well the relationship between human and machine.

Robots in this framework play a major role, in fact, even if they are already widely used in the manufactory industry; they are evolving, becoming more autonomous and responsive, and their price is expected to decrease as well.

For instance, Kuka, a European supplier of intelligent automation solutions, developed and placed on the market autonomous robots that are able to work with each other and collaborate with humans.

Likewise, another European supplier for digitally connected and enabled industrial equipment and systems had developed a two-armed robot that has the specific function of assembling products together with humans in a safe environment.

### **Advantages of Design to Robotic Production**

From what mentioned previously, is clear that the question for the future is not anymore if robotic systems will be incorporated into building processes and physically built environment; but how is this going to happen (Bier, 2013).

In this scheme, it is important to understand that some tasks are better accomplished by humans, while others by machines; accordingly, it is crucial to develop future interaction scenarios between the two.

The aim is to involve the robot for tasks that require precision, mass production, and heavy work, while still relying on humans regarding artistry and arrangements.

One of the most promising areas of the building construction for the employment of robot automation is considered prefabrication because some of its processes resemble the ones applied in industrial application (Vähä et al. 2013). However, there are many points to be considered that make the introduction of robots in building construction, quite demanding. Some points worthy to be mentioned, as the higher necessity in building construction for flexibility and adaptability compared to conventional industrial robot applications, the often inaccuracy of the design or the diversity of the building processes that are dissimilar for every building.

Therefore, the most suitable tasks for robots application are still represented by the ones that require a high level of accuracy, speed, constant motion and heavy loads.

# 2.0 PROBLEM STATEMENT

## 2.1 Main problem

*How can computational design and robotic production help to reuse plastic in architecture?*

As already mentioned in the introduction of the report, plastic waste is a great environmental problem that we have to face nowadays. In fact, it is not always possible to recycle plastic objects and sometimes it does not even seem the best option. Consequently, an enormous amount of plastic ends up in the landfill, polluting land and sea.

For this reason, it is becoming every day more important to apply circular economy principles in the built environment, reusing objects otherwise designated to finish in a landfill. To achieve this goal, great support could be given by employing computational design together with Design-to-Robotic-Production (D2RP) methods in order to create a system that could be applied to many different geometries, allowing a considerable amount of freedom in the design but at the same time avoiding randomness.

In fact, thanks to computational design it is possible to build a system that can be applied to many different shapes, while thanks to D2RP it is not lost the complexity and the high level of freedom in the design, because every component can be custom cut in a precise way.

This collaboration between circular economy principles together with computational design and D2RP will allow the designer to aid to the plastic environmental problem, saving many plastic objects from the landfill and at the same time originating constructions with a unique geometry.



# 3.0 OBJECTIVE

## 3.1 General objective

The general aim of this study is to contribute to the efforts in sustainable design research through the help of computational design, D2RP, and structural design.

In particular providing an alternative option to the traditional techniques applied in the building construction, promoting the practice of reuse in architectural design, delimiting as well the limits of it.

Firstly, the aim of this study is to build a system based on reused plastic components that could be applicable to many typologies of structure and geometry, allowing freedom in the design and encouraging as well geometry complexity, through the study of it in different scales, the material, the component, and the pavilion scale.

The second objective of this research is to find a few components, suitable for the design, from different points of view (strength, complexity, recyclability, shape, geometry...). In order to push forward the current research about reusing, avoiding the repetition of a single component but instead promoting the combination of different ones.

## 3.2 Final product

The final product of the design will be a temporary structure, in particular, a pavilion, for outdoor use during the summer season; could be employed for instance in festivals, events or even on our campus.

The design of the pavilion is highly flexible because it depends first of all on the desired shape, then on the tessellation of the faces of the pavilion, that could include the use of different polygons, such as triangles, quadrilaterals, pentagons and hexagons, and finally on the dimensions of the pavilion.

The different components will be placed within the pavilion scale according to different requirements, as structural ones, regarding the performance of the overall structure, the strength of each component and the optimal geometry. Moreover, the architectural aspects should be considered, in fact, it should be able to provide shade, therefore the transparency ratio and the number of openings should be placed in strategic locations.

Additionally, being a temporary structure, it should be easy to disassemble; therefore, all the connections should be made of solutions like snap fit or nut and bolt. Otherwise, in case the welding connection results more efficient, the size of two components welded together should be still manageable by hand.

To conclude, this typology of structures, based on components that are designated to end in a landfill, could have an interesting application in developing countries, where the construction materials are in short supply.

## 3.3 Boundary conditions

The main restriction for the research is certainly the application of reused components. In fact, the research of possible components, that could be suitable to be used as a construction material, is the starting point of it.

The main requirements that would make a plastic element suitable for the design are the non-recyclability, the difficulty in reusing the objects in daily life, the strength and a wall thickness of at least 1 mm, in order to be able to modify the object with D2RP techniques. However, it is not necessary for the components to be selected, to possess all the requirements at the same time.

The connection between the components is, as expected, another important point to consider in the design, indeed to preserve the coherence of the project is preferable to avoid as much as possible the use of extra material, therefore, as stated above, snap fit and nut and bolt connections are favored.

In these circumstances, it is evaluated that the design outcome of the research should be a pavilion. Actually, is more appropriate to speculate about possible uses for the reused plastic components at a pavilion scale, avoiding the proposal of load bearing structure such as buildings. Most of all because the main material adopted for the research is plastic and even if it is a strong material, it would lead to fire safety issues.

However, even if a pavilion scale and in particular a temporary structure has certainly fewer constraints compared to a building, some requirements are still needed to be considered, such as the demountable feature, and the application of nearly zero extra material.

Moreover in terms of freedom in design, shape, and geometry, using reused components that were not entitled to be construction materials, requires from the architect more flexibility in finding a compromise between the overall design idea and the usage of existing objects.

In fact the overall way of thinking about the design it's changing; While on one hand, in case of a design based on new materials, the design process starts from the macro scale, where the designers identify the function of the structure, the shape and in a second moment selects the material.

On the other hand, for this research, the design process starts from the Meso scale, the component scale, and after studying some objects to understand if it could be feasible to use some of them for construction purposes; it was possible to identify possible uses for a structure based on such components.

# 4.0 RESEARCH QUESTIONS

## 4.1 Main research question

The study considers the hypothesis that plastic objects that are designated to end up in a landfill, could still have the potentiality to be reused, and some of them even be applied as construction material. Therefore, the introduction of this practice into the built environment would have great effects on the problem of plastic waste and on its share of the global oil consumption. In the context of sustainable design research, the following research question was formulated:

*How can we reuse plastic objects in the building industry in order to contribute reducing the problem of plastic waste and its share of global oil consumption?*

## 4.2 Sub research questions

In the context of supporting a different way of thinking about plastics, according to the fundamentals of the circular economy, the following sub-research questions were defined, in order to establish:

*How can we elongate the life of a plastic product avoiding the use of new materials and applying it to the built environment?*

*How could we use plastic objects in an upcycle scenario?*

The research will be conducted on different scales; hence, it will also be possible to conclude:

*Which requirements do the plastic components need to have to be used for the construction of the pavilion?*

*What strategies can be adapted to connect the plastic components with each other without the use of extra material?*

In the framework of a wide range of opportunities offered by the current technology advancement and the Industry 4.0, the following sub-questions were formulated:

*How can computational design and 3D scanning assist the designer in ideating a construction system based on reused components?*

*How can robotic fabrication aid to the reuse of plastic components?*

*What are the limits in shape and geometry when reusing objects and how can robotic fabrication help us to overcome them?*

# 5.0 APPROACH AND METHODOLOGY

## 5.1 Case studies

### Blobwall

Greg Lynn, in his project called Blobwall, used as a starting point of his design, hollow plastic toys to reinvent hollow plastic rotomolded components. In fact, by means of 3D scanning, the plastic toys are first geometrically defined in 3D and then reproduced to create freestanding walls and enclosures. Each one of the components is custom cut by Computer Numerically Controlled robot arm and is specifically trimmed to a unique shape based on how it intersects with the next one. Indeed the complex interlocking between the components is defined through a 3D model, the intersecting curves are extracted and used to program the CNC robotic arm with a cutting head that custom trims each element.

The wall is therefore assembled and heat welded from individual robotically trimmed hollow components that interlock with exacting precision, eliminating the need for glue.

To conclude, the project of Greg Lynn results particularly interesting for this research because of the system behind its creation and assembly. In fact, using only one component that was meant to be a plastic toy, he was able to create a wall structure that has a similar logic to a traditional brick wall, changing the function of the plastic components from toys to construction materials.



Figure 5.1: Blobwall (Greg Lynn, 2005)



## EcoARK

EcoARK is a massive pavilion built in Taiwan, it is made of 1.5 million recycled plastic bottles. The design is so accurate that the pavilion is able to withstand fires and earthquakes. It is also powered by solar energy and was built to the mantra of "Reduce, Reuse, and Recycle."

The basic component of the design is called "polli-brick", a hollow building block that has a shape similar to the one of a bottle and it is made of more than a million recycled PET bottles. The new building components fit perfectly together and they require only a small amount of silicone sealant. Once assembled are then coated with fire and water resistant film. Moreover, the air inside the plastic components provides insulation against the heat and their transparency allows natural light to come through the building during the day.



Figure 5.2: EcoARK (Far Eastern Group & Arthur Huang, 2010)

## One Bucket at a Time

One Bucket at a Time is a project in Mexico, for an interactive pavilion made of common painter's buckets that are connected together with a system of ropes. The structure works as a malleable surface that the visitor can roll, pull together or up to a point or along a line changing its shape and geometry. It is also interesting to notice that the temporary structure was used by the population to reclaim ownership of their public space.



Figure 5.3: One Bucket at a Time (Factor Eficiencia & 5468796 Architecture, 2017)

## Bonheur Provisoire

The Bonheur Provisoire was a temporary pavilion made in Brussels, in front of the Atomium, for the 50th anniversary of the 1958 Universal World Exhibition.

It was made using around 33 millions plastic beer crates, connected together like Lego, in order to originate domes, columns and arches.

It is noteworthy that the designers affirmed that the construction of a temporary building can only be justified when it doesn't create waste and it follows the principles of reuse and recycling. Moreover, in this case, after the disassembly of the structure, the beer crates will return to their original use.



Figure 5.4: Bonheur Provisoire (SHSH, 2008)

## GiRA

GiRA was a temporary art installation realized for the annual event Oporto (St. John's celebrations). The installation aims to create a new playful space in the city, in fact the structure incorporates a swivel mechanism that once you enter the structure can be activated manually, allowing the installation to rotate.

It is particularly interesting for the aim of the research because of the idea of repurposing an object. Indeed the exterior of the installation is made of hundreds traditional plastic hammers, normally used by childrens to play, that are instead used as "cladding material" to create a curved surface.

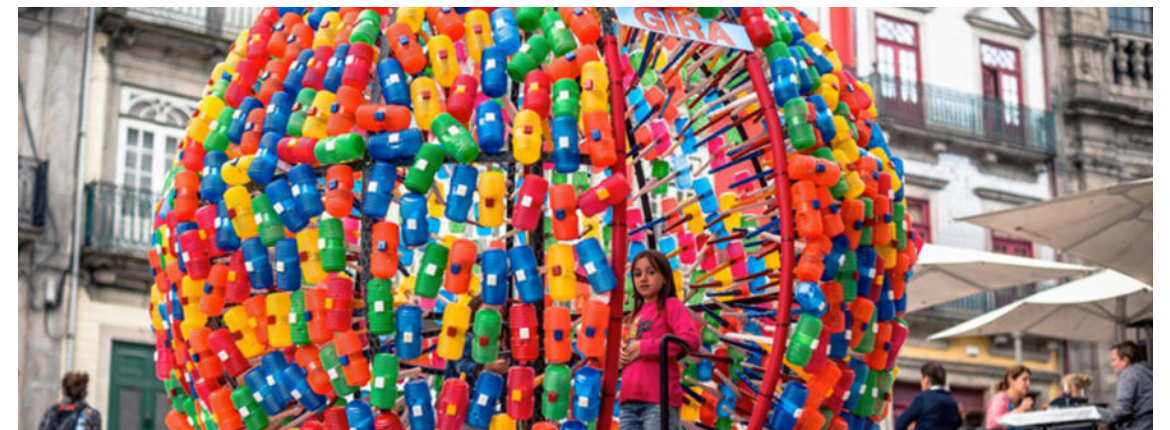

Figure 5.5: GiRA (Miguel Costa & Meireles de Pinho, 2016)



## Tetra brik pavilion

In 2013, in the occasion of the International Recycling Day, it was established the collaboration between the Department of Environment of the Government of Granada and the waste company RESUR. Together, they wanted to explore the recycling and construction possibilities of the standard milk carton. The result was pavilion built of more than 45,000 milk cartons. The used milk cartons were collected in more than 100 schools in the province of Granada. The milk cartons were then connected to each other with clamps and bridles, originating a structure that is 30 meters long, 15 meters wide and 7 meters high.



Figure 5.6: Tetra brik pavilion (DEGG + RESUR, 2013)

## Bima Mircrolibrary

This small local library, situated on a square in the city of Bandung and designed by the local architectural firm SHAU, is made of a steel skeleton with a concrete slab as roof and floor. The use of concrete and steel, both cold materials, in contrast with a perforated façade creates a comfortable indoor climate. The façade is made of ice cream buckets, which were collected from the local community. A part of the buckets has been stripped of the bottom, creating openings for better ventilation.



Figure 5.7: Bima Mircrolibrary (SHAU, 2016)

## Skyscraper, the Bruges whale

This sculptural whale is made of waste that has been collected from the Pacific Ocean. In total, StudioKCA, a Brooklyn-based design agency, collected 5,000 pounds of waste to compile the sculpture by color.

Skyscraper, the Bruges Whale, name of the sculpture, refers to the 150,000,000 tons of plastic waste floating in the ocean. In fact, the studio is trying to create people awareness regarding the problem of plastic pollution, emphasizing its effect on the ocean. This project was made for the Bruges Triennale 2018 that had as a theme "liquid city".s case, after the disassembly of the structure, the beer crates will return to their original use.



Figure 5.8: Skyscraper, the Bruges whale (StudioKCA, 2018)

## Gallery of furniture

A young and talented architectural firm from Brno, caled Chybik + Kristof, is responsible for the transformation of an old garage into a showroom for office, school and metal furnitures. The office has transformed the facade of the one-storey high garage complex into an innovative, eye-catching building. The new façade, made of 900 black plastic seat and tubes, in addition to having a low budget, has an abstract and graphic quality. Moreover, in 2017, Chybik + Kristof won the Architecture Grandprix 2017 with this project.



Figure 5.9: Gallery of furniture (Chybik + Kristof, 2016)



## Living pavilion

This summer pavilion was placed in the Nolan Park on Governors Island. Living pavilion provides shade and is therefore the ultimate place to relax. It was designed by the duo of Ann Ha and Behrang Behin. The pavilion is made of wooden curved ribs in combination with white plastic milk crates, which were produced by Admar Plastics, company that not only makes crates but also recycles them. There are two types of plants in the crates, the plants below, called Liriope, can grow inside because they survive in the shade; instead, for the crates placed on top, it was used grass. Concluding some crates were left empty to allow the light to go through the pavilion.



Figure 5.10: Living pavilion (Ann Ha and Behrang Behin ,2010)

## Head in the Clouds Pavilion

The pavilion was built by Studio KCA in 2013, in occasion of the event organized by the arts organization Figment on New York's Governors Island. It was made of 53,780 recycled bottles which correspond to the number of plastic bottles thrown away in New York City in only one hour. The bottles were collected around the city through different means and then assembled around an aluminium structure, already bended in shape. The exterior of the pavilion, thanks to the natural color of the plastic looks like a cloud, as the name suggests, instead for the interior surface, some bottles were filled with colored water to create a pattern. Moreover the weight of the water made sure that the pavilion didn't need any foundation to be stable.



Figure 5.11: Head in the Clouds Pavilion (StudioKCA, 2013)

## Trussfab

Phd researcher Robert Kovacs at the Hasso Plattner Institute in Potsdam, together with his team from the Human Computer Interaction lab created a Sketchup plugin, which is able to create structural sound structures from the use of recycled plastic bottles, combined with 3D printed nodes. Therefore, the user is able to create a new geometry based on the Trussfab system or to convert an existing geometry into a Trussfab structure, thanks to the structural system integrated in the plugin, which is based on the repetition of the truss structure principles. The plugin will then originate 3D model files of every connection, allowing the user to directly 3D print them, making the structures relatively easy and fast to build. Concluding to use Trussfab the user doesn't need any specialized machinery or engineering knowledge and is able to build large scale structures that are even capable of bear human weight.



Figure 5.12: Trussfab ( Robert Kovacs, 2017)

## Watershed

Rotterdamwatershed is a temporary pavilion created for the World Cities Pop-up Expo in Edinburgh, with the aim of putting emphasis on the innovative strategies applied by the city of Rotterdam in terms of climate adaptation and mitigation.

It is made of 2400 recycled PVC rainwater pipes, where half of the pipes are closed on the outside using plants and the other half is closed on the inside using PVC caps. The latter have some small holes on their surface that allows the water to infiltrate the pavilion when it is raining. The rainwater is then stored in the base of the pavilion that being able to trap the water creates a pond, which is possible to cross thanks to the introduction of stepping-stones.



Figure 5.13: WATERSHED (Doepel Strijkers, 2016)



## 5.2 Research design

### MICRO - Material scale

The word plastic is used indiscriminately to refer to any artificial material, but there are thousands of different plastics.

Chemist and professionals prefer to define it in terms of its chemistry, calling it a polymer. In fact, plastic materials consist of many repeating groups of monomers in long chains and hence are also known as polymers. Its central atom is nearly always carbon, while the hydrogen atoms complete the basic molecular structure. For example, a one-carbon molecule attached to four hydrogen atoms is called "methane," a major part of natural gas that has a great impact on global warming.

The molecule methane looks like this:

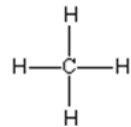

Indeed the components needed to manufacture plastic are extracted from a variety of natural substances such as natural gas, petroleum, coal or other mineral and organic materials.

Plastic can be divided into two major categories:

1. Thermosetting plastics, such as polyurethanes, polyesters and epoxy resins.
2. Thermoplastics, such as polyethylene (PE), polypropylene (PP) and polyvinyl chloride (PVC).

Thermoplastics represents the majority of polymers used today, in terms of recycling they are divided among 7 families. However, even if recycling is often possible, it is not always economical to do so, thus some plastics are recycled more often than others are.



Figure 5.14: Plastic packagings (BBC Analysis Data, 2018)

### MESO - Component scale

The meso scale refers to the component scale and in case of a structure based on the reused object; it is the starting point of the design.

The research of possible components was performed according to some main parameters, such as the non-recyclability, the difficulty in reusing the objects in daily life, the strength and a wall thickness of at least 1 mm, in order to be able to modify the objects with D2RP techniques. Requirements already discussed in the paragraph regarding the Boundary conditions of the design.

Afterward, the research has been carried out from a physical point of view, through the exploration of different locations, however only three of them resulted relevant for the project.

The first location is called **Scrap XL**, a store in Rotterdam that gives to waste material a second chance. It is selling waste material such as plastic, cardboard, fabric, rubber, and others, to give to the people the occasion to build something out of it. Moreover, the shop is particularly interesting for the research because it is possible to find their many pieces of the same component. In fact, the items that are sold at the store, are coming directly from the manufacturing industry, therefore they are still in optimum condition.

The second location is a recycling shop present in different cities in the Netherlands, called **Rataplan**. For the purpose of the research were visited the Rataplan in Delft and the one in Spijkenisse. Despite the bigger amount of objects present in the two stores compared to the quantity available at Scrap XL, the latter appeared more suitable for the research. First because in the Rataplan is mainly possible to find objects that could easily be reused in daily life and second because is usually possible to find only one piece per each item.

The third place is **Buurman**, a shop for reclaimed materials and a wood workshop that is present in Rotterdam and is opening in Utrecht. It was visited the shop in Rotterdam where it was possible to find different kind of reclaimed materials, the majority was actually based on wood but there were also plastic pipes, glass plates and even doors, window frames, etc..

After the research in the stores, some components were selected because suitable and interesting for the design. However, because the research is an ongoing process, the components were not selected all at once but first were selected the pieces for the joint, that is the most complicated part of the design, and in a second moment were selected also the components for the ribbon structure and for the tessellation of it. On this purpose, it is also important to notice that some components considered in a first moment relevant for the design, could possibly be discarded in a second phase of the research project.



## Disposable keg

The first one is a disposable keg, which is used to store and transport beer, wine, cider, and soft drinks and it can be found in different design variations according to the brand. A pressure release tool is used to let out the air from the kegs.



Figure 5.15: disposable keg

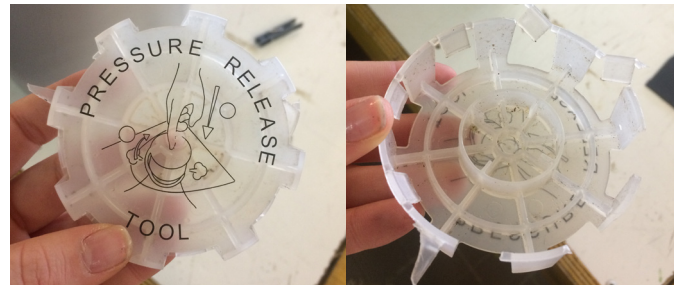

Figures 5.16: pressure release tool (top and bottom)



Figure 5.17: different kegs design variations

It is interesting for the research because the disposable is widely used in Holland so there is a great deal of components available. In fact, it has already been considered to reuse it, and one of the most successful examples, also because easy to realize, is its transformation into a stool. Indeed only connecting a wood piece on top of it, it is possible to easily create a stool, as show in the Figure 5.16 where at the Fenix Food Factory in Rotterdam are already reusing the disposable kegs as a sitting area in front of the counter.



Figure 5.18: Fenix Food Factory - disposable kegs



Figure 5.19: Fenix Food Factory - disposable kegs

## KEYKEG® Technical Specifications



General	10L	20L	30L
Cycle		Single use	
Pre-pressure		2.2 bar (± 0.3 bar) (32 psi)	
Filling		Upside down	
Connection		KeyKeg	
Fill before		< 18 months after production date	

Dimensions/weight	10L	20L	30L
Volume*	10 liters (2.64 gal US)	20 liters (5.28 gal US)	30 liters (7.93 gal US)
Diameter	240 mm (9 1/4")	240 mm (9 1/4")	300 mm (11 3/4")
Height	330 mm (13")	572 mm (22 1/4")	572 mm (22 1/4")
Weight	1.0 kg (2.14 lbs US)	1.2 kg (2.65 lbs US)	1.5 kg (3.31 lbs US)

\*KeyKegs are designed for counter pressure filling. The volume of the filled keg will depend on the pressure used.

Shelf life/Barrier properties	10L	20L	30L
Migration per 6 months at 20°C			
O <sub>2</sub> pick-up	<0.3 mg/L (ppm)	<0.2 mg/L (ppm)	<0.3 mg/L (ppm)
CO <sub>2</sub> loss	<7%	<7%	<5%

Resulting in a shelf life equal or even better than stainless steel kegs

Mechanical properties	10L	20L	30L
Temperature range	0-40 °C / 32-104 °F		
Max. CO <sub>2</sub> level	7.1 g/l / 3.5% vol		
Burst pressure	>12 bar (174 psi)		
Max. working pressure	Depending on dispense coupler (Exceeding activates pressure relief valve)		

© Lightweight Containers, May 2018  
Disclaimer: The information contained herein is offered for use at your own discretion and risk. All statements, technical information and recommendations contained herein are based on tests and data that Lightweight Containers believes to be reliable, but the accuracy or completeness has not been verified and is not guaranteed. No warranty of any kind is made with respect to any of the above representations.

## KEYKEG®

**Materials**  
All food contact materials are approved according to regulations FDA 21 CFR 177.1520, EC 1935/2004, EU 10/2011 and/or further amendments.

Materials	10L	20L	30L
Gripring	Recycled PP		
Outer container	PET		
Closure	PA (Glass fibre reinforced)		
Inner ring	PP / SEBS		
Spout	PE		
Valve	PP / SEBS		
Inner container	PET		
Inner bag	PE/Alu/PA laminate		
Sleeve	PE		
Basecup	Recycled PP		



© Lightweight Containers, May 2018  
Disclaimer: The information contained herein is offered for use at your own discretion and risk. All statements, technical information and recommendations contained herein are based on tests and data that Lightweight Containers believes to be reliable, but the accuracy or completeness has not been verified and is not guaranteed. No warranty of any kind is made with respect to any of the above representations.

Figure 5.20: Disposable kegs KEYKEG - Technical Specifications



## Sandvik coromant drill container

The second component is from Sandvik Coromant, a metalworking industry specialized in manufacturing tools. The component is a hollow and openable plastic object used to transport and store different typologies of drilling heads and it is available in many design variations according to typology and size of the drill (Figure 5.22).



Figures 5.21: Sandvik Coromant drill container

It is entirely made of polyethylene (PE) and at Scrap XL are available many components, mainly in two different variations. They are both made out of two pieces, a body and a lid that is screwed up on it, in one case, the body has a regular cylindrical shape and in the other, it has a more complex shape (Figure 5.23 and Figure 5.24). It was chosen, for the research project, the component with the more intricate shape because it results stronger.



Figures 5.22: Sandvik Coromant - different typologies of drill containers

## Technical Specifications

All the dimensions of the components are estimated with a measuring tape, therefore some degree of uncertainty that may come from a variety of sources should be considered.

### Component 1

#### Bottom

Square Base: length and width of 11.6 cm

Circular base: diameter of 10.7 cm

Height: 18 cm

Thickness of the walls: 0.08 cm

#### Top

Circular Base: diameter of 11.5 cm

Height: 10 cm

Thickness of the walls: 0.08 cm



Figure 5.23: Sandvik Coromant drill container - component 1

### Component 2

#### Bottom

Hexagon base: side lengths of 7 cm

Circular base: diameter of 10.5 cm

Height: 15.5 cm

Thickness of the walls: 0.08 cm

#### Top

Circular base: diameter of 11.3 cm

Height: 17.9 cm

Thickness of the walls: 0.08 cm



Figure 5.24: Sandvik Coromant drill container - component 2

## Sinterama plastic cone

The third one is a plastic cone used by the Italian company Sinterama, which is specialized in the production of coloured polyester threads and yarns, to wrap around it their different yarn.

It is in particular used for their sustainable yarn, called Newlife, which is made out of high performance recycled polyester yarn, made from post-consumption plastic bottles collected.

The different cone components were retrieved at Scrap XL, where they are available in two different heights and eight colour variations.



Figures 5.25: color variation

### Technical Specifications

As already stated above, in this case, as well as the previous one, all the dimensions of the components are estimated with a measuring tape. Therefore, some degree of uncertainty that may come from a variety of sources should be considered.

#### Typology 1

Circular bottom base: diameter of 7.3cm  
Circular top base: diameter of 4.4 cm  
Height: 23 cm  
Thickness of the walls: 0.1 cm

#### Typology 2

Circular bottom base: diameter of 7.3 cm  
Circular top base: diameter of 4 cm  
Height: 26 cm  
Thickness of the walls: 0.1 cm



Figures 5.26: typology 1 and 2 of the cones



Figure 5.27: cone component

## Kima disposable laboratory ware

The fourth component is from the Italian industry Kima, which is specialized in the production of disposable laboratory ware.

It is a polyethylene (PE) container bottle shaped use to collect sample of liquid, which is why it is graduated. It is also equipped with two screw caps and one handle.

It was also retrieved at Scrap XL, where many more of the same component were available. Moreover, because of its mediums size dimensions and its volumetric regular shape; it is particularly suitable for the research.



Figures 5.28: Kima disposable laboratory ware

### Technical Specifications

As already stated previously, all the dimensions of the components are estimated with a measuring tape. Therefore, some degree of uncertainty that may come from a variety of sources should be considered.

Circular bottom base: diameter of 13 cm  
Screw cap A: diameter of 8 cm  
Screw cap B: diameter of 3 cm  
Height: 28 cm  
Thickness of the walls: 0.1 cm



Figure 5.29: Kima disposable laboratory ware



Figure 5.30: Kima disposable laboratory ware



## Structural Tests - 18.12.2018

The three typologies of selected plastic components were then tested at the laboratory of the faculty of Mechanical, Maritime, and Materials Engineering (3ME) of the TU Delft, led by Dr. ir. F.A. Veer.

The tested specimens were laid in between two steel plates and subjected to the compression test. The test bench was a Zwick z10 with constant downward displacement, which was used to measure the force required for the deflection; the results were then transferred to an Excel environment. The results obtained from the compressive testing are saved in an excel file that plots the necessary force to reach a particular level of deflection. The "useful range" in which we can determine the compressive stress of our plastic components is then determined.

This is needed because once the components are compressed too much, their surface area increases resulting in a new equilibrium in which the allowable compressive strength becomes higher again, leading to inaccurate results. If such components were used in a structure, the structure would have already deformed excessively and collapsed before reaching the compressive limits. To conclude the compressive stress is considered within the first "peak" of the F/d diagram, as such a peak is indicative that boundary conditions have changed (such as a cracked plastic component).

### Results

The test performed in the laboratory were eight, where the specimens selected were eight as well but from three different typologies. In fact were tested the plastic components showed above in the meso scale; in particular, firstly two different kegs, then three drill containers and to conclude three cones of different colors.

The tested kegs showed a peak between 250 kg and 300 kg without deformations, then the kegs are deforming while releasing the gas. As expected, after the deformations the kegs start to fold on themselves, therefore the compressive strength becomes higher again because of the increased surface area.



Figure 5.31: disposable keg I test 1



Figure 5.32: disposable keg I test 2

The drill container is first tested alone, showing a peak close to 80 kg. The test highlighted that the base is the weaker part of the element; in fact, because there is a single layer, it starts to buckle out instead the central part results stronger because it is made of two layers.



Figure 5.33: drill container I test 3

The fourth test was then performed with two drill containers stacked on top of each other. This resulted in a complicated buckling test, most of all because the components are not connected but it was performed to analyze how the components interact together. The peak was close to 75 kg and it was visible from the side, that with the increase of the load, the bottom component started to shift backward.



Figure 5.34: stacked drill containers I test 4

Afterward, the bottom component, retrieved from the previous test, was examined again, because even if the components are the same, they always behave slightly different on the buckling test.

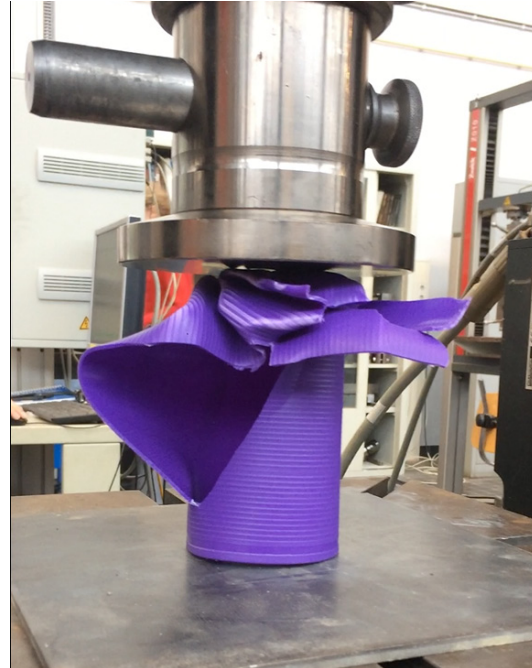

Figure 5.35: violet cone I test 6

To conclude the cones objects were tested in three different colors, respectively violet, grey and green. The first tested cone, the violet one, showed interesting forces, with a peak around 300 kg but the plastic results brittle, in fact, it cracked. However, even when the crack is wide open, the cone still holds almost 300 kg. Subsequently, the green cone was tested, showing a behavior similar to the violet one, with a peak around 250 kg, when it starts to crack.



Figure 5.36: green cone I test 7

To conclude, the grey cone was tested, showing an example of perfect buckling. Indeed, how it is possible to notice also from the graph trend, the object results -more ductile than the precedent one, folding in itself and showing a peak around 450 kg. It is clear from the test that even two plastic components that look the same but present only a small difference (in color), can have completely different behavior.

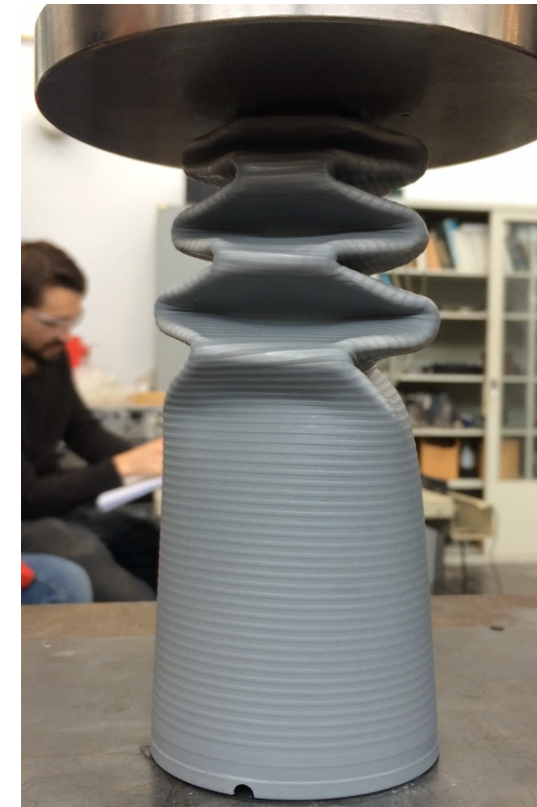

Figure 5.37: gray cone I test 8

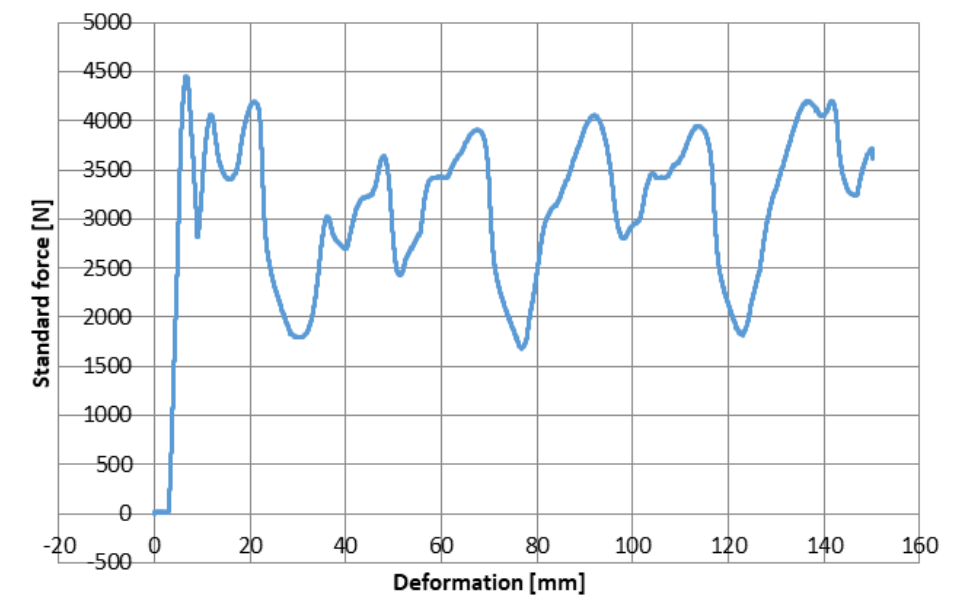

Figure 5.38: graph Force [N] / Deformation [mm] gray cone I test 7



## Selected components

The selection of the components was based on the analysis of their different shapes, to understand which one could fulfil the requirements for the different elements of the structure: joints, ribbon structure and panelization.

### Joint

The design of the joints started from the idea of taking advantage of the flat base of the **Sandvik coromant drill container** to create junction elements. In fact, the above-mentioned object was selected because of the quadrilateral shape of its base, which makes it particularly suitable for the repetition and connection of the same element around a single vertex to create a junction. Moreover, from a structural point of view, during the tests the component showed an acceptable strength, mostly because of the intricate shape of its central part, which consists of two layers, compared to the bottom part, which consists in only one layer. Additionally the drill container was selected as first component for the research because it was the only one that could change size; indeed consisting of two parts, the top part of the components can make the component longer or shorter, according to how much the lid is screwed on top of the bottom part. Therefore, the length of the component can vary from a basic length of 20 cm to 25cm. To conclude the openable feature of the component makes it easier to use when dealing with mechanical connections, because it is possible to reach the connection element also from the inside.

In a second moment, to improve the functionality of the joint, together with the design of the overall structure, it was decided to introduce another component in the construction of the joint. The component will be used to connect the plastic foil, used in the tessellation, to the structure of the pavilion. The selected component is the **Kima disposable laboratory ware**, which was selected, first of all because of the compatible size compared to the drill container component already used in the joint; Second because thanks to its length and its regular cylindrical-faceted shape could act as a central core in the joint, to which all the other components are connected. Thus, the Sandvik coromant components will be placed parallel to the ribbon structure, while the Kima component will be placed perpendicular to it. Furthermore, also this component like the other ones used in the joint, is openable; in fact it is equipped with two screw caps, of which one is large enough to access the inside surface of the component.

### Panelization

Regarding the membrane used to cover the facets of the pavilion, different typologies of reused fabrics were selected and examined. In fact, considering the complexity of the orientation of the faces, it was necessary to adopt a fabric that is stiff in both directions. Between the below shown materials, the most suitable and interesting from an architectural point of view resulted the fabric used as truck protection, which is a heavy fabric and the **semi-open membrane**, used as outdoor sign.



However, it was also observed that is unlikely that the junction between the fabrics of different faces would be watertight. Therefore, a lighter fabric, that would add less weight on the structure, creating ornate shadows and allowing the light to partially go through the pavilion, was selected. The selected fabric (Figure 5.39) is semi-open but still stiff and water repellent because it was used as an outdoor sign for a fashion stock. In fact, it has a geometrical pattern and some writings on it. The measure of the membrane are equal to 330x173 cm.

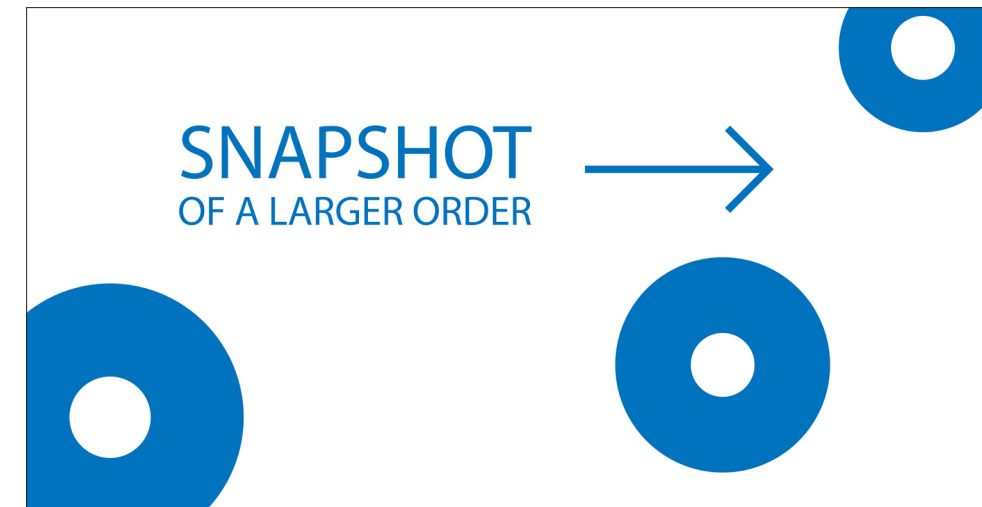

Figure 5.39: semi open membrane

### Ribbon structure

For the ribbon structure, it was necessary to find a component that was long enough to cover the all length of the ribs. In fact, the option of dividing the ribs of the structure in two parts would lead to a solution where the maximum bending moment of the all rib would overlap with the connection between the two elements. Furthermore, considering of splitting the rib in even more than two parts would lead to an even higher loss of strength and stability for the overall structure. Therefore, for the ribbon structure, it was decided to use **PVC pipes for water supply**, that would fulfil the requirements of being long enough to cover the all length of the rib and it is not difficult to retrieve already used ones still in good conditions.

Another considered option was to use empty toner bottles; however, they are only available in a maximum length of 1m so it would be an additional design limitation.



Figure 5.40: PVC pipes for water supply

## MACRO - Building scale

### Conceptual Design

The macro scale is the largest scale of the design and it refers to the geometrical organization of the components within the pavilion structure.

The design idea started from the analysis of the potentials of the components, to create a system and avoid randomness in the design. In particular, the concept is to take advantage of the flat base of the drill container object to create junction elements out of patterns of triangles, quadrilateral, pentagons, and hexagons to create stable structures; as it was already done by Buckminster Fuller in the '90s with the geodesic dome. In fact, a geodesic dome is a structure based on a geodesic polyhedron that is a geometry made of the repetition of triangles.

Therefore, the design was firstly studied in plan, through the positioning of the nail container object around some polygons shapes. Specifically, the system is based on the division of a random circle in different parts, where the center of the circle will be the center of the junction. For example, if the circle is divided into three parts, it means that three components will be used for the joint and in this case, they will form a triangle in the center of the circle.

In the same way, if the circle is divided into four parts, four components are needed for the joint and together they will form a quadrilateral in the center of the circle. Likewise, applying the same system, if the circle is divided into five parts, the components will form a pentagon and if is divided into six parts, they will form a hexagon.

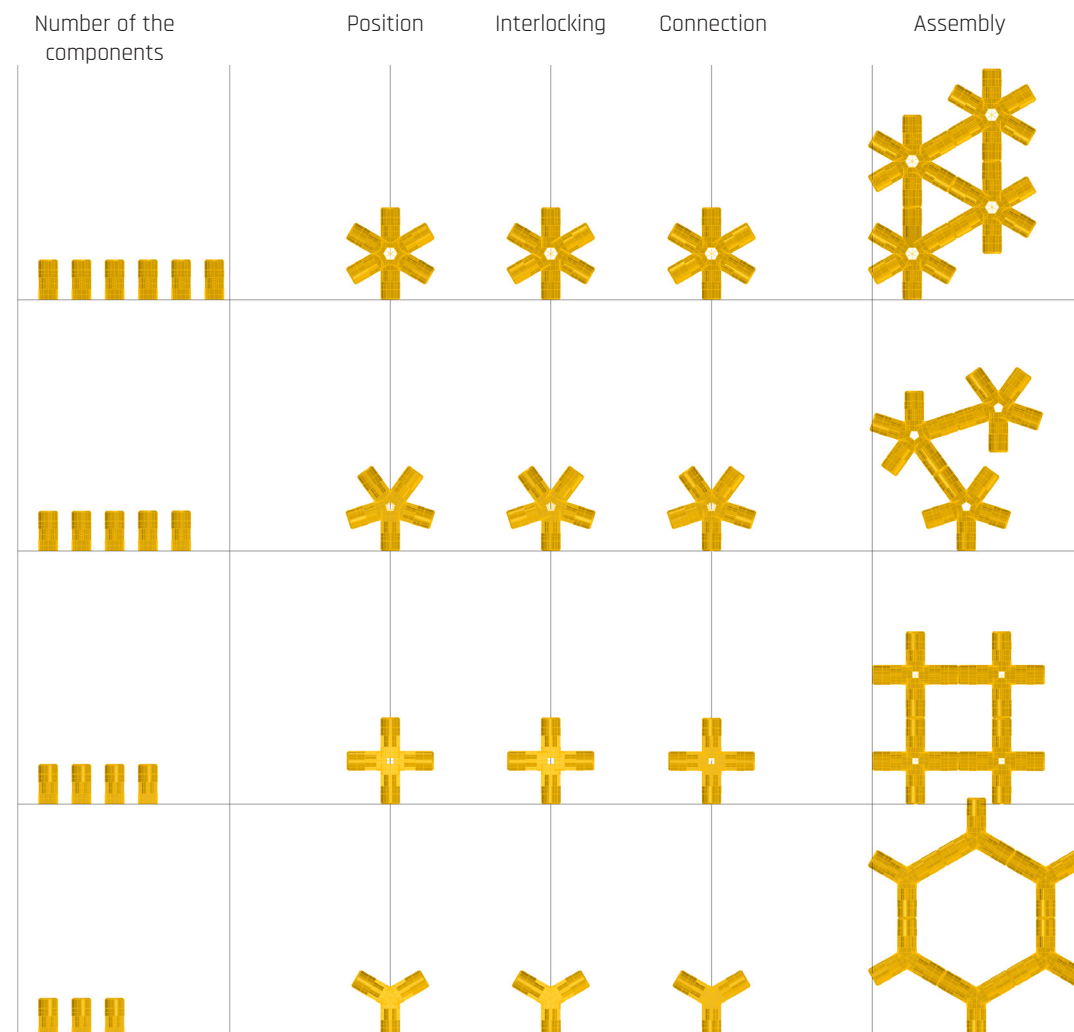

Figure 5.41: study of the design in plan

Moreover, it was studied in plan a method to connect the components together, cutting on one side the part where they overlap and leaving it on the other side, in a way to create a system based on interlocking components that could be bolted together, as is shown in Figure 5.24 for a junction made of six components.

Therefore, the junctions were repeated and assembled together vertex-to-vertex, originating as well different polygons shape, such as a hexagon for the connection based on three components, a quadrilateral for the connection based on four components or a triangle, for the connection based on six components (as is shown in Figure 5.42). While it was also discovered that the Pentagon could not be tessellated in plan (Figure 5.47) because in order for a regular polygon to tessellate vertex-to-vertex, the interior angle of the polygon must divide 360 degrees evenly.

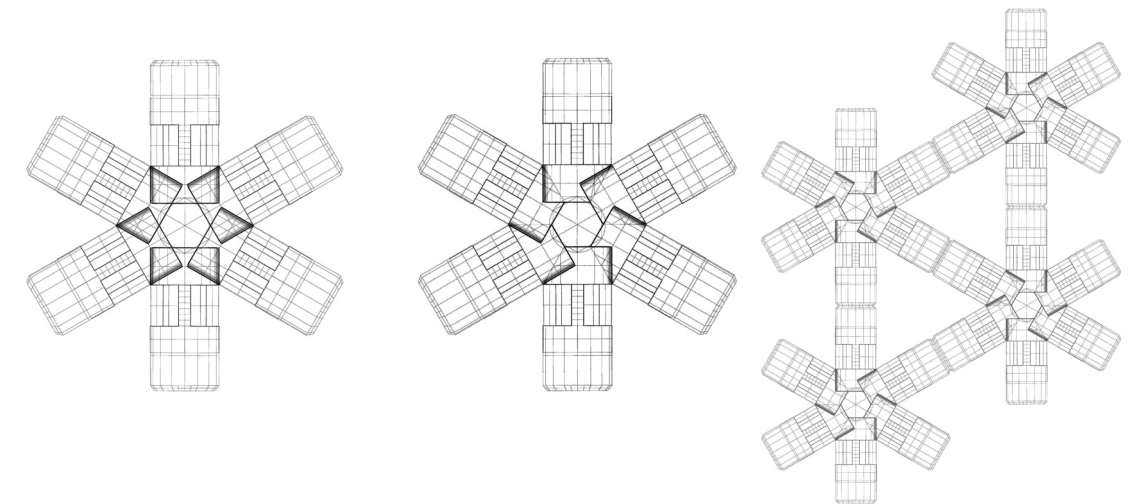

Figure 5.42: six components junction Position

Figure 5.43: six components junction Connection

Figure 5.44: six components junction Assembly

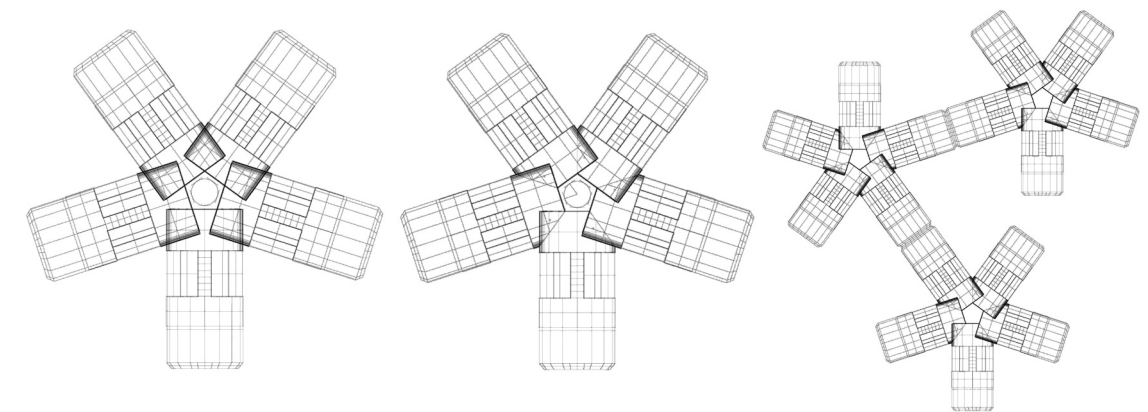

Figure 5.45: five components junction Position

Figure 5.46: five components junction Connection

Figure 5.47: five components junction Assembly

Consequently, the joint system based on pentagons that, as already stated, is the only one between the tested connections that is not tessellating in plan; was tested in the 3D environment, through the convex regular icosahedron, also simply called regular icosahedron. It is one of the five regular Platonic solids, which contains twenty triangular faces, with five faces meeting around each vertex. The structure is based on connections made of five components around each vertex and because of its regularity, allows all the connections to be the same.



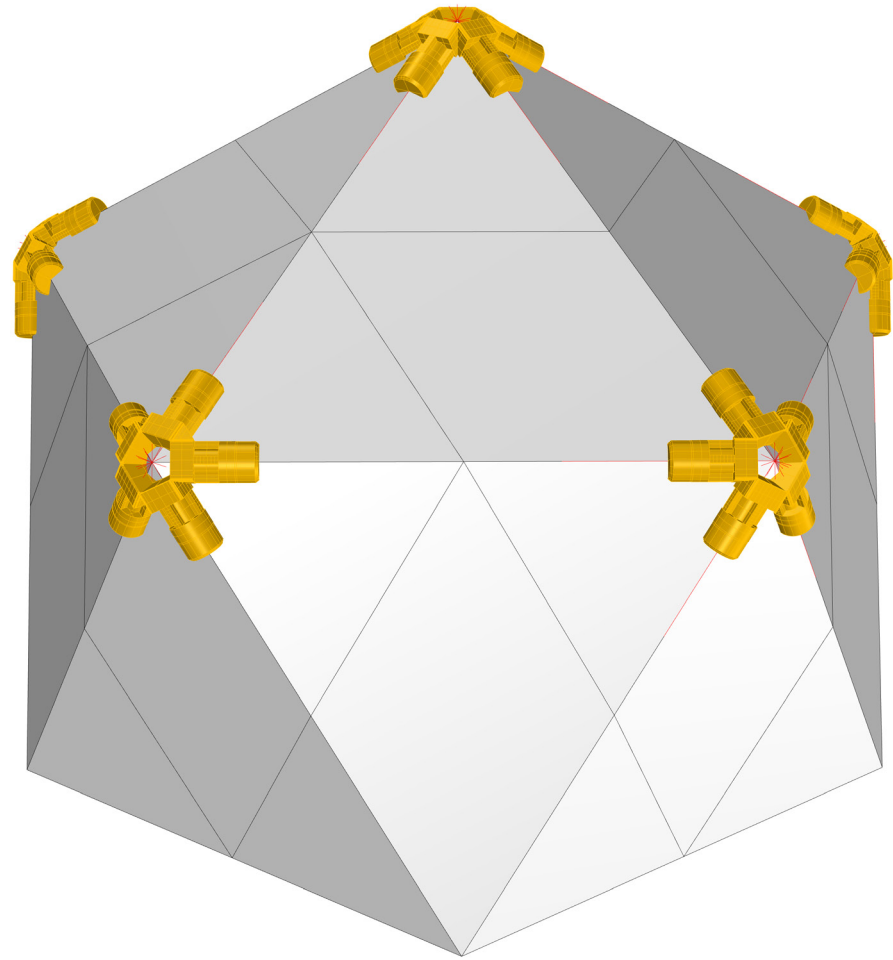

Figure 5.48: five components junctions placed on the vertex of a regular icosahedron

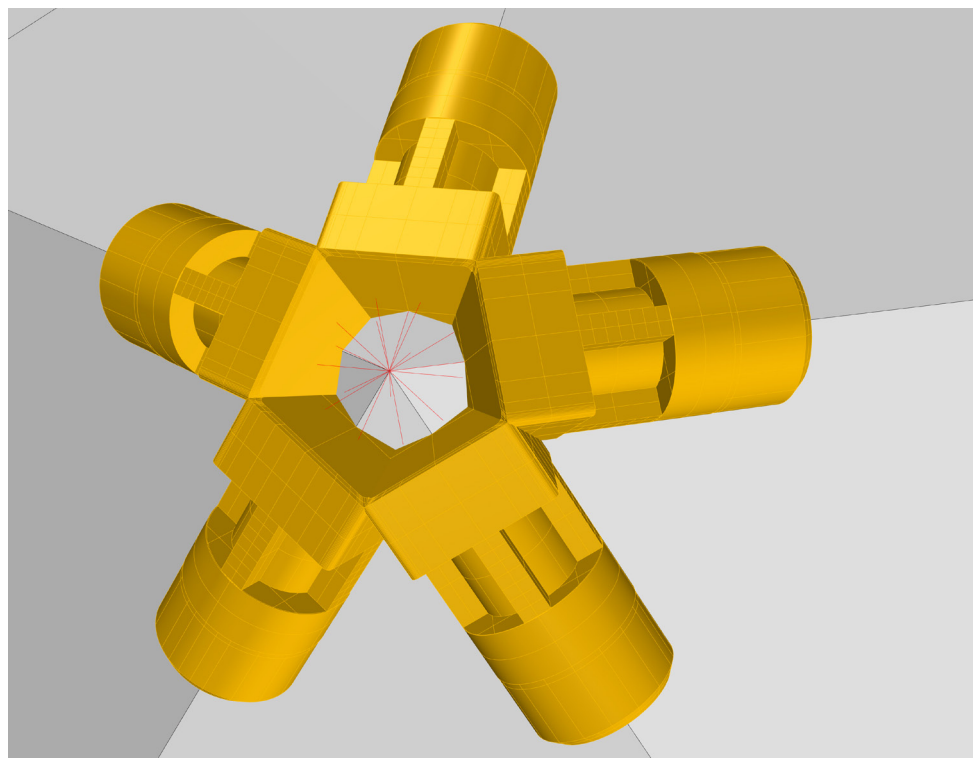

Figure 5.49: detail of the five components junction on a vertex of the regular icosahedron

## 5.3 Computational system

The role of computational design in the research is mainly related to aspects like simulation, optimization, and fabrication. In fact, thanks to digital fabrication, the limits of what is possible to achieve are changing the design potentials. The designer has now the possibility to move a step forward from traditional geometry and to achieve geometry complexity through all the scales of the design (micro-meso-macro) enhancing the performance requirements and the design accuracy of the all structure. Hence, if a digital model is optimized, is possible thanks to digital fabrication to realize a physical prototype of the exact same geometry.

Accordingly, it was ideated a script based on the idea of building a system that could tessellate every possible shape, placing the joints based on the drill container components together with the laboratory ware component, at the vertex of the tessellation. Consequently, the drill components are connected together through the water pipe component and then a plastic foil is placed over the structure.

The script is made of five main steps.

**Step 0** is the creation or selection of the surface that would serve as a starting point for the computational design of the structure, based on the needed dimensions for the structure and on the desired shape.

**Step 1** includes the tessellation of the shape, or else the subdivision of a shape in faces based on polygons. In particular were selected the hexagons because they create joints based on three components that considering the medium size of the drill components and the complexity of their intersection, results the best solution. In this step is important to select the right division of the surface in the U and V direction, which would make the hexagonal structure more or less dense. For example for the selected structure, that has dimensions around (8x4x4)m (length-width-height) it is used a surface division equal to eight for the U direction and six for the V direction. Anyway, to avoid that the components are too close to each other, it is better to avoid a surface division in the U and V direction lower than five.

**Step 2** regards the positioning of the drill container components (yellow) at the vertex of the structure, originating the first part of the joints that will also be used to connect the pipes of the ribbon structure. These first components are placed with an orientation that is perpendicular to the rib on two planes and parallel on another.

**Step 3** concerns the placing of the laboratory ware component (orange), once again at the vertex of the structure but with an orientation that is perpendicular to all the three ribs at the same time, even if they have a different direction. Moreover, to provide enough surface area for the yellow components to connect to it, the orange component is placed with its centroid corresponding to the node of the joint. Once again this component will be used another part of the structure, that is the plastic foil.

**Step 4** is the creation of the plastic pipes for the ribbon structure, connected to the top part of the yellow components on both sides. In order to extract from the script the length needed for each pipe.

**Step 5** is the last one and it is used to ww. The surfaces are going to be made of plastic foil, which will be connected to the bigger screw cap of the orange component, constructing a second layer of the structure. Therefore is possible to retrieve from the script the dimensions needed for each surface.



Figure 5.50: Step 0 - initial surface

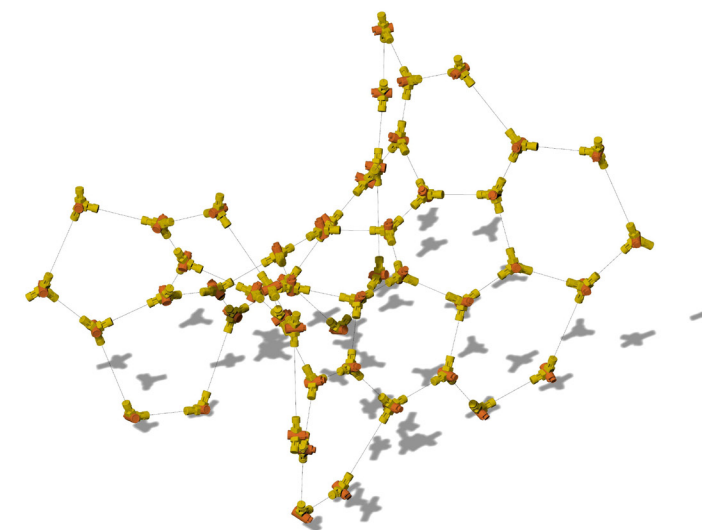

Figure 5.53: Step 3 - positioning the laboratory ware components at the vertex of the structure



Figure 5.51: Step 1 - tessellation of the shape

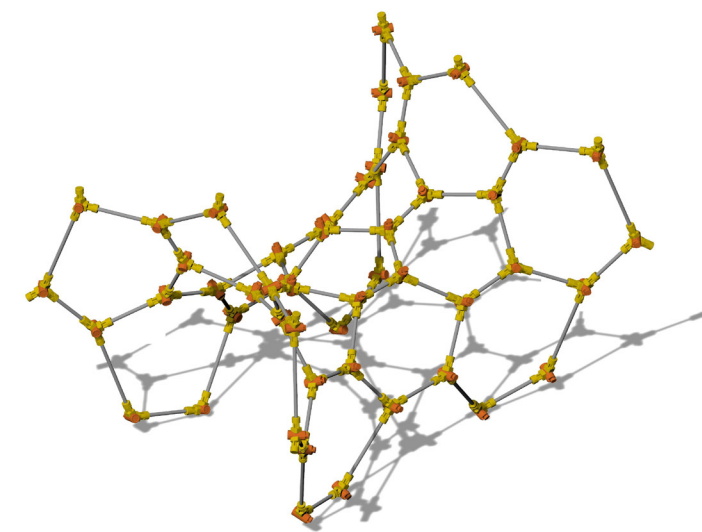

Figure 5.54: Step 4 - creation of the ribbon structure

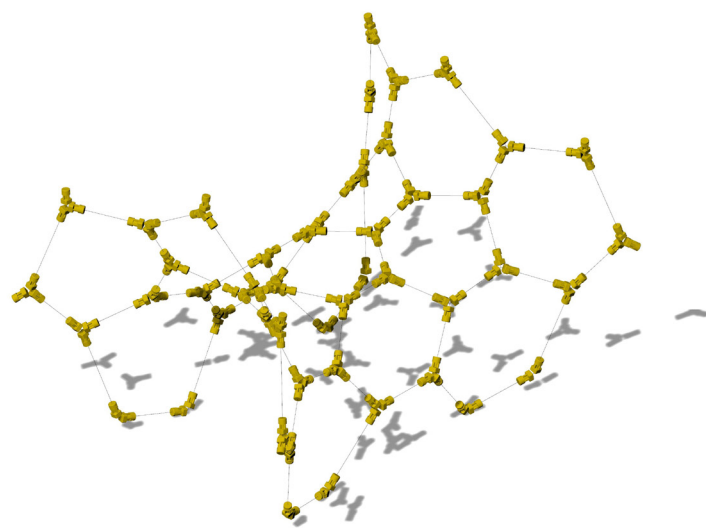

Figure 5.52: Step 2 - positioning the drill container components at the vertex of the structure

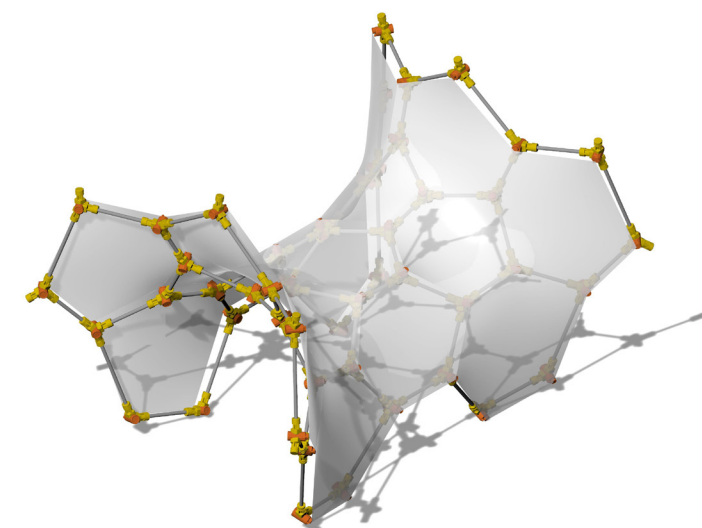

Figure 5.55: Step 5 - originating the surfaces covering every hexagon of the structure

## Possible design outcomes

Based on the computational steps showed in the previous paragraph and on the outcome of the research of possible components, three different sketch designs were elaborated to demonstrate the design potentials of the system.

The designs differ because of the different concepts used to originate them. In fact, while for the first design the structure is growing from the sides towards the center of it, in the second one the process is the opposite, so from the center, the structure is growing towards the sides. To conclude, in the third one, the shape is based on a continuous surface where there is not a start and an end.

Moreover, the designs are different because of the number of supports needed by the different structures. In fact, the first design is characterized by the use of eight support points, while in the second design the supports become four, as well as in the third.

The **first design** is based on a quadrilateral footprint, where are placed four arches in the middle of every side of the square. The arches will serve as entrances to the pavilion and the start and end point of every arch will act as a support for the all structure, therefore the pavilion is based on four arches and eight support points. Besides, starting from the basic idea of a geodesic dome, which is growing in height while reaching the center and highest point of the structure, the pavilion is as well characterized by a shape that from the sides is increasing in height towards the summit of the structure, originating a pavilion defined by a spiky shape.

The **second design** starts from the idea of realising a shape that can be repeated, in order to cover more surface area when needed. In order to do so, the roof part of the pavilion was designed as a flat surface with a support point in the middle of it, developing a form similar to the structure of a tree. However, for the pavilion to be stable, the core of the structure has a cylindrical shape where are placed four supports, from which the pavilion is growing in height, evolving in a cantilever structure.

The **third design** was generated by the tessellation of a continuous surface, standing on four support points, placed on two sides. The basic idea of the design is to put an emphasis on the entrances of the pavilion, originating a structure that is opening towards the visitor, inviting him to enter. Furthermore in this shape is particularly evident that the amount of hexagons used in the tessellation are decreasing where the curvature is lower (large radius) while they are increasing where the curvature is higher (small radius).

## First Design

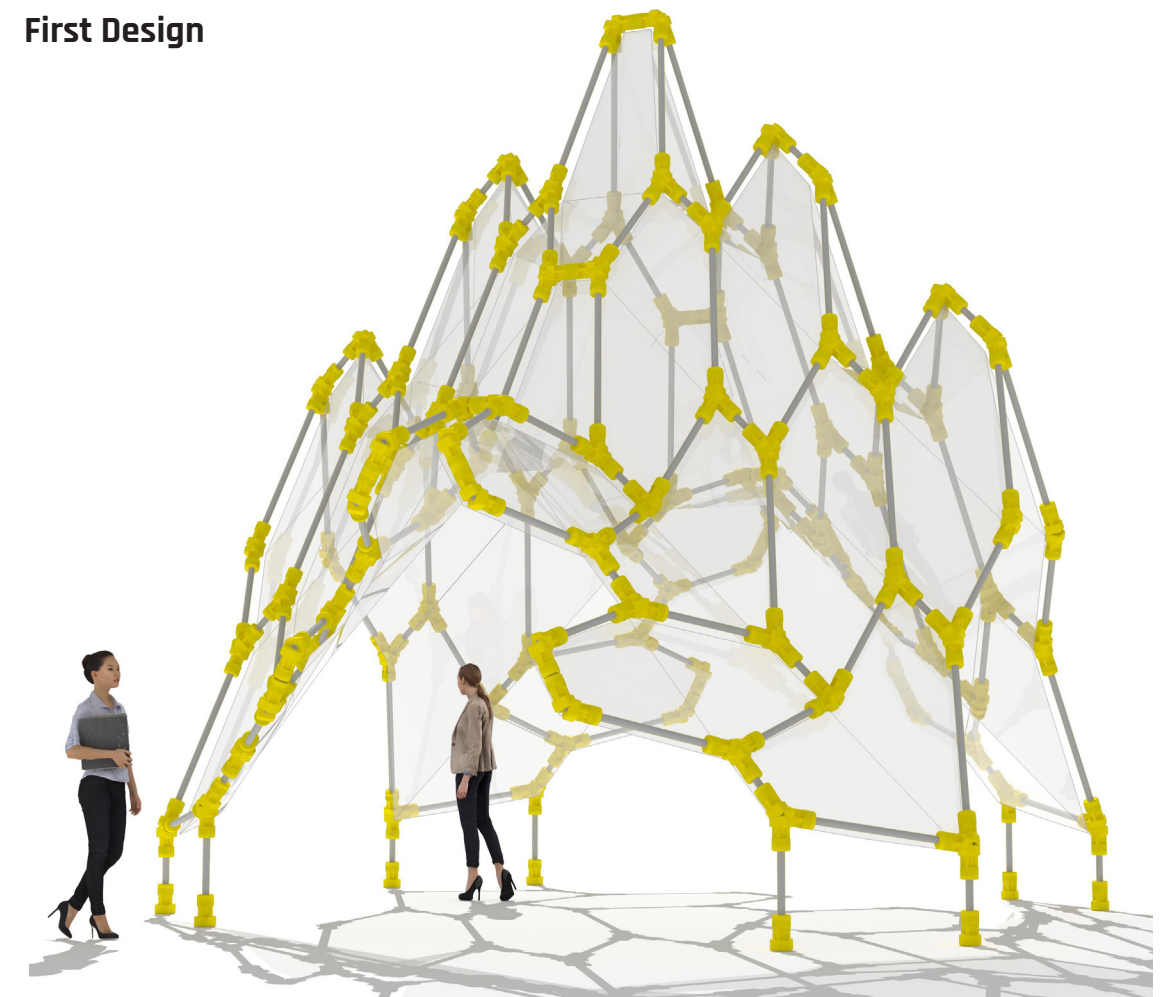

Figure 5.56: First Design - Perspective view

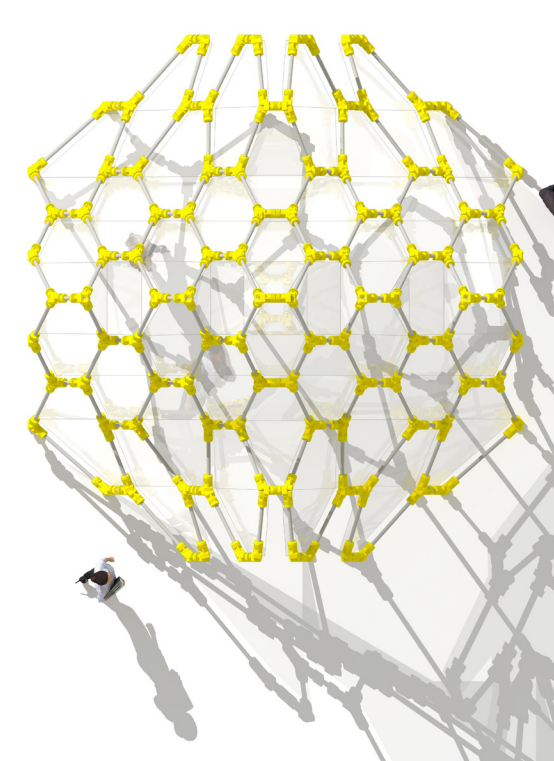

Figure 5.57: First Design - Top view

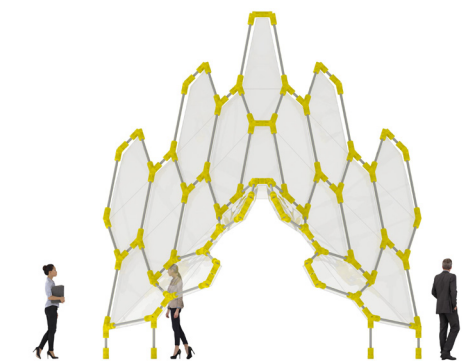

Figure 5.58: First Design - Side view

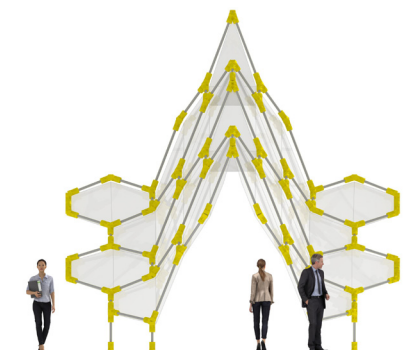

Figure 5.59: First Design - Front view



**Second Design**

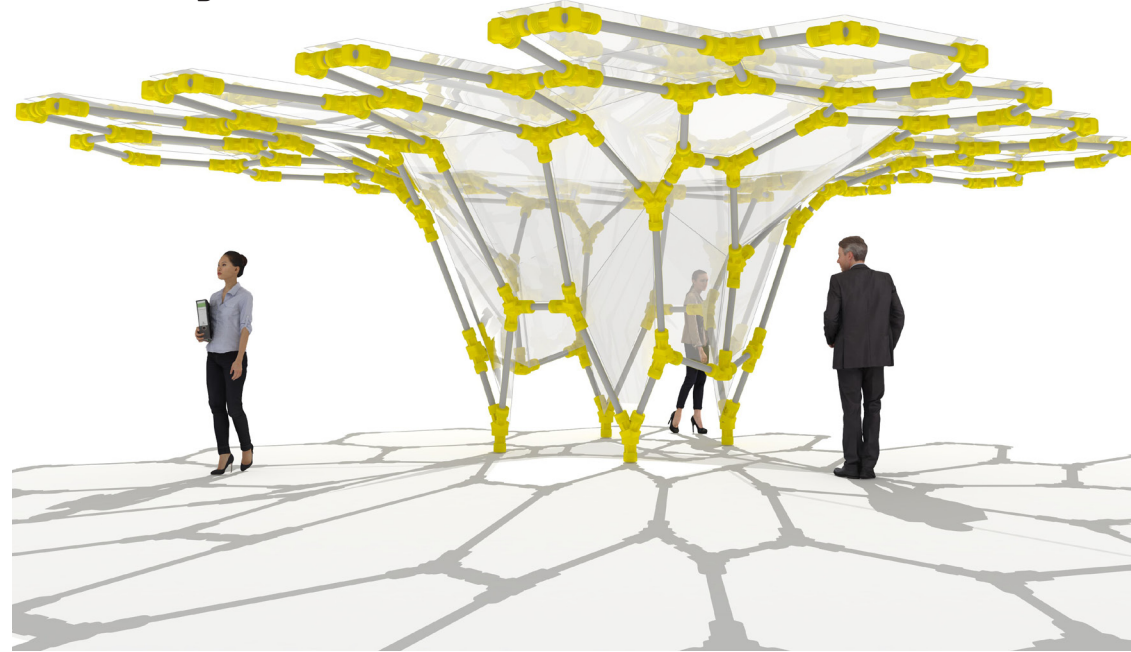

Figure 5.60: Second Design - Perspective view

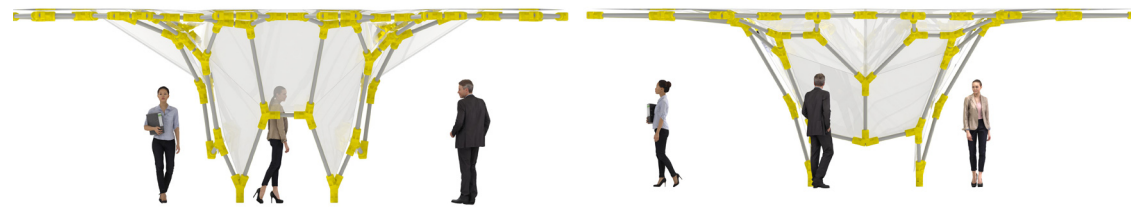

Figure 5.61: Second Design - Side view

Figure 5.62: Second design - Front view

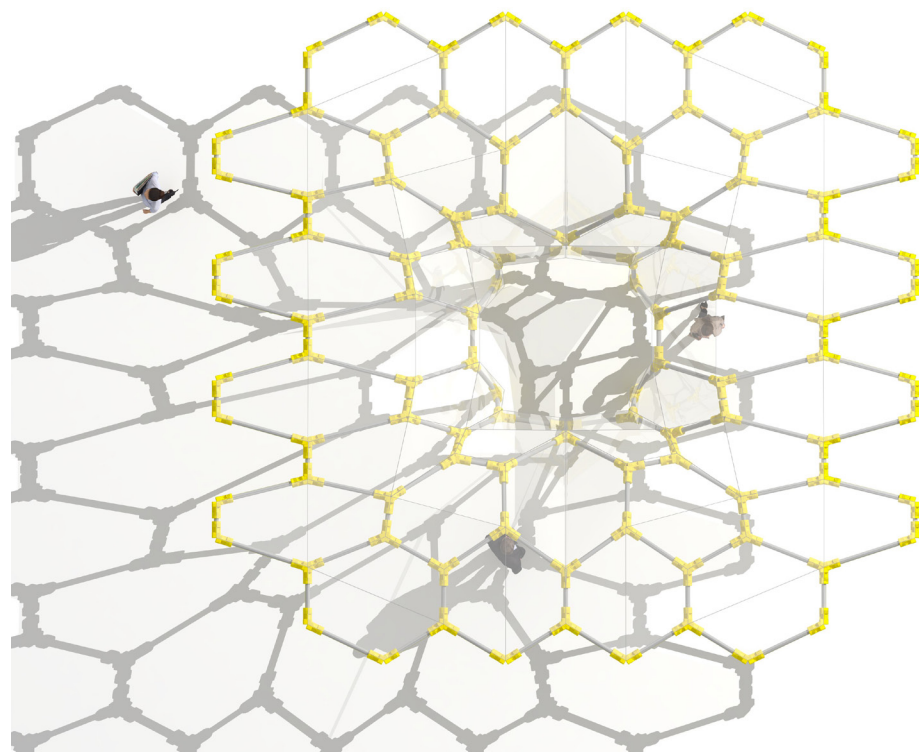

Figure 5.63: Second Design - Top view

**Third Design**

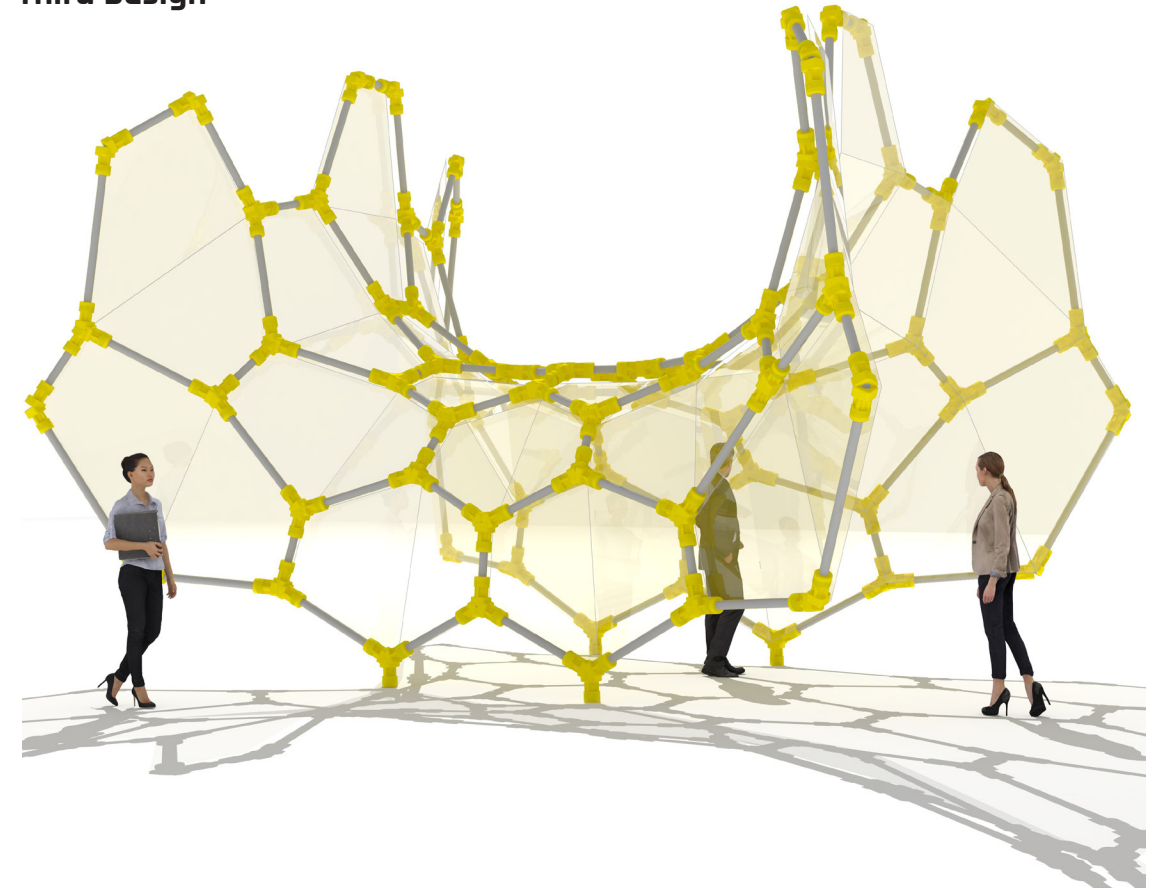

Figure 5.64: Third Design - Perspective view

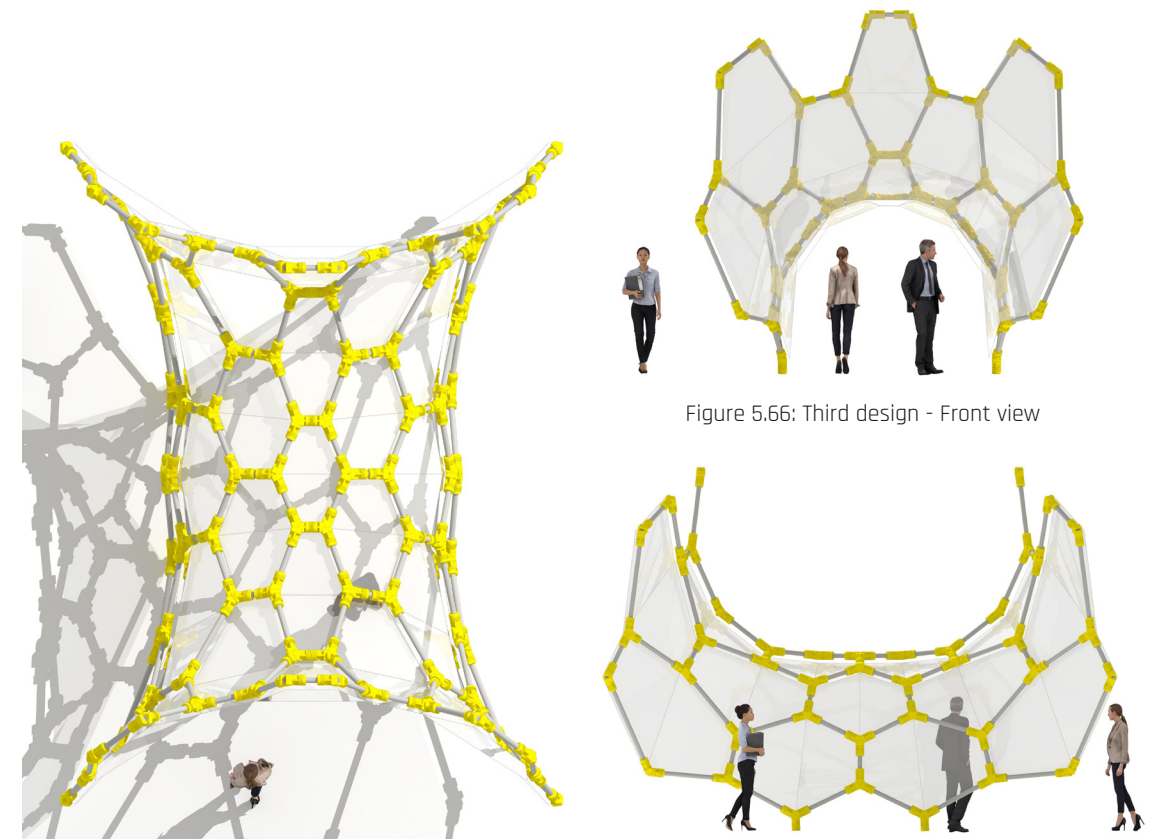

Figure 5.66: Third design - Front view

Figure 5.65 Third Design - Top view

Figure 5.67: Third Design - Side view



## Locations

In order to demonstrate once again the design potentials of the system, three possible locations on the TU Delft campus were selected, according to different requirements.

The first one is the **TU Delft Library**, which represents an indoor space and it can also be considered as a private space. In particular, at the ground floor of the Library, there is a space that is usually used for small exhibition where the pavilion could be placed to delimitate the exhibition area. Obviously according to the location where the pavilion is positioned, different requirements have to be met. In case of an indoor space, there are less requirements from a climate point of view compared to an outdoor one, but there could be limitations regarding the size of the structure as well as the general expression of the design, that has to fit with the one of the existing building.

The second one is the **Science Center courtyard**, which is a semi-outdoor space as well as a semi-public space. The building would fit with the general idea of the research because it is used to displace research projects related to technology. Regarding the requirements that the pavilion should fulfil, there would be some limitations once again in size, in this case, more from a footprint point of view than from a height point of view; instead, regarding the climate situation, the structure should fulfil some requirements such as water-tightness but it would be less exposed to the weathering.

The third location is the **Free Zone** close to the TU Delft Auditorium, which is a public outdoor space. It is generally used for events on campus, such as the International Festival of Technology or even the Introduction Program. In these events are currently used traditional tents that could be replaced with the pavilion proposed by the research project, in order to make use of a structure that, thanks to the reuse of material, gives back more to its surroundings than it takes away from it. Certainly in case of an outdoor use, there would be more requirements for the structure, in fact it should be able to withstand weathering, or even if used as a summer pavilion, should still be stable enough to withstand wind load.



Figure 5.68: Science Center

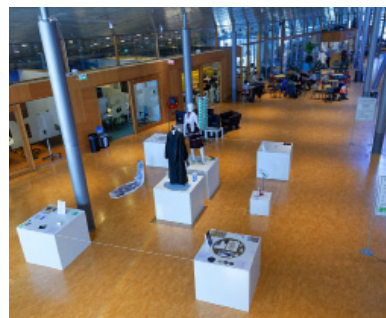

Figure 5.69: Tu Delft Library



Figure 5.70: Free Zone



Figure 5.71: Top view TU Delft Campus

## 5.4 Structural analysis

To simulate the structural behaviour of the building system described in the paragraph above, it will be run the structure analysis on one of the research design. The structure will be analysed in Karamba, a parametric engineering software used to provide analysis of wireframe structures. In fact, to run the structural analysis, the structure of the pavilion needs to be approximated to a wireframe structure subjected only by gravity load.

The wireframe structure is analysed as a set of beam elements, which meet at common points creating rigid connections. Therefore, the joint element will be discarded in the model and it will be substitute by a rigid connection. Moreover, the four nodes where the pavilion is connected to the ground are modelled as fixed wall supports. Although the joint elements connected to the ground are not fully stiff, it is reasonable to assume that they will behave more like fixed-end ones, suppressing both translations and rotations at the nodes.

In reality, any structure has to provide for adequate strength, stiffness and stability for it to remain safe and usable. Regarding the strength of our structure, the ultimate and allowable stresses are of importance. Therefore, it was evaluated the normal force in every beam to compute the values of the maximum compression force and the maximum tension force and compare them with the values of the compressive strength and tensile strength of the PE-HD (Polyethylene, high density); material that forms the joint element.

On this purpose, after defining the elements, in this case the beams, their material should be defined. It is possible to do so in Karamba specifying the mechanical properties of the material. The latter were retrieved from CES Edupack 2018, a comprehensive database of materials where it was possible to find all the information needed for the material (Appendix B).

To define further the elements for the analysis, the cross section of the beams was specified. It consist in a hollow circular cross section with a thickness of 3mm and diameter of 50mm; measures that corresponds with the ones of the water pipes used for the ribbon structure.

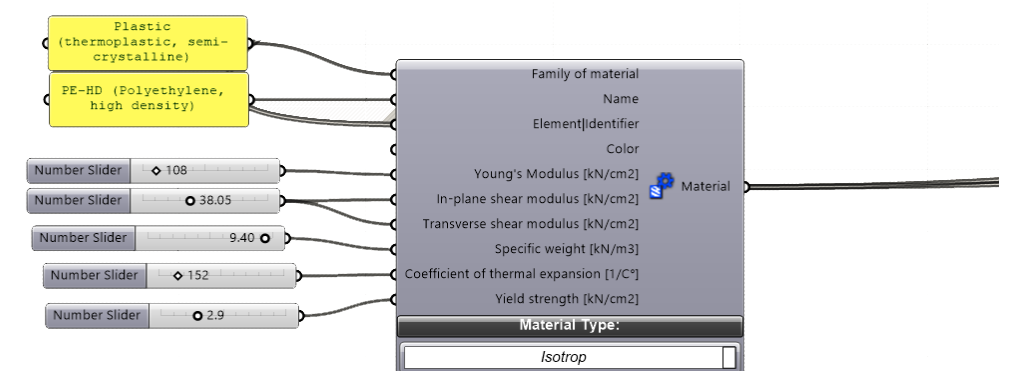

Figure 5.72: Karamba - mechanical properties of the material



Thus, after the model is assembled, it can be analysed. Hence, it is important to consider the utilization of every element or beam in the structure. In particular, the utilization in Karamba refers to the ratio between the normal stress and the yield stress of the corresponding material, whereas shear and buckling are not considered. In the structure analysed the maximum utilization for compression is equal to 15% (displayed in red) and for tension to 14.5% (displayed in blue), therefore it is possible to affirm that the utilization of the beams is acceptable, in fact for safety rules, the values should always be under 70%.

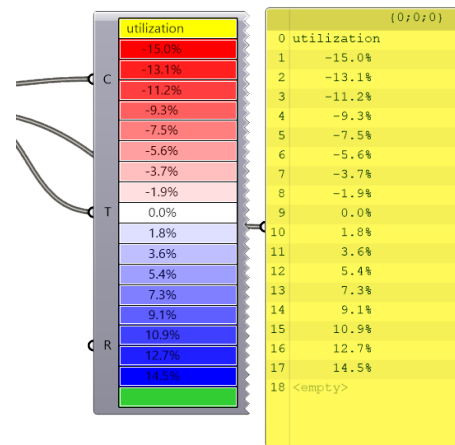

Figure 5.73: Karamba - utilization of the structure

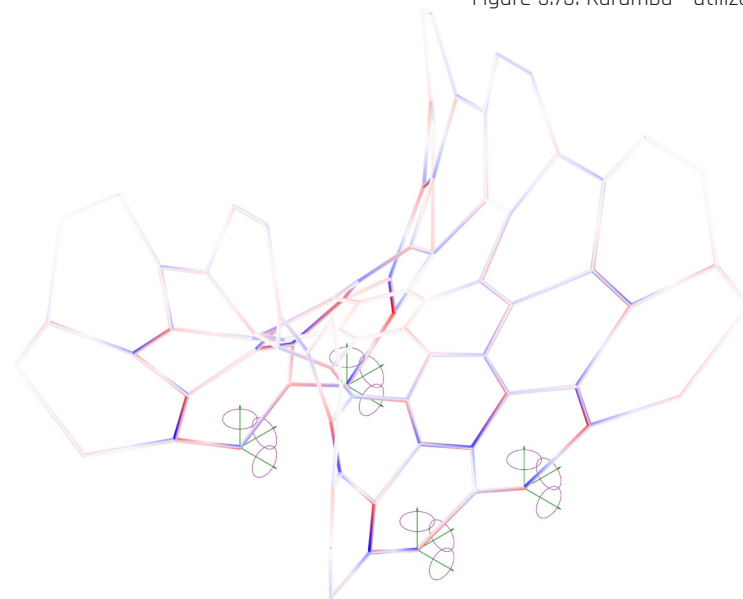

Figure 5.74: Karamba - utilization of the structure and position of the supports

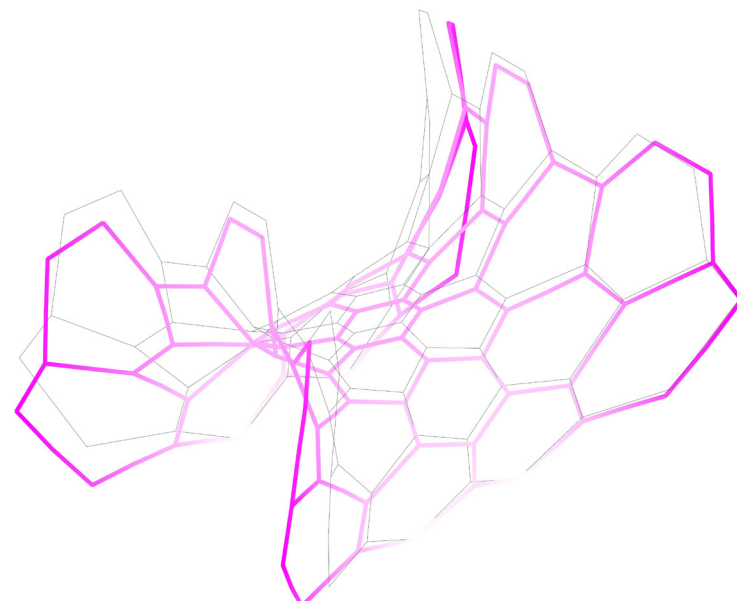

Figure 5.75: Karamba - maximum deformation of the structure

The analysis component used in the script follows the first order theory, so assumes that the influence of axial forces is negligible. Accordingly, thanks to the analysis of the model it is possible to retrieve axial forces N, resultant bending moments M and shear forces V for all beams in order to extract the values of the maximum compression force and tension force in the structure.

The analysis determined a **maximum compression force of 0.077428 KN** and a **maximum tension force of 0.033982 KN**. In order to confront these values with the compressive strength and tensile strength of the material, it is necessary to convert the values into N/ mm<sup>2</sup>; in fact, the above-mentioned values of the material are in MPa that corresponds to N/ mm<sup>2</sup>.

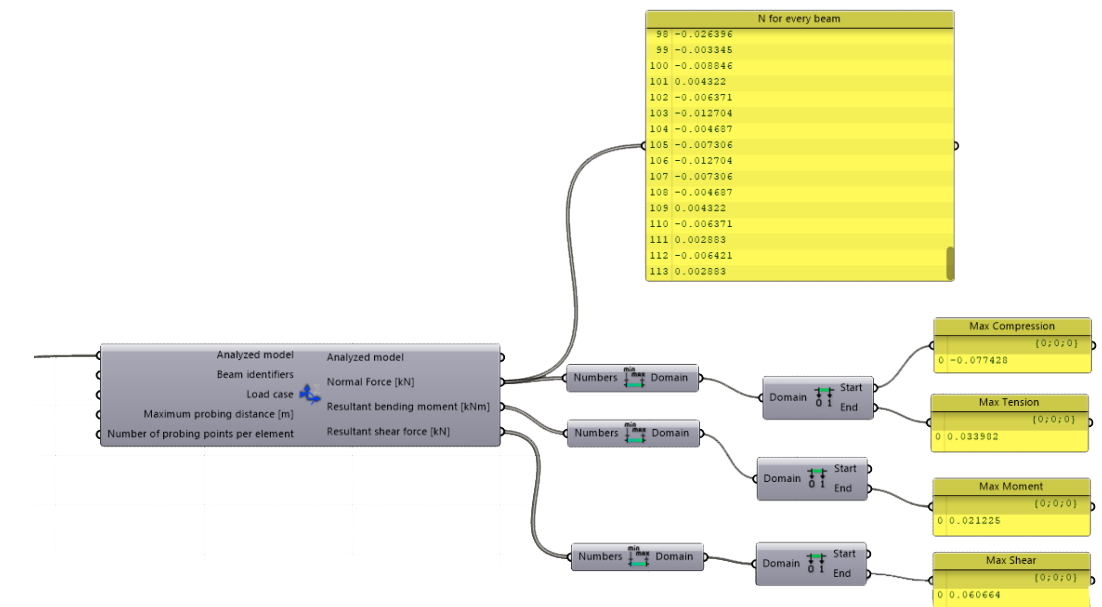

Figure 5.76: Karamba - analysis of the structure according to the first order theory

To conclude, it is possible to convert the values obtained by the structural analysis, dividing the maximum compression force and the maximum tension force, with the Area of the cross section of the pipe. Consequently, we can write that:

$$\begin{aligned} \text{Area circle} &= \text{pigrco} \times r^2 \\ \text{Atot} &= \text{pigrco} \times (25)^2 = 1963.495 \text{ mm}^2 \\ \text{Ainside} &= \text{pigrco} \times (22)^2 = 1520.530 \text{ mm}^2 \\ \text{Area cross section pipe: } \text{Atot} - \text{Ainside} &= 1963.495 \text{ mm}^2 - 1520.530 \text{ mm}^2 = 442.965 \text{ mm}^2 \\ \text{MPa} &= \text{N/mm}^2 \end{aligned}$$

**COMPRESSION:**

PE-HD Compressive strength = 18.6 MPa - 24.8 MPa = (18.6 + 24.8) MPa / 2 = 21.7 MPa (average value)

$$F/A = 77.428 \text{ N} / 442.965 \text{ mm}^2 = \mathbf{0.18 \text{ N/ mm}^2} < \mathbf{21.7 \text{ N/ mm}^2}$$

**TENSION:**

PE-HD Tensile strength = 22.1 MPa - 31 MPa = (22.1 + 31) MPa / 2 = 26.55 MPa (average value)

$$F/A = 33.982 \text{ N} / 442.965 \text{ mm}^2 = \mathbf{0.076 \text{ N/ mm}^2} < \mathbf{26.55 \text{ N/ mm}^2}$$

## 5.5 Design-to-Robotic-Production

### Robotics in Architecture

Experimentation with robotics in architecture started with the use of animation software for design and later on the move was made from animation to scripting. Together with the use of scripting tools for procedural modeling, it started also to grow an interest towards form generation and digital fabrication. In fact, industrial robots are not new but have been in existence since the 1954 Ultimate, and the 1969 six-axis Stanford arm with computer controlled electronic movement (Testa P., 2017).

Moreover, robots have been used since the 70s for many manufacturing processes but only lately universities started to recognize their potential, exploring their application in architecture. Nowadays many academies are engaging industrial robots for the production of 1:1 prototype of building components, which will be integrated into buildings that are still designed and constructed in a traditional way.

Instead, D2RP aims to integrate robotic production in the building industry, individuating where is needed from the early stage of the design. Indeed D2RP facilitate the creation of a feedback loop between the digital design and the 1:1 scale prototype; starting from the already optimized digital model, it is possible to convert the design into robotic tool path to add, cut out or transform a material so as the researched design can be physically visualized.

### Starting Points

The most important aspect of the research is the study of the joints based on the reused plastic component, therefore it was important, starting from the design of one of the joints originated by the script, to study the connection of the components between each other; therefore many options were considered.

The first and more obvious one was welding, that being a thermal process, in the case of plastic could lead to cracking or shrinking of the components. Therefore, similar options that do not require a thermal process were considered, such as solvent bonding, the use of an adhesive connection or glue.

It was also possible to perform a mechanical connection, for example using an L shape element and connecting the pieces with bolts, using tie wraps after drilling the holes; or was even considered to place a vacuum bag around the components forming the joint.

At the end, the best option seemed the use of a mechanical connection based on the idea of removing and folding parts and connecting them through nuts and bolts. In fact it would avoid the use of extra material, using the interlocking parts, otherwise removed, as a connection. The main idea was, for every component, to cut one side of the interlocking part and to fold the other. In a way that the folded part of one component would fit perfectly into the cut part of another component, working as a connection, secured then by nut and bolt.

Moreover, thanks to the robot, the component can be cut at a specific optimum angle in an extremely precise and accurate way, and thanks to the script, it is possible to apply this connection system based on recycled components for a wide range of complex geometry. However, just for the complexity of the geometry, all the components that form the connections need to be custom cut at a specific angle, thus the use of robotic fabrication will make the process more accurate and faster compared to traditional methods.

### First Test

The first D2RP test was conducted on the 05.02.19 in the The Sandbox, the Lab for collaborative innovations of The Faculty of Architecture and the Built Environment at TU Delft, precisely in the Robotic Building Lab.

The test regarded the robotic removal of a part of the component, in order to create a space to interlock (or fit) the components into one another. It was executed with a 6mm drill bit and the component was fixed to the cutting table (Figure 5.77) with four bolts. However the test wasn't really successful, in fact it was visible right away that the 6mm drill bit was too thick compared to the wall thickness of the component that is only 1mm. Moreover, a construction was needed to keep the component in place while cutting, to avoid vibration.

Therefore, it was ordered a 3mm drill bit and it was made a simple but efficient construction to keep the component in place while cutting or drilling. These, were the starting points of the D2RP and they will remain crucial for all the following tests.

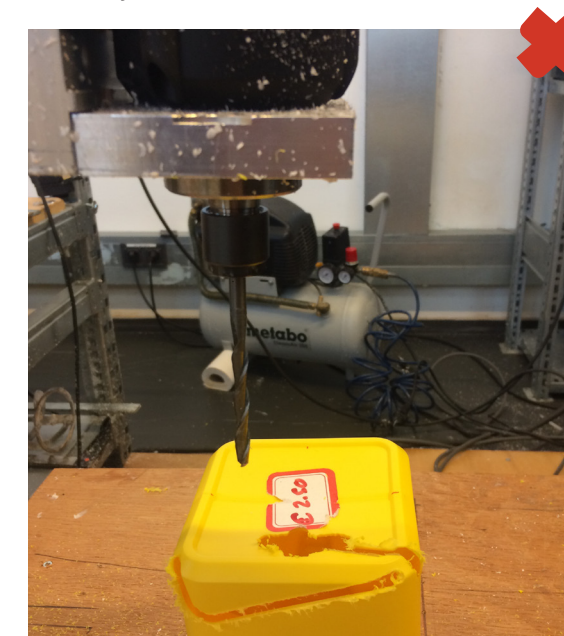

Figure 5.77: first test - 6 mm drill bit



Figure 5.78: second test - 3 mm drill bit

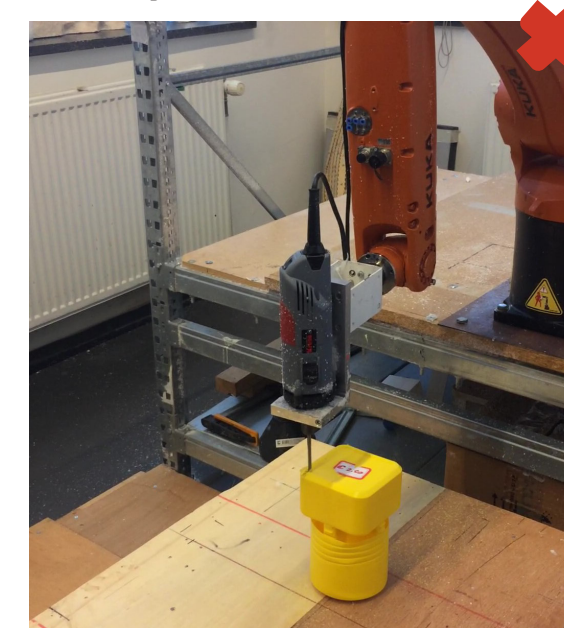

Figure 5.79: first test - no boundaries

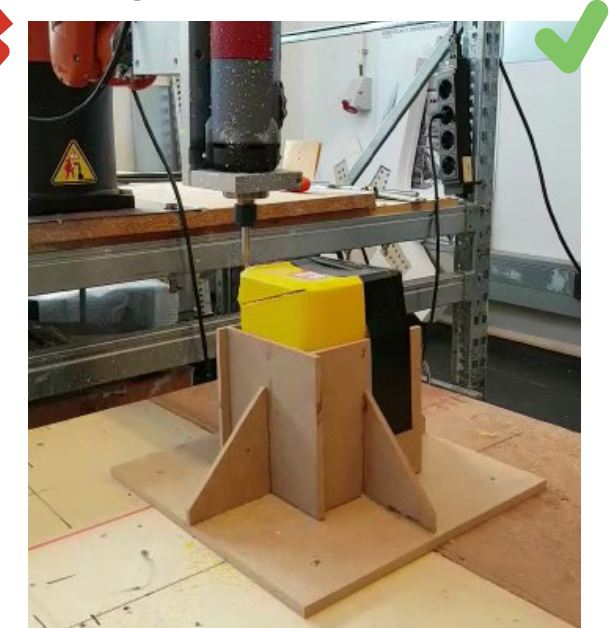

Figure 5.80: second test - construction to keep the component in place



## Second Test - First Prototype

In the second test, together with the practical improvements mentioned above, it was also improved the computational strategy. In fact the script used to simulate the removal of the material and drilling of the holes is based on the idea cutting with the robot always perpendicular to the surface, reason why the curves that delimitate the boundaries of every cut were divided in parts according to the different planes (xy-xz-yz) they are in. The different "parts" of the cut are then merged together to originate two Kuka codes, one for the removal part and one for the folding part.

The workflow of the second test was based on three steps:

**STEP 1- CUTTING** | drilling holes & material removal

**STEP 2- FOLDING** | folding parts with an utility knife

**STEP 3- CONNECTING** | connecting parts with 4mm nut&bolt

The first step is based on the drilling of the holes that will be used for the connections, that needs to be done at the beginning of the process, and then on the removal of the material where the components are intersecting each other. As already stated above, for every component one side of the intersecting part will be removed and the other will be cut in a way to be folded into the next component and used as a connection (Figure 5.83 and Figure 5.84).

The second step regards the folding of the intersecting parts discarded in the first step, used then to connect the components together. The process of folding the piece of material was done with an utility knife in order to bend the material more easily but the folded line resulted to be quite fragile (Figure 5.85 and Figure 5.86).

The third step is the connection of the components between each other, thanks to the use of a 4mm nut and bolt; more precisely 2 bolts were used per every connecting piece to ensure a safer connection (Figure 5.87 and Figure 5.88).

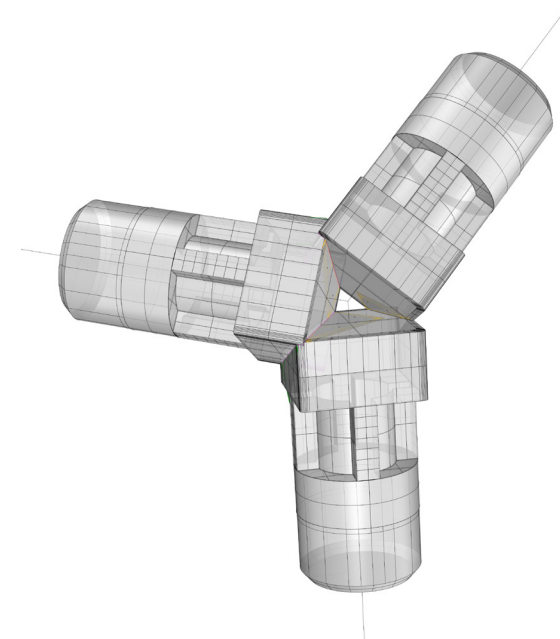

Figure 5.81: First Prototype - 3D Model



Figure 5.82: First Prototype - Prototype

## SIMULATION

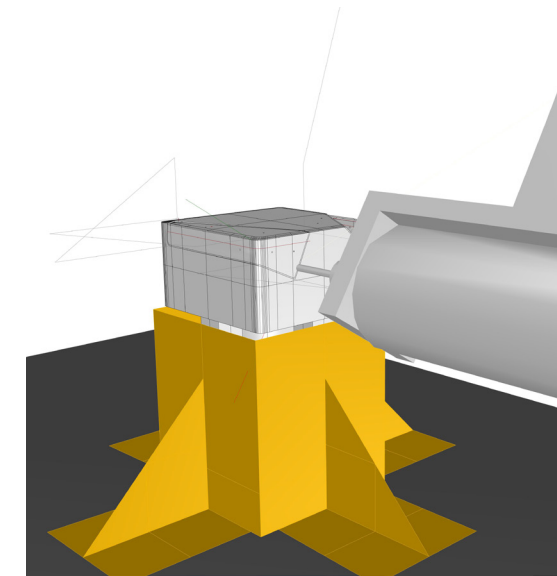

Figure 5.83: second test - STEP 1

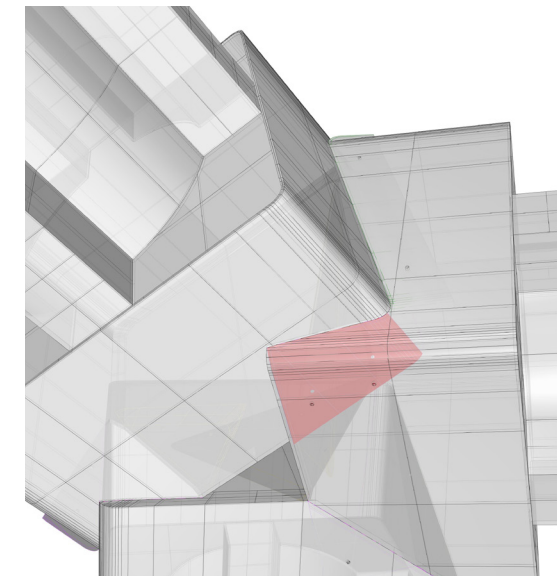

Figure 5.85: second test - STEP 2

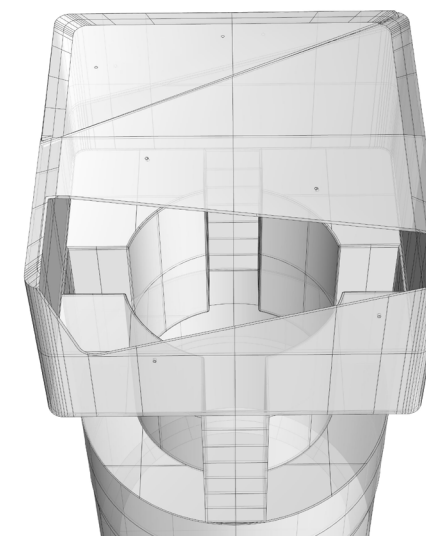

Figure 5.87: second test - STEP 3

## REAL ENVIRONMENT

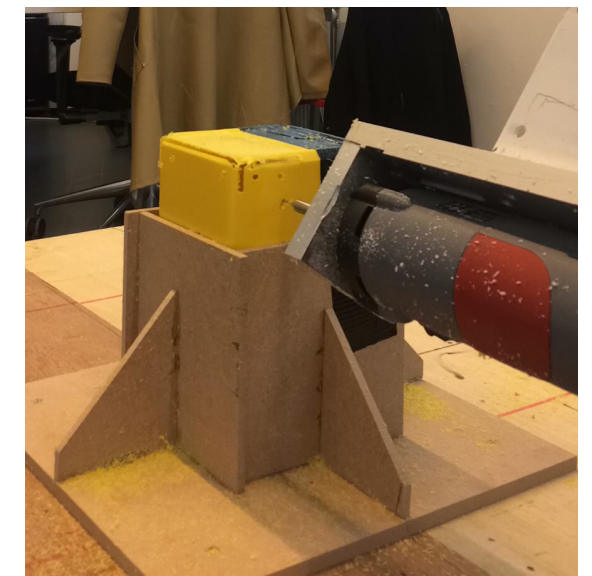

Figure 5.84: second test - STEP 1



Figure 5.86: second test - STEP 2



Figure 5.88: second test - STEP 3

## From First to Second Prototype

### Results and adjustments

The production of the second prototype was much faster than the production of the first one, thanks to some adjustment made. First, it was evident during the second test that the 3D model of the plastic component made with a series of dimensions estimated with a measuring tape, was not accurate enough. In fact, multiple times during the realization of the first prototype, some adjustments in the simulation resulted necessary to match it with what was happening in the real environment. Namely, the curves of the robotic tool path were sometimes out of position of a couple of centimetres, which in such a precise process, imply that the three components of the joint will not fit perfectly together. Therefore, during the process of material removal with the Kuka robot, many adjustments were necessary and the process became much slower. A clear example is visible in Figure 5.89 and Figure 5.90, where the curve of the cut results much closer to the drilled holes in the real environment, than what is possible to observe in the simulation.

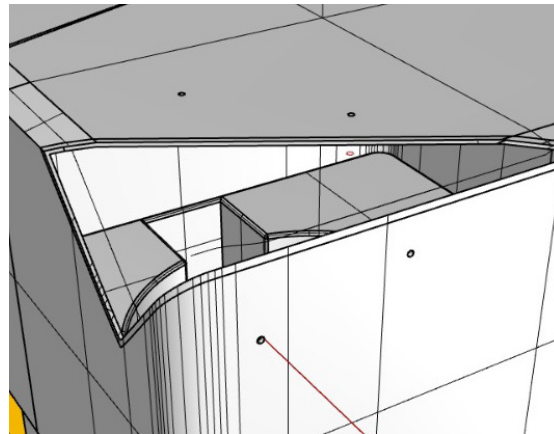

Figure 5.89: second test - Simulation of the robotic tool path



Figure 5.90: second test - Real environment with curve and holes out of position

Thus it was clear that to reach a higher level of accuracy in the 3D model, and have a better approximation of the real object, it was necessary the use of a 3D scanner.

The latter was unfortunately not available at The Faculty of Architecture and the Built Environment at TU Delft so it was used the Artec EVA 3D-scanner, a handheld 3D scanner that makes accurate 3D models of medium-sized objects, at the Royal Academy of Art in The Hague ( see chapter 5.6 3D Scanning). Consequently, the fabrication process of the single components for the joint became much faster and optimized.

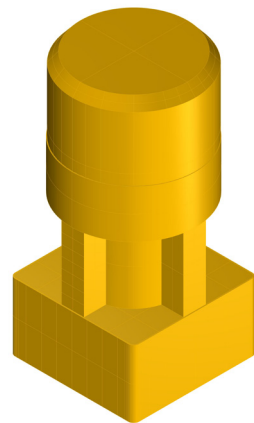

Figure 5.91: second test - 3D model

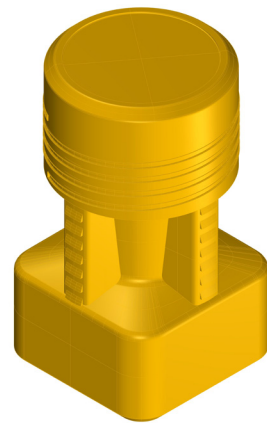

Figure 5.92: third test - 3D scan

The second adjustment regarded the distance from the base of the component to the vertex of the joint. In fact, in the first prototype the distance was 2cm, while for the second prototype the three components were pulled closer together in order to decrease the space in between them and increase the surface of contact, with the aim of making the three components behave like one element.

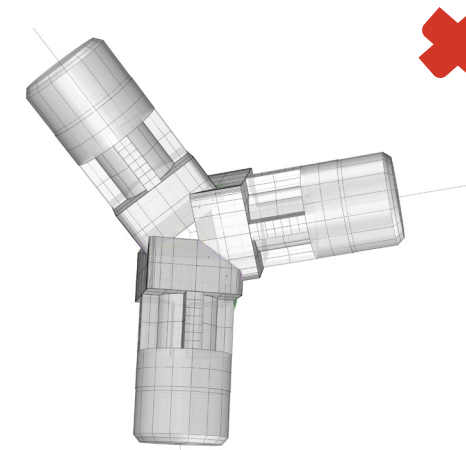

Figure 5.93: second test - 2 cm from the vertex

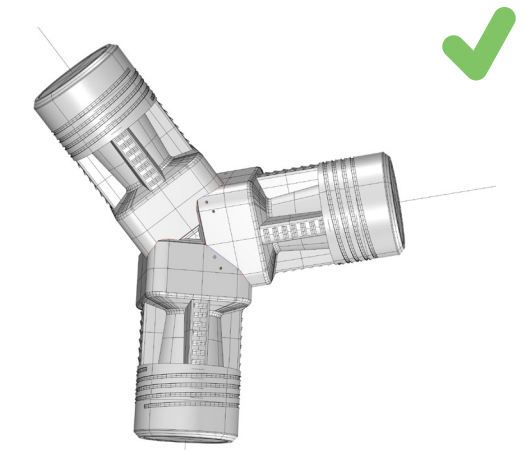

Figure 5.94: third test - 1.5 cm from the vertex

The third adjustment concerns the folding parts of the component. Indeed, while in the first prototype the robotic toolpath was only about the removal of the intersecting parts of material, on one side, and its division in parts, in order to use the material as connecting surface, on the other side.

Instead, for the second prototype the folding process was examined with more attention in favour of keeping only the parts of the material that results not difficult to fold, removing the rest (Figure 5.95 and Figure 5.96).

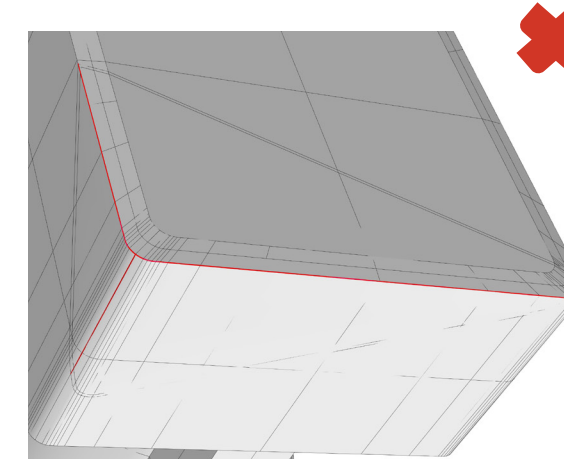

Figure 5.95: second test - folding all the material

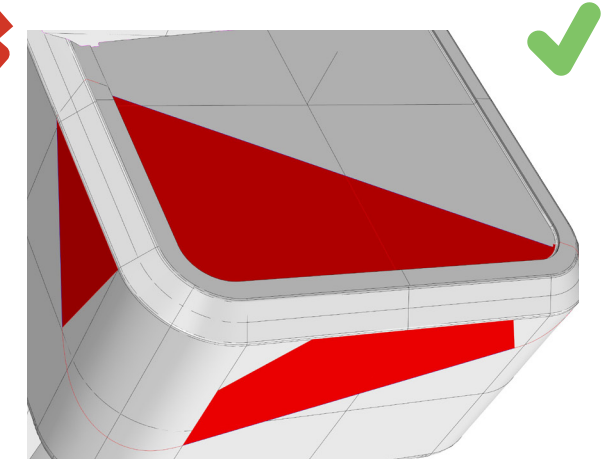

Figure 5.96: third test -folding only parts



### Third test - Second Prototype

In the second prototype, together with the adjustments mentioned in the chapter above, also the workflow of the fabrication had some adjustments.

The workflow of the second prototype was based on four steps:

**STEP 1- CUTTING** | drilling holes & material removal

**STEP 2- FOLDING** | folding parts with an heat gun

**STEP 3- WASHERS** | gluing the washers

**STEP 4- RIVETS** | connecting parts with rivets & pop rivet gun

The first step remained the same compared to the previous test; that is the drilling of the holes that will be used for the connections and the removal of the material where the components are intersecting each other.

About the second step, the concept of using a part of material that should be removed as connection element staid the same but it changed the method to fold the material. As a matter of fact, while in the first prototype the material was folded with an utility knife, for the second one it was used an heat gun; namely the GAMMA hot air gun HG-2000E, that is continuously adjustable with steps from 10 ° C to a maximum of 650 ° C. It was used at a fixed temperature of 230° C for 1 or 2 minutes.



Figure 5.97: third test - STEP 1 | drilling holes & material removal

The process contemplates the positioning of two pieces of wood on top and bottom of the folding line, in order to heat only the portion of material needed. Afterwards the pieces of wood were fixed with clamps and the heat gun was moved along the folding line for one or two minutes, until the plastic starts to become malleable and easy to fold without cracks. The folded piece is then kept in the desired position for some minutes until the plastic dries and the material is definitely bent.

The third step became necessary when from nut and bolt, used in the first prototype, it was decided to use rivets, in order to make easier the process of assembling of the components. Actually thanks to the use of the pop rivet gun, the connections can be fastened only from the outside without the necessity of inserting a nut from the inside of the component.

However, the pressure applied by the pop rivet gun into the plastic surface of the component caused the expansion of the holes in the plastic, because of the difference in yield strength between the plastic component and the aluminium rivet. Therefore it was necessary to provide more connection surface around the holes, to avoid that the rivets become loose and fall off. Accordingly, two washers were glued on the surface around each hole, one per side (exterior-interior).

After that the washers were glued and the glue dried, the components were connected together to form the joint, using two rivets per connecting surface.



Figure 5.98: third test - STEP 2 | folding parts with an heat gun



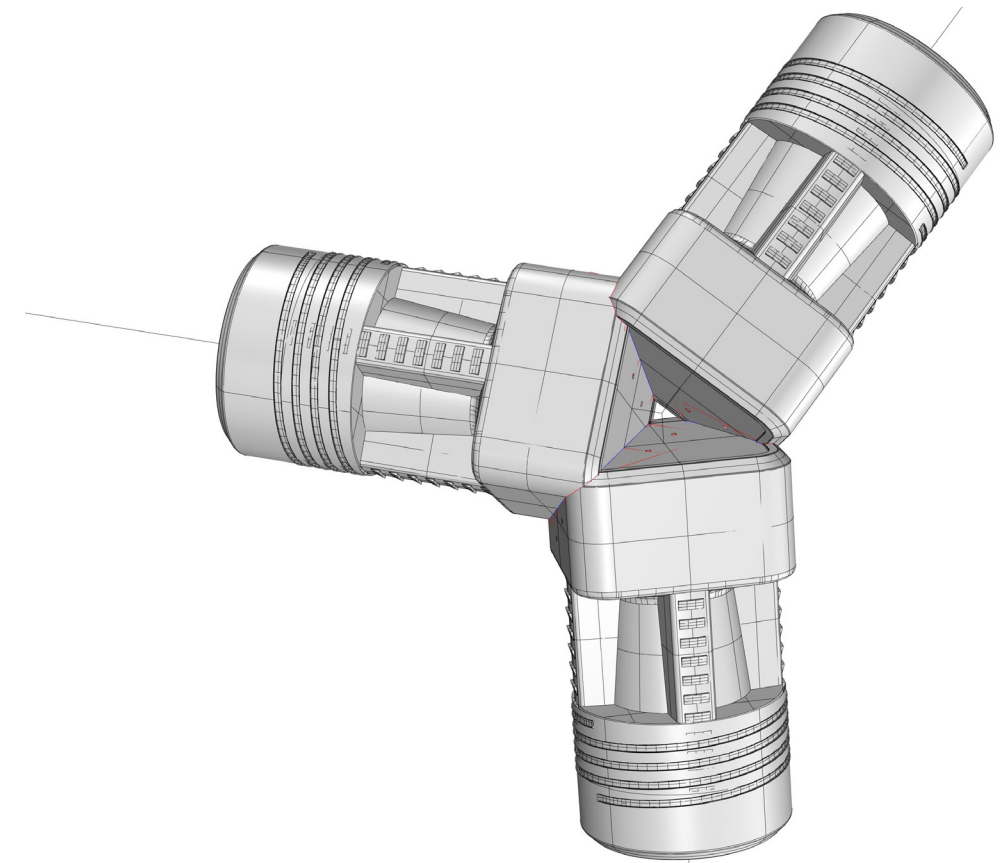
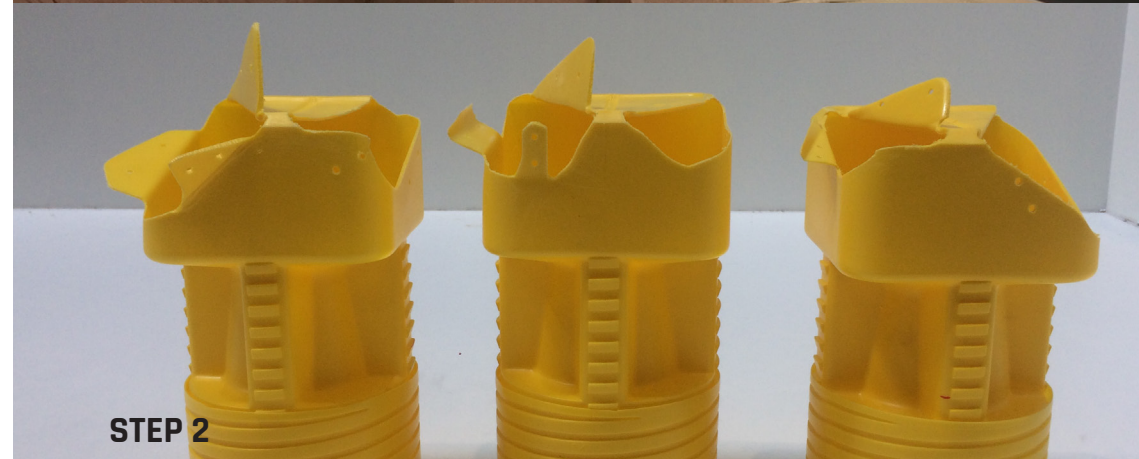

Figure 5.99: third test - Second Prototype I 3D model



Figure 5.100: third test - Second Prototype I Prototype



## Fourth test - Third Prototype

In the third prototype was introduced a fourth component to the joint, the Kima disposable laboratory ware, that would act as core of the joint and it will serve as a connection to the membrane of the pavilion, while the drill container components will act as connection to the wireframe structure, namely the PVC pipes.

The workflow of the third prototype was based on five steps:

**STEP 1- CUTTING** | drilling holes & material removal lateral components

**STEP 2- CUTTING** | drilling holes & material removal central component

**STEP 3- FOLDING** | folding parts of the lateral components with an heat gun

**STEP 4- WASHERS** | gluing the washers

**STEP 5- RIVETS** | connecting with rivets

The process of the first step remained similar to the previous tests. In fact, once again it regards the drilling of the holes that will be used for the connections and the removal of the material from the drill container components, saving only some parts of them to use as connection elements to the Kima component.

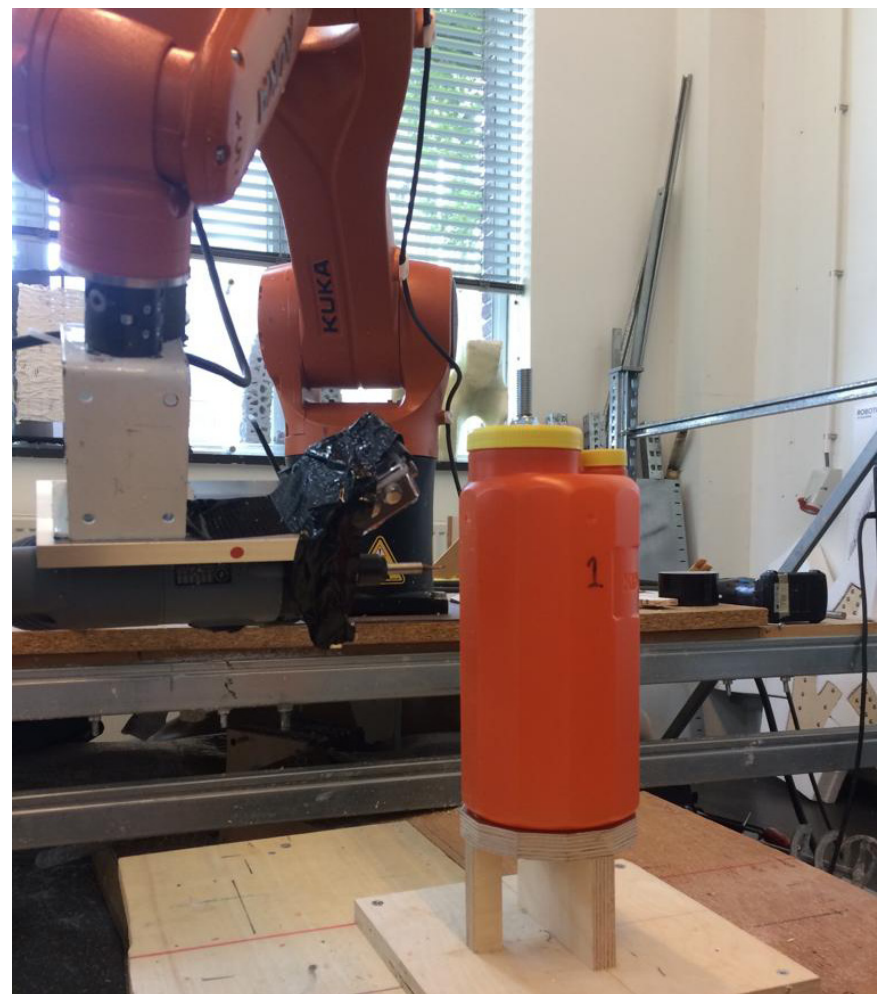

Figure 5.101: fourth test - STEP 2 | drilling holes & material removal

The second step concerns the cutting of the central component, or Kima laboratory ware. In this case, small sections of the components are removed, in order to create rectangular openings in the geometry, openings that will be used to insert the folded surface of the lateral components (Figure 5.102).

The third step remained the same compared to the previous test; actually, the parts of intersecting surface saved in the first step are used then to connect the lateral components to the central one. Therefore as in the previous test, a heat gun is used to fold the material to the desired angle in order to bend it, creating two parallel surfaces, ready to be connected.

Therefore, the washers were glued around every connecting hole, in order to avoid the presence of excessive pressure and localized stress in the plastic, which would make the connection with the rivets, ineffective.

Consequently, the lateral components were connected to the central one, one at a time, inserting the folded piece of material into the rectangular openings already milled in the central

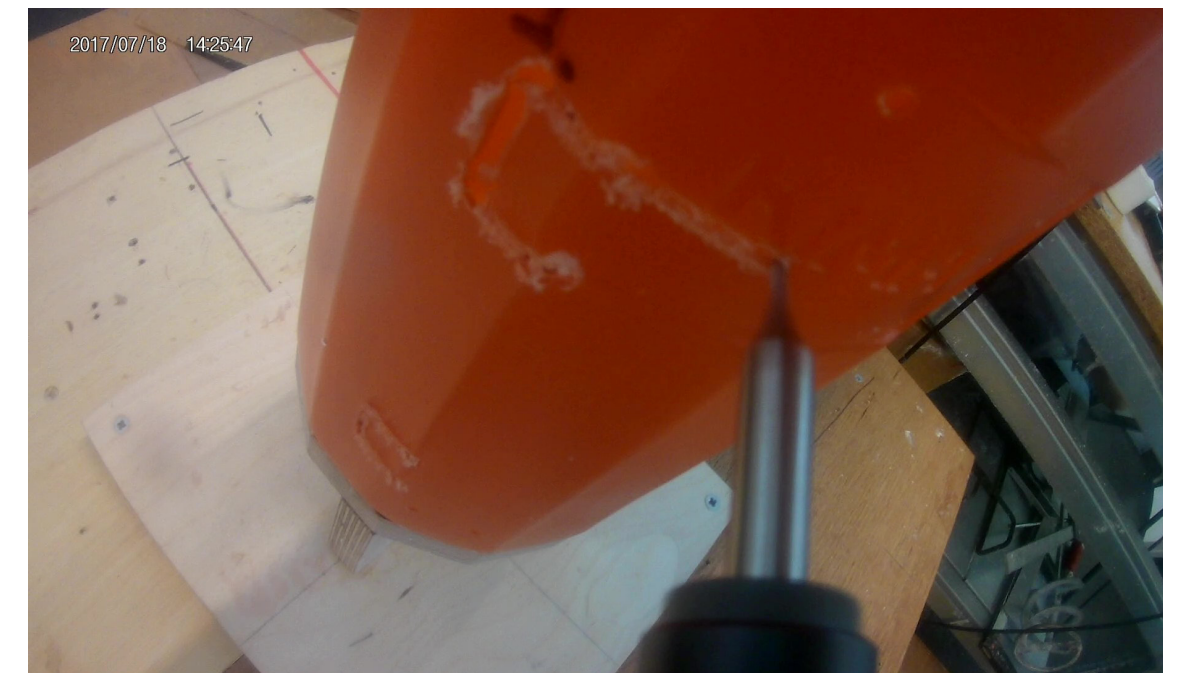
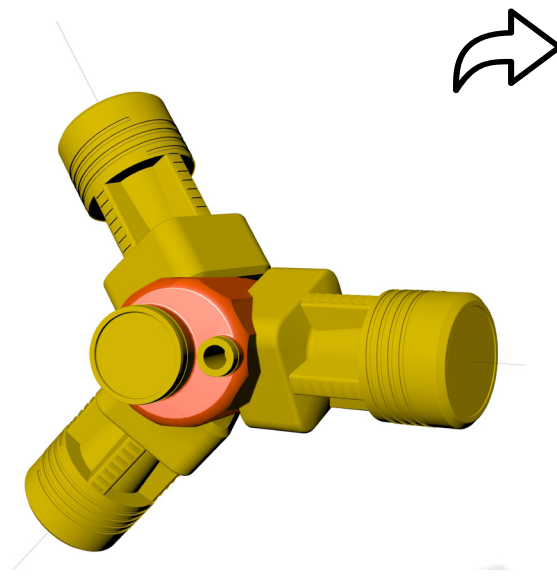

Figure 5.102: fourth test - STEP 2 | material removal





FINAL JOINT CONFIGURATION



STEP 1 : CUTTING LATERAL COMPONENTS

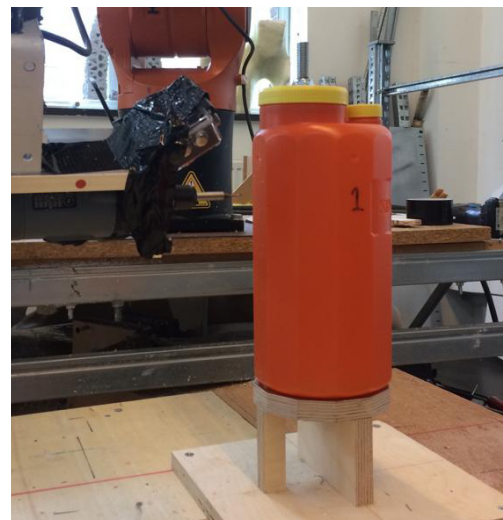

STEP 2 : CUTTING CENTRAL COMPONENT



STEP 3 : FOLDING LATERAL COMPONENTS



STEP 4 : GLUING THE WASHERS



STEP 5 : CONNECTING WITH RIVETS

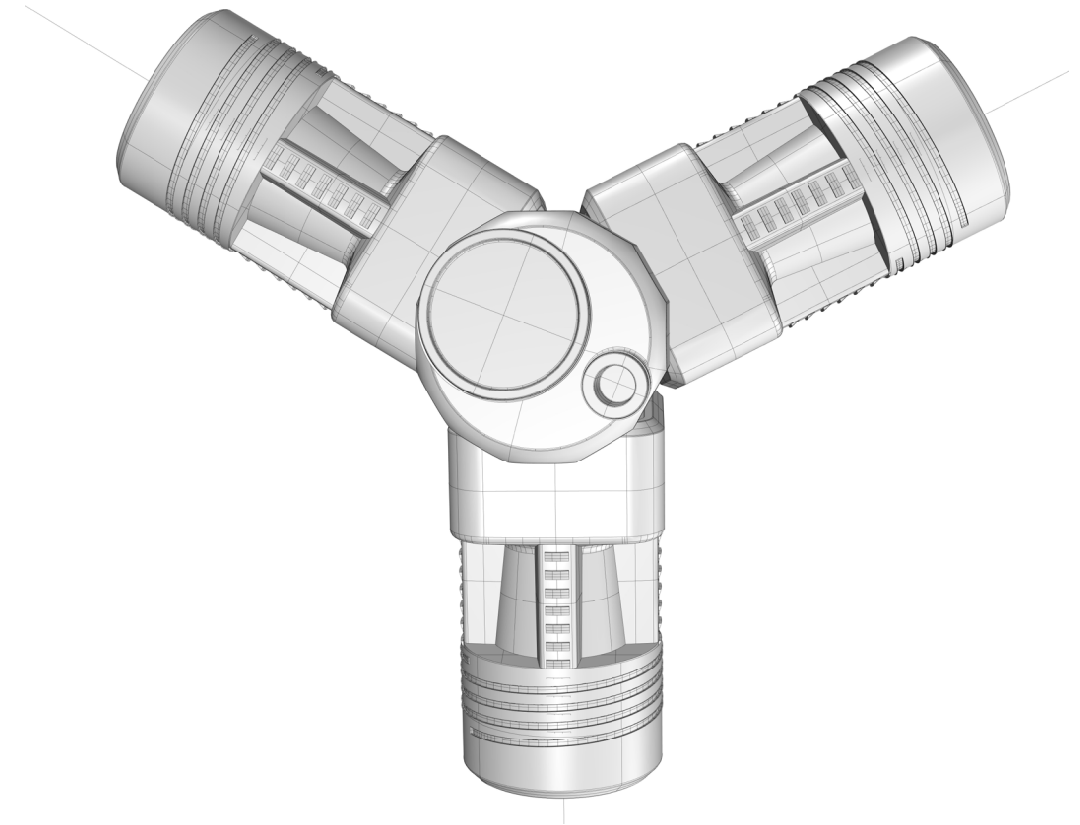

Figure 5.103: fourth test - Third Prototype I 3D model



Figure 5.104: fourth test - Third Prototype I Prototype



## Structural Test - Simulation

The third prototype was therefore analysed from a structural point of view in a finite element analysis tool called **ANSYS Workbench 19.1**, which is a software used to perform structural, thermal, and electromagnetic analyses.

For the purpose of the project one section of the joint configuration, namely the central component together with one lateral component, will be analysed in the Static Structural component of ANSYS. The aim of the simulation is to compare the behaviour of the geometry in the finite element software with the behaviour of the prototype when tested in the laboratory.

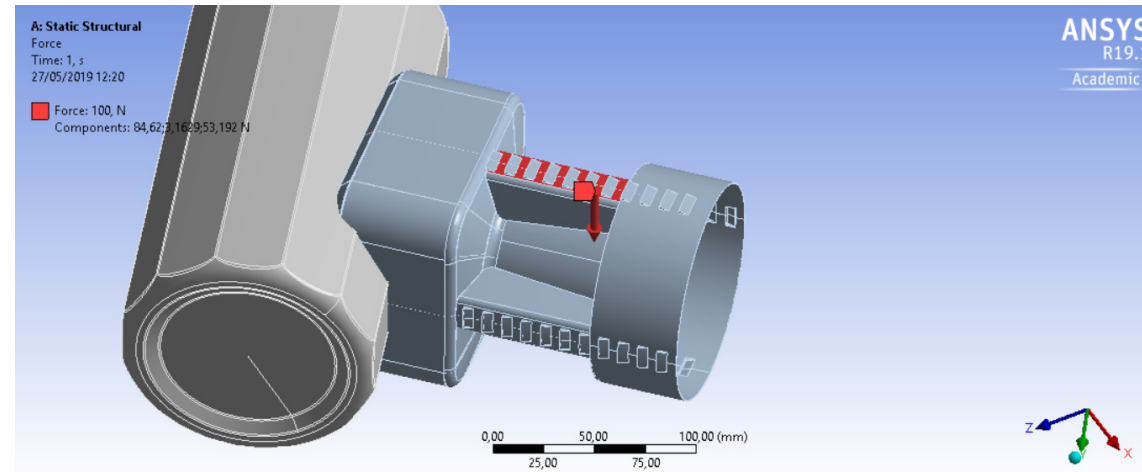

First, the 3D model of the geometry, previously made in Rhinoceros, is imported into Workbench 19.1, therefore the material properties are applied, in this case, Polythilene will be selected for both the components. Therefore, the connections between the components have to be defined and to conclude both of the geometry will be meshed. Finally, to perform the static structural analysis, the fixed supports and the loads have to be defined. In order to be able to perform an accurate comparison between the simulation and the structural test in the laboratory, the simulation has to approximate as much as possible, the configuration of the joint in the real environment during the structural test. Therefore, considering that the central element of the joint will be fixed at the ends and the load will be applied on the lateral component; in the static structural simulation in Workbench, the two ends of the central component will be selected as supports and a load of 100N is applied on the lateral component.

Concluding the simulation shows that under a load of 100N, the maximum deformation present in the joint is equal to 21mm, while the maximum equivalent stress is equal to 127 MPa.

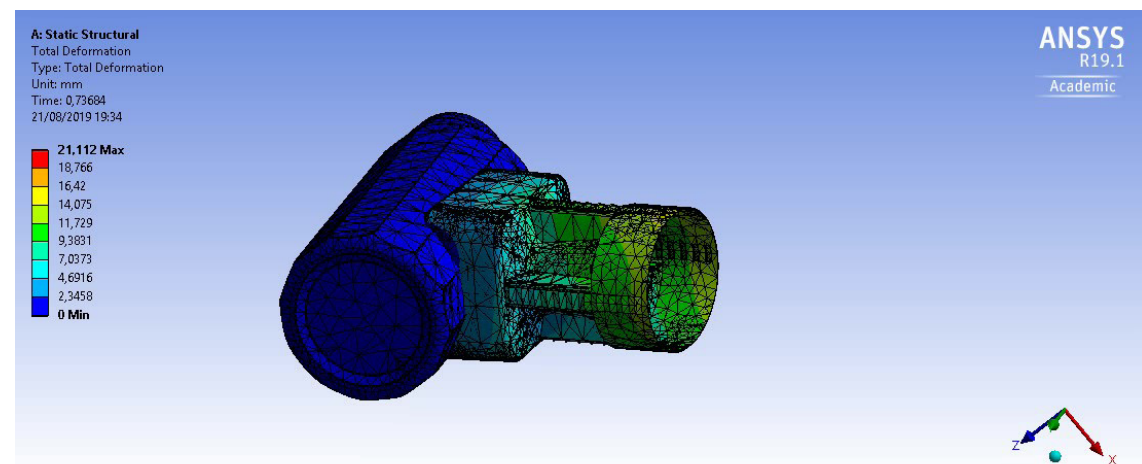

## Structural Tests - Real Environment

The second and the third prototype were then tested at the laboratory of the faculty of Mechanical, Maritime, and Materials Engineering (3ME) of the TU Delft, led by Dr. ir. F.A. Veer on the 28th of May 2019.

The first tested specimen, that is the third prototype, was subjected to the compression test using a Zwick z10 test bench and fixing in position the central component (orange), which is standing vertically on the steel base and is clamped at the top using a steel tube. At the same time, to measure the force required for the deflection, constant downward displacement of 10mm per minute is applied on the lateral component (yellow), making use of a wood block to apply the load, because of physical constraints.

The result obtained from the compressive testing are saved in an excel file that plots the necessary force to reach a particular level of deflection. The “useful range” in which we can determine the compressive stress of the tested joint is then determined.

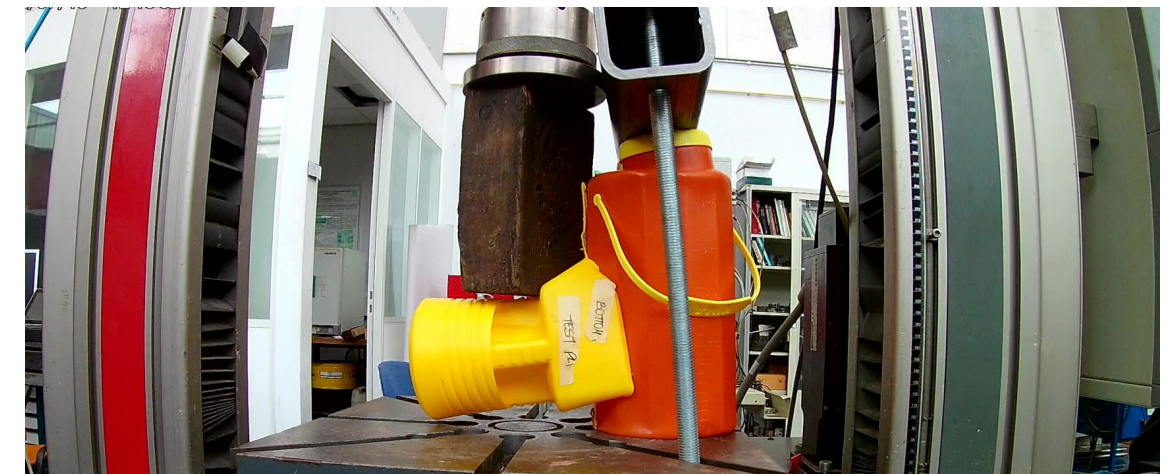

Figure 5.105: third prototype I test 1

The graph shows that the prototype was subjected to a maximum load of 40 Kg, which corresponds to a deflection of 40mm. The test then had to be stopped because the lateral component was almost touching the steel base of the test bench. Concluding, thanks to the ductile behaviour of the plastic, when the load is released, the joint is able to go back to the starting position without any substantial damage.

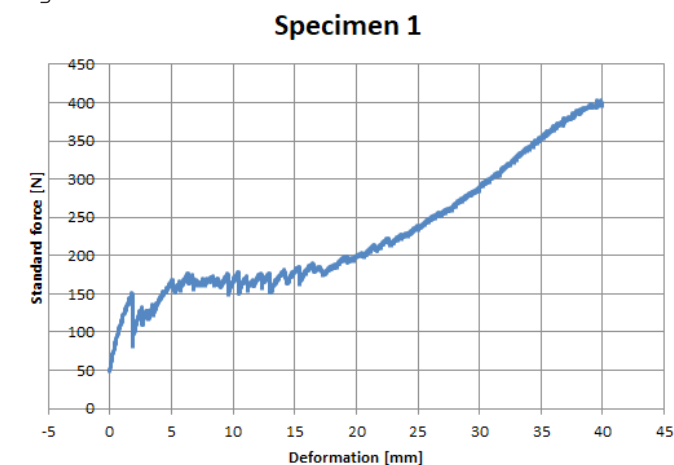

Figure 5.106: graph Force [N] / Deformation [mm] third prototype I test 1

The second tested specimen, which is the second prototype, was positioned horizontally on the steel base of the Zwick z10 test bench and a block of wood is placed on top of the joint, in between the prototype and the steel plate of the test bench. This specimen is also subjected to constant downward displacement of 10mm per minute and the results of the compressive test are saved once again in an excel file that plots the necessary force to reach a particular level of deflection.

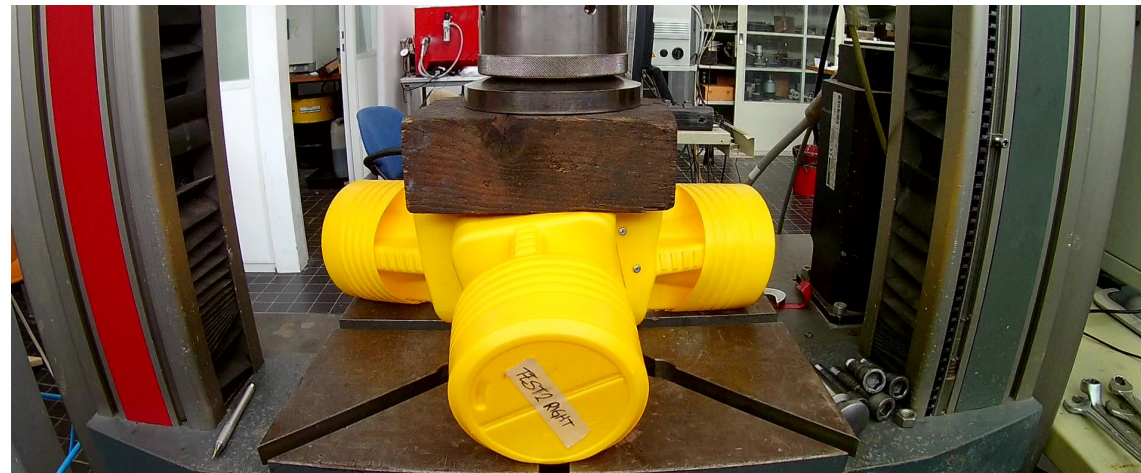

Figure 5.107: second prototype I test 2

It is possible to notice during the test that the section of material where the deformation is more visible is the base of the component; in fact, the joint results quite rigid, while the base is the weak point. Concluding, the graph shows a deflection of 40mm under a maximum load of 50 Kg. Moreover, also in this case, the joint is able to return to the original configuration without any substantial damage.

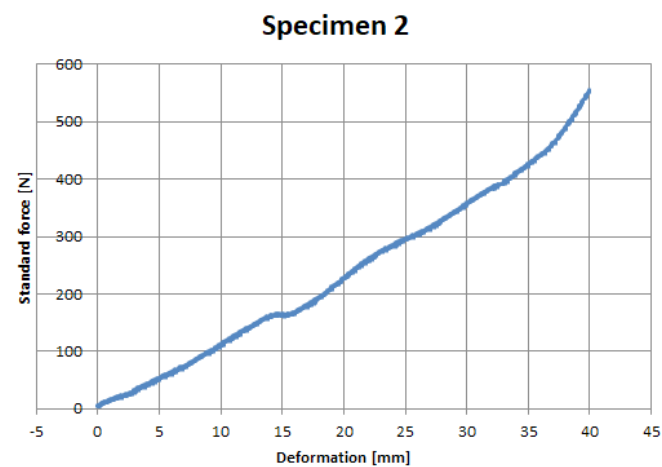

Figure 5.108: fgraph Force [N] / Deformation [mm] second prototype I test 2

## Membrane

The design for the panelization of the structure was based on the idea of not covering the structure of the pavilion, namely the PVC pipes and the joints, with the fabric. In fact, it is unlikely that the connection between the fabrics of two different faces would result watertight; therefore, the design of the fabric was based on the ideas of enclosing the membrane inside every hexagon, creating ornate shadows

Moreover, considering the complexity of the orientation of the faces, it was necessary to adopt a fabric that is stiff in both directions. Therefore different reused materials were selected and examined. Between the examined materials, the most suitable and interesting from an architectural point of view resulted the fabric used as truck protection, which is a heavy fabric and the semi-open membrane, used as outdoor sign. In conclusion, the semi-open membrane was selected because it is lighter compared to the truck protection fabric, and would allow the light to partially go through the pavilion.

Moreover it was particularly interesting the geometrical pattern and the writings that the membrane have on, in fact it is made of circles and different writings and every membrane from the same stock has a different pattern, even if following the same design principles. Therefore, it would create in the pavilion an interesting articulation of patterns. Furthermore, even if the membranes have different geometrical patterns and writings, they all have the same dimensions: 330x173 cm.

Concluding, the fabrication of the hexagons for the faces of the pavilion has to be custom made for every face but they all follow the same fabrication principles. First, the fabric has to be cut to size and then connected to the ribbon structure.

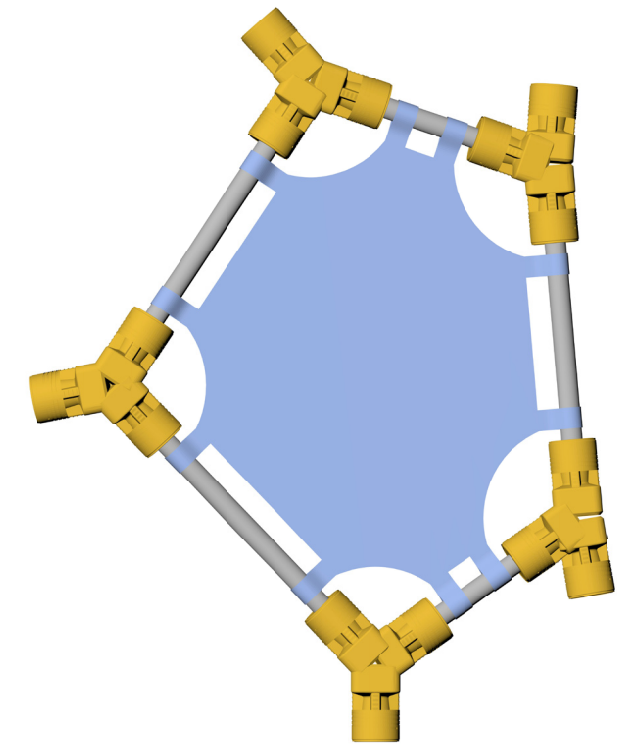

Figure 5.109: membrane design

The connection of the fabric to the pipes will have a similar concept to the one used previously in the connection of the components of the joint, in fact the material of the fabric itself will act as connection element to the ribbon structure (Figure 5.109). Therefore, it is important that the shape cut from the membrane will not resemble the face of the hexagons itself but it will integrate some stripes along the edges that can be folded around the pipes and connected to itself. Furthermore, the edges of the shape will have to be reinforced using double amount of material, which will avoid the tearing of the membrane caused by the tension present in the fabric.



## 5.6 3D Scanning

3D scanning is a process that allows collecting data that can be used to realize a digital 3D model through the analysis of the shape and the appearance of a real-world object or environment. However, different techniques can be applied to compute 3D coordinates, such as geodetic surveying or photogrammetry; therefore, it is difficult to find a generally accepted definition of which instrument can be considered a 3D scanner.

Nevertheless, from the point of view of the user, can be considered a 3D scanner every instrument that automatically collects 3D coordinate of a given region of an object surface at a high rate and in real time. There are different typologies of 3D scanners because they can be used in fixed positions, as a mobile system on tripods or similar or as airborne systems for topographic applications (Boehler, W., 2001). Moreover, 3D scanners have different applications in many fields, they are widely used in heritage recording as well as 3D photography, remote tourism, construction industry, design process, and others.

For the purpose of the research, at first it was employed an Autodesk software called **Recap Photo**. It is a desktop application, which utilizes Autodesk's upgraded Photo-to-3D cloud service to create a cloud-based solution tailored for UAV photo capturing processes and drone photo. Therefore, it is possible to create photo-textured meshes, photo-based point clouds with geolocation, and high-resolution orthographic views with elevation maps.

The workflow is basic; firstly, some photos of the object have to be taken for the reconstruction process. For the student, version is only possible to upload maximum of 100 pictures per project, while the minimum amount is the same as the subscriber's version that is 20 pictures per project. In principle, reconstruction is accurate within a  $\pm 1$  pixel of the input images. However depending on the accuracy and resolution of the camera, lens system, camera shake, plus other related variables, and on the number of the pictures; as a result, the resolution of the model will change. After the uploading of the photos, a 3D mesh model will be originated on the cloud and then it will be ready to be downloaded.

Below are shown the first attempts of 3D scanning of the drill container component (showed in the paragraph called Meso-Component scale) with the Recap Photo software according to different variables.

### First test

Number of photos: 22  
Camera: iPhone 5S, 8-megapixels, size of the pixels equal to 1.5 microns  
Background: neutral-white



### Second test

Number of photos: 20  
Camera: iPhone 5S, 8-megapixels, size of the pixel equal to 1.5 microns  
Background: neutral-white, image cropped to fit only the component



### Third test

Number of photos: 33  
Camera: iPhone 5S, 8-megapixels, size of the pixel equal to 1.5 microns  
Background: colorful base, top view images included



From these first attempts is clearly visible that, as already stated above, the higher the amount of the images, the better the resolution of the model. Moreover, is also possible to notice that the resolution of the model improves with a background that creates some contrast with the component.

In a second moment, it was considered to take into consideration the idea of **3D scanning with the robot**, using as a starting point the research carried out by the Robotic Building studio of TU Delft about the above-mentioned topic, research that considering the results obtained, resulted promising (Figure 5.98).

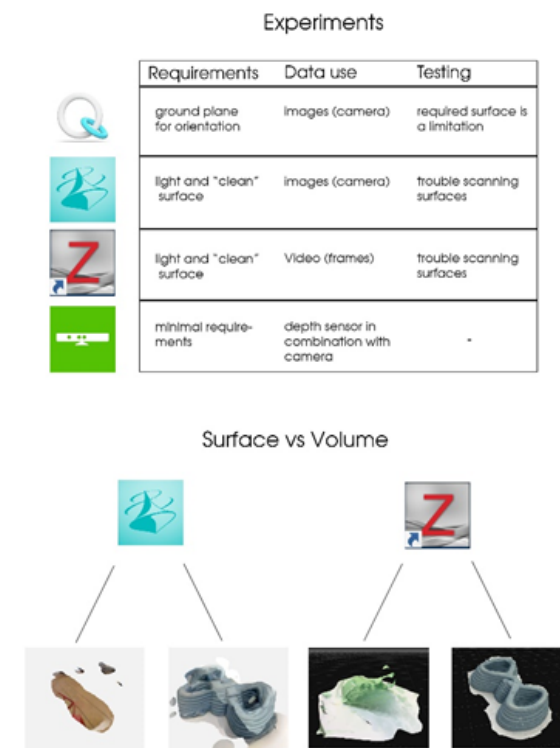

Figure 5.110: research regarding 3D scanning possibilities (Robotic Building, TU Delft, 2017)

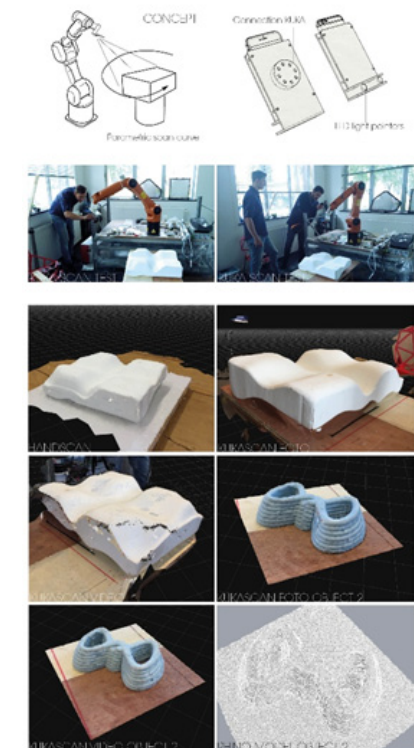

Figure 5.111: 3D scanning with the robot (Robotic Building, TU Delft, 2017)

However after the evaluation of the different possibilities, it was drawn the conclusion that 3D scanning is not the main focus of the research but it is necessary for its progression. In fact working with a precise and detailed model of the selected object is an important starting point for the robotic modification of the components, because it makes the process faster and more accurate. Therefore, it was decided to rely on a professional 3D scanner, precisely the Artec EVA 3D-scanner, available at the Royal Academy of Art of The Hague (KABK).



Figure 5.112: Artec EVA 3D-scanner

The **Artec EVA 3D-scanner**, it is a handheld 3D scanner used to rapidly obtain an accurate and textured 3D model of an object of medium dimensions.

It has a 3D resolution up to 0.5mm and a 3D point accuracy up to 0.1mm. It is easy to use, in fact it is based on the structured light process for which is only necessary to walk around the object with the scanner pointing at it for a couple of minutes and the scanner will create a 3D mesh of the object that is possible to modify and export in different formats.

Firstly it was scanned the lower part of the drill container component that being an intricate shape, it was scanned twice (Figure 5.113 and Figure 5.114), to be able to combine the two models at the end to get a higher resolution. After the base or body of the object, it was scanned the lid (Figure 5.115); the latter was scanned only once because it has a basic shape and it is less relevant for the research because the robotic modification concerns only the body of the component and not its lid.



Figure 5.113: Drill component - scan 1



Figure 5.114: Drill component - scan 2



Figure 5.115: Drill component - Lid

Consequently it was scanned the KIMA component, which even if less complex compared to the body of the drill container, was as well scanned twice to be able to obtain a detailed representation of both top and bottom of the component.

Besides, as it is possible to notice from the image below, for the KIMA component it was also imported into Rhinoceros the .mtl file containing the 3D scanned texture of the component, in order to achieve a more realistic representation of it.



Figure 5.116: Kima disposable laboratory ware - 3D scan

Afterwards the different scan were of every object were combined in order to acquire a precise 3D mesh model of every component, model that was then exported in the .obj format; which is compatible with the Rhinoceros 6 software.

Hence it was examined the 3D mesh and it was considered crucial to remodel the object in Rhinoceros 6 to be able to work with it. Indeed the 3D model obtained by the scanner was based on millions of polygon meshes (Figure 5.117), that compared to surfaces and polysurfaces make the object much heavier for the computer to process it, and they are more complicated to work with.

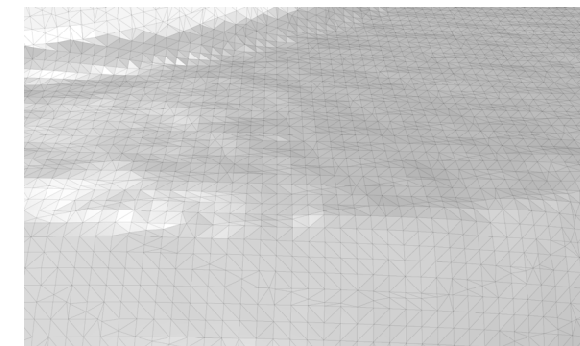

Figure 5.117: 3D scanner model - polygon meshes

Concluding, based on the 3D scanner mesh models it was possible to realize an exact model of the objects used in the robotic modification process, making the 3D scanning a substantial step for the success of the research project.



REAL OBJECT



3D SCANNER

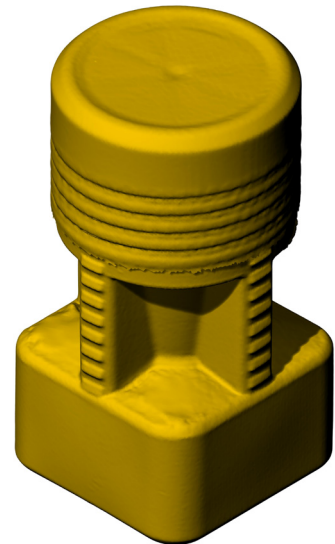

3D MODEL

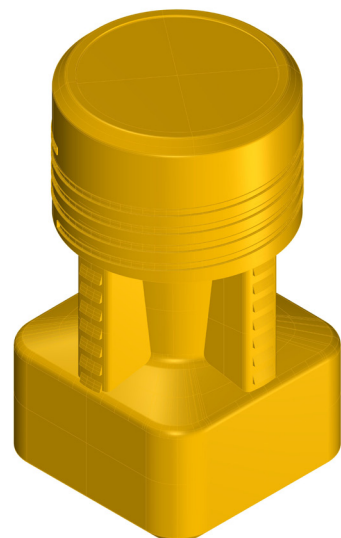
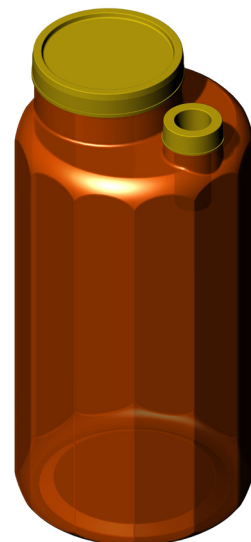

## 5.7 Robotic assembly automation

The purpose of this chapter is to suggest some guidelines in order to further implement the assembly of the joints developed during the research projects and reduce the required manual input. In fact, the connections represent the most complex part of the design; therefore, they are the part that would be more beneficial to robotically automate.

Throughout the course of the research, the design and fabrication of the joints have been improved from different points of view. Indeed the robotic tool path was integrated into only one path for the milling and one for the drilling of the holes, which made the process faster and more efficient. However, the folding of the material of the component itself, in order to use it as connection element, it is still human operated and the same applies for the connection of the components to each other.

Therefore, the actual configuration of the joint assembly consists in a fix robot, a moving tool (drill) and a fixed object, which is the component positioned in front of the robot. Consequently, the folding and the assembly of the joints is realized outside the robotic setup.

Accordingly, with the aim of reaching a level of automated prefabrication for the joints of the structure, a multi-robot setup is proposed. In particular, the new configuration will integrate the all assembly process into the robotic fabrication setup, introducing first a cooperative robotic assembly, including a human operator, which will control the collaborations between the robots. Furthermore, the fabrication sequence of the joints will include two fixed tool: a milling tool and a heat gun, and two moving tool: a gripper and a bolting tool. Concluding in the new configuration the component will not be fixed in front of the robot but it will be moving with it.

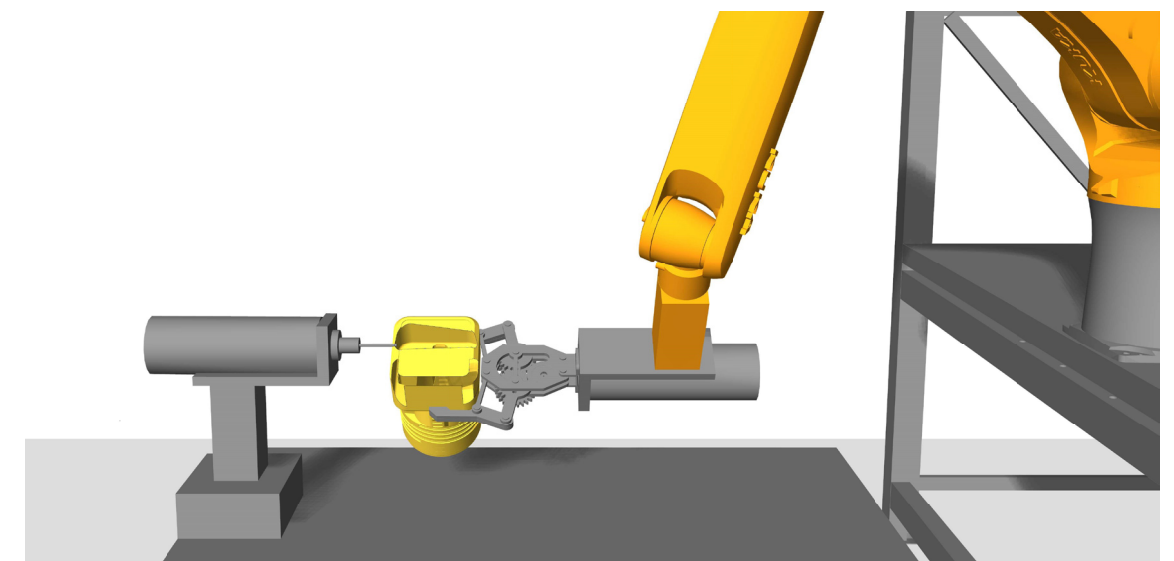

Figure 5.118: milling of the component with the Master robot

Thus, the first step of the fabrication sequence will consist in the picking of the first component from the reference point using the Master robot, which is equipped with a gripper, moving then the object around the milling tool and performing the necessary material removal (Figure 5.118). After that, the object is positioned in front of the heat gun, in order to heat the folding line of the component for one or two minutes, time enough for the plastic to become malleable and for the second robot to come in and easily fold the material using a gripper (Figure 5.119 and Figure 5.120). The above-mentioned sequence between the two robots is repeated for all the parts of material that need to be folded in order to perform the final assembly.

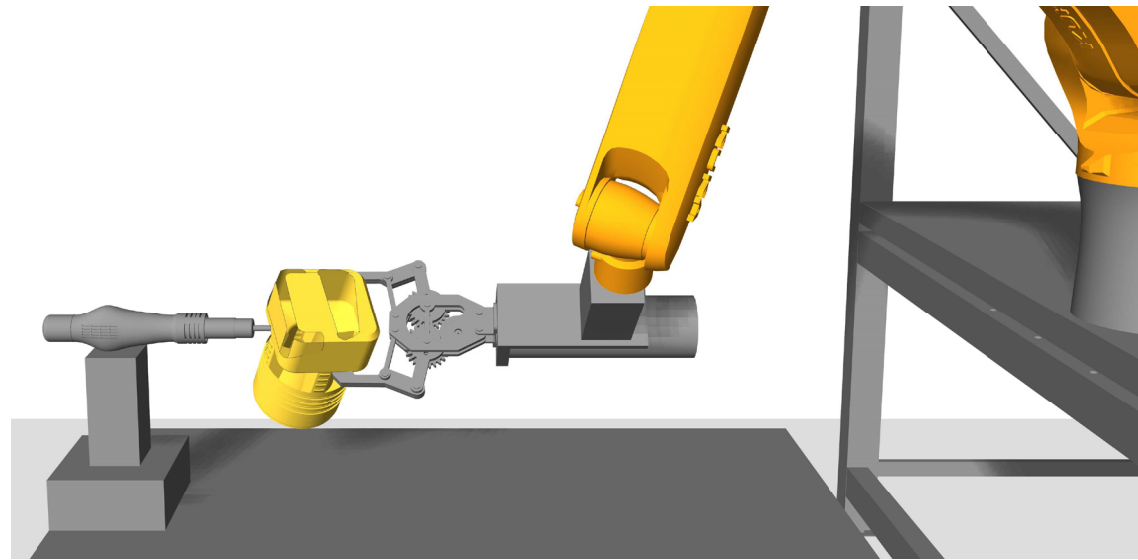

Figure 5.119: heating the folding line with the Master robot

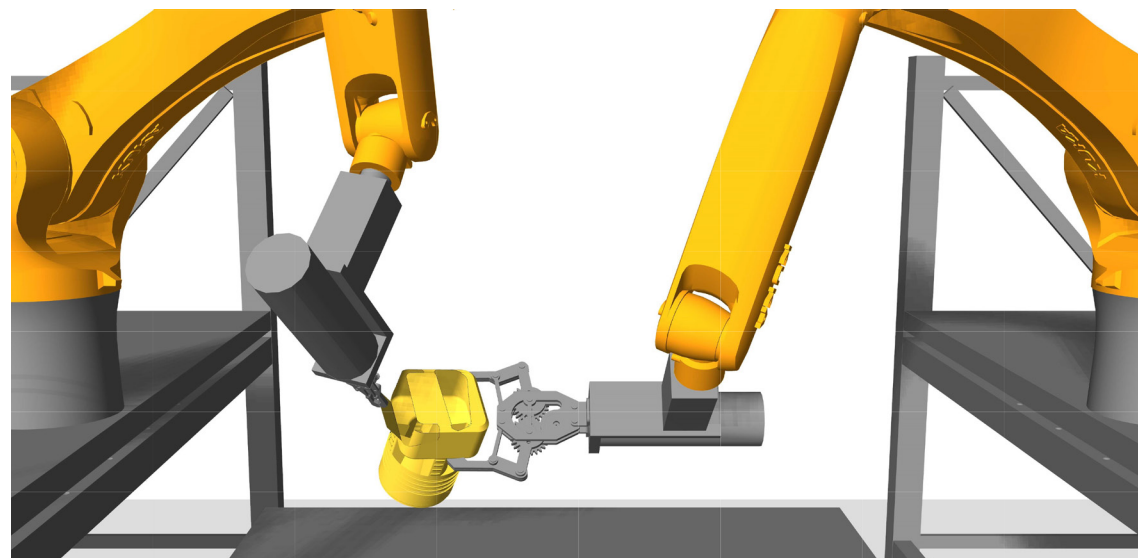

Figure 5.120: multi-robot setup - folding the material

Thus, the master robot will position the already folded object in a mould, which represents the assembly site. Indeed, after that all of the above mentioned steps are repeated also for a second component, the last step of the fabrication sequence regards the connection of the objects to each other. The connection will be performed by the second robot, which is equipped with a bolting tool, in collaboration with the Master robot, which will hold the component in place (Figure 5.121).

Accordingly, the fabrication sequence will be performed also for the third and last component of the joint, with the aim of transforming the assembly process of the joints into a fabrication-aware design of robotically assembled connections, in which two cooperating robotic arms alternate their function along the fabrication process.

Concluding, is important to notice that the described robotic fabrication setup is intended as topic of further investigation and possible extension to the research, in order to automate the gain further insight on how the automation of the robotic assembly sequence could influence the design of the connections.

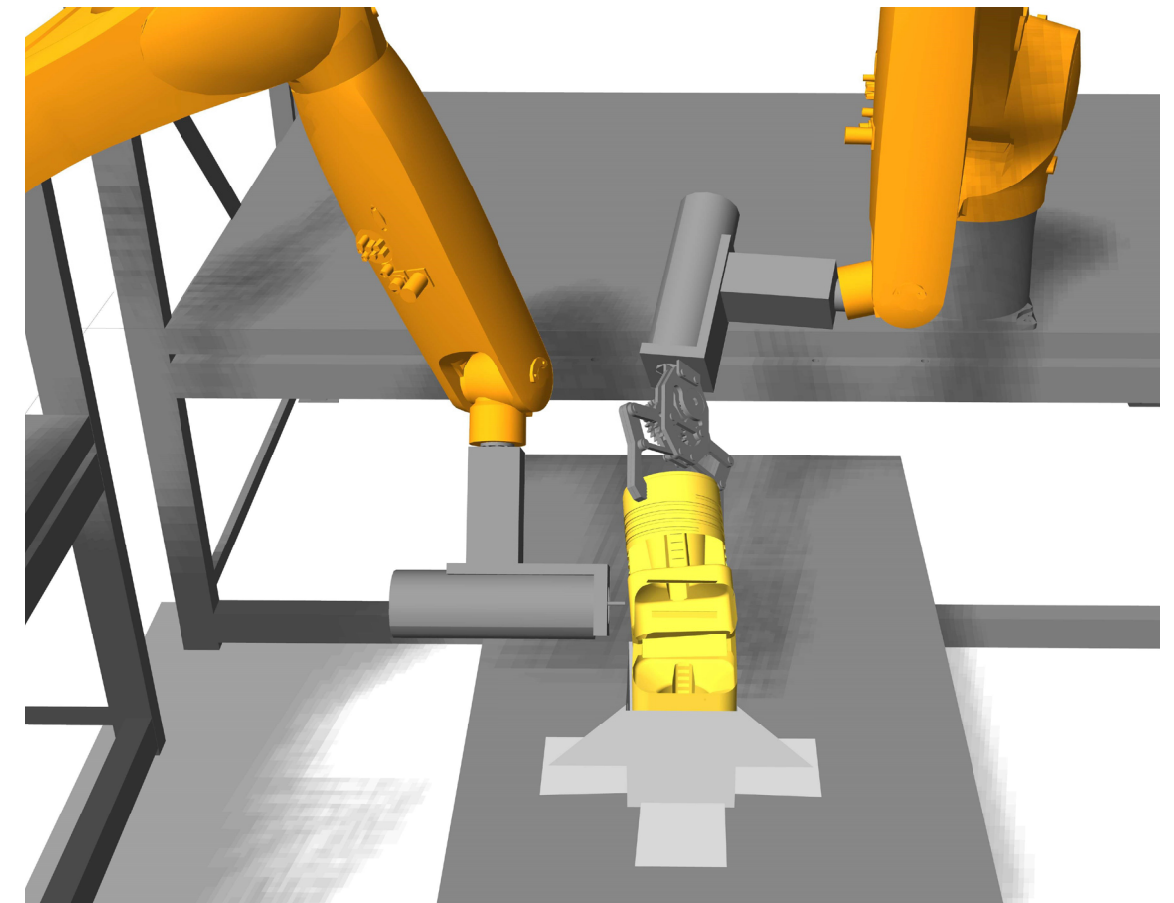

Figure 5.121: multi-robot setup - connection of the components



## 5.8 Final design

### Pavilions

In their essay *The Castle and the Pavilion*, Peter and Alison Smithson polarised architecture into two broad categories, castles – heavy, enduring and programmatically detailed, and pavilions – light, temporal and programmatically vague and trivial ( Self, M., et al. 2011).

In fact, the idea of building a pavilion would allow the designer to focus more on the material and building itself, rather than on the programme constraints. Therefore, pavilions projects often act as prototypes for ideas that can be further developed in buildings. Moreover, thanks to their temporary function they allow different concept and solutions to be evaluated, allowing more freedom in the design, properties which make pavilion structures, the most suitable for the application on the macro scale of the research project.

### Conceptual Design

The starting point of the design was the selection of the site for the pavilion in order to inform the design with the specific of the site. The chosen location is the Free Zone area, close to the TU Delft Auditorium, which, as already stated above, is a public outdoor space often used for events in the TU Delft campus.

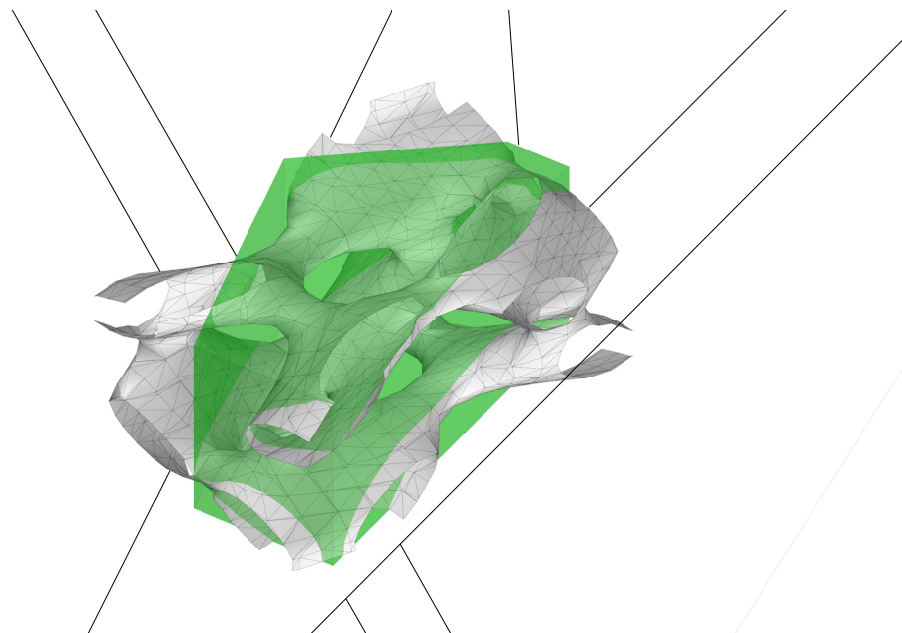

Figure 5.122: Grasshopper - Bounding Box for minimal surface

Consequently, a bounding box was set up, defining the exact dimensions of the interested area (Figure 5.122). The main concept of the design was to develop and incorporate project specific computational tools, which allows more rigorous explorations in early design phases.

Diverse design languages were experimented in this matter, but one of the most meaningful resulted to be the one regarding surface-based cellular structures. Actually, engineers have been studying the topology of surface based cellular structures for a century, in fact, these typologies of surfaces are particularly interesting because when subjected to some constraints, the total surface area is minimized. These kind of geometries are commonly defined minimal surfaces, or minimal periodic surfaces, because they repeat their structure in three dimensions.

Moreover they offer a significant departure from traditionalist concepts of structure because they are characterized by a high level of formal efficiency that sets into motion a variety of organisational connections (Van Berkel,B; 2016).

Consequently, in order to be able to apply the principles of the computation design, the minimal surface mesh needs to be panelized, in order to create a cell-like 3D spatial division from which is possible to extract the wireframe structure.

However, before panelizing the mesh is important to find the right density of the mesh, in fact considering the dimensions of the joints, the edge length of every cell can't be smaller than 360mm (Figure 5.123 ).

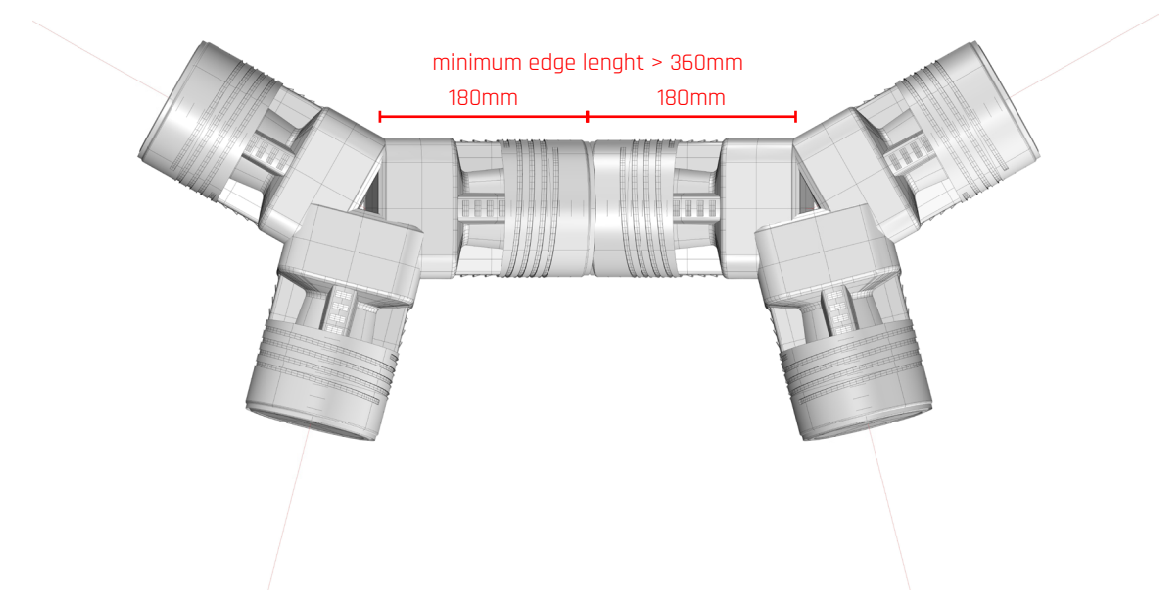

Figure 5.123: minimum edge length

By varying the density of the mesh is therefore possible to achieve different variations on the spatial division of the geometry. These different variations are experimented through the Mesh Machine tool from the Kangaroo physics plugin. This tool has a list of parameter which will give to user more control over the refinement of the mesh. The first tool 'Fix curves' allows the user to keep some curves sharp during remeshing, in this case the naked boundary component is used to extract the boundary of the mesh in order to fix the mesh at the boundary. Another tool is the 'Length', which allows to indicate a number that will define the length of the mesh edges. At the end, the Boolean toggle is used to run the algorithm and it has to be reset to true and again to false every time that the edge length is changed. Concluding the Dual Graph component from the Weaverbird plugin, is used to produce a hexagonal pattern on the mesh, connecting the center of the edges to the center of the mesh faces (Figure 5.124).

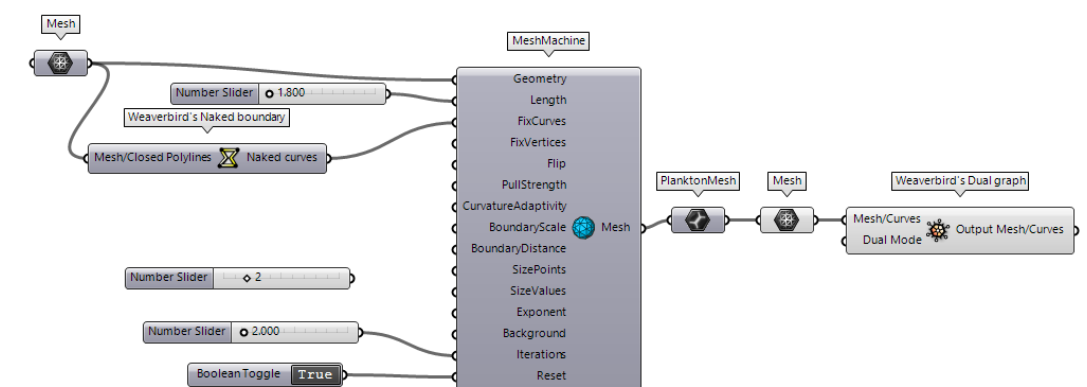

Figure 5.124: Kangaroo physics - Mesh Machine tool

The above-mentioned process was repeated several times to achieve the right density of hexagons and to be able to apply the joints to the shape avoiding the creation of pipes with a length smaller than 360mm. The process was first applied to the Split P minimal surface (Figure 5.125) and in a second moment to the Scherk surface (Figure 5.126).

The Split P surface consists of a double frequency P surface whose graph consists of 8 or 6 valent nodes each in the center of its respective octant of the unit cube. As those coefficients become nonzero, each of the nodes splits into two tetravalent nodes, which move apart along the lines passing through the octant centers occupying the unit cell (Weisstein, E., 2002). On the other hand, the Scherk surface consists of two complete embedded minimal surfaces, of which the first one is a doubly periodic surface and the second is singly periodic. The two surfaces are associate family of each other.

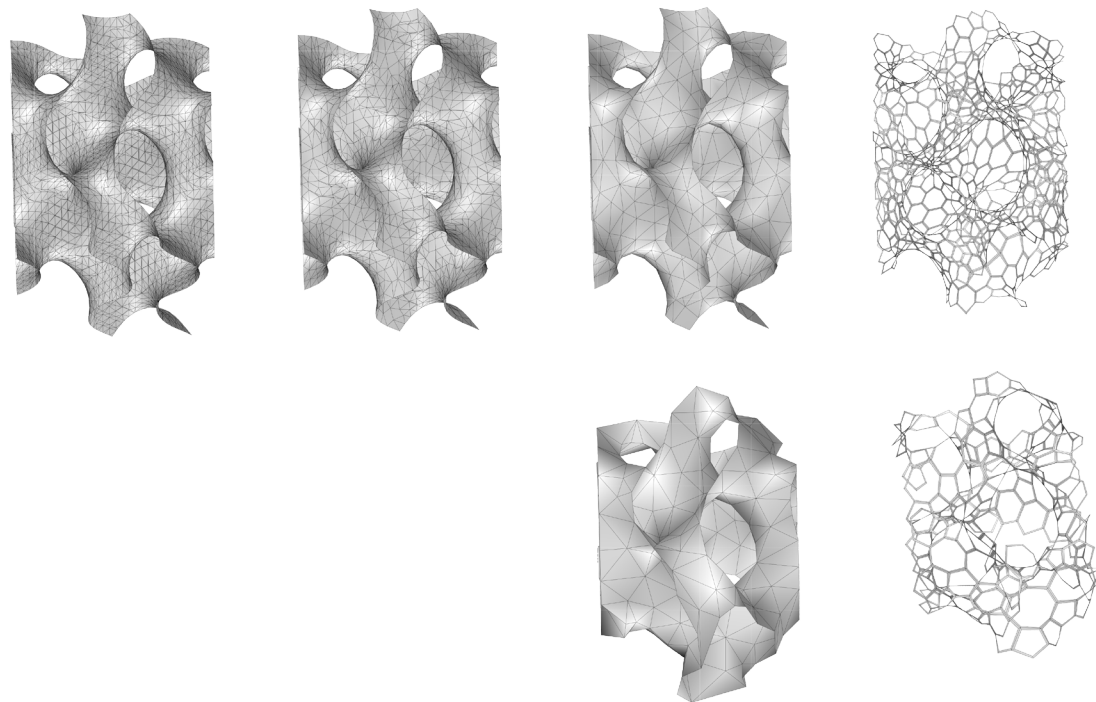

Figure 5.125: Mesh Machine - Split P surface

Moreover, from an architectural point of view, the first shape was particularly interesting because the complicated shape corresponds to the structure itself, finding strength in the form itself. It is particularly interesting to observe how the network of surfaces turn in, on and around themselves, deceiving any predetermined concept of entrance, exit and enclosure. At the same time being able to act as a self-standing structure, which twist in multiple ways.

On the other hand, the second shape results promising because it engages more with its surroundings, it indeed creates some passages that could follow the pattern of the existing road structure but at the same time preserving an intricate complexity of form.

However, both of the above-mentioned shapes resulted, under a deeper examination, too complex to act as proof of concept of the system developed during the research project. In fact, first of all reducing the complexity and remeshing the shapes multiple times was necessary in order to be able to make the shapes applicable to the computational system, therefore the simplification led to a loss of complexity and at the same time aesthetic value of the shapes. Moreover, it was also evaluated that both of the developed geometries were not enough involved with their surroundings, in fact in the first case the geometry does not relate at all with the context, and in the second one, the shape does not valorise enough the context where it is situated.

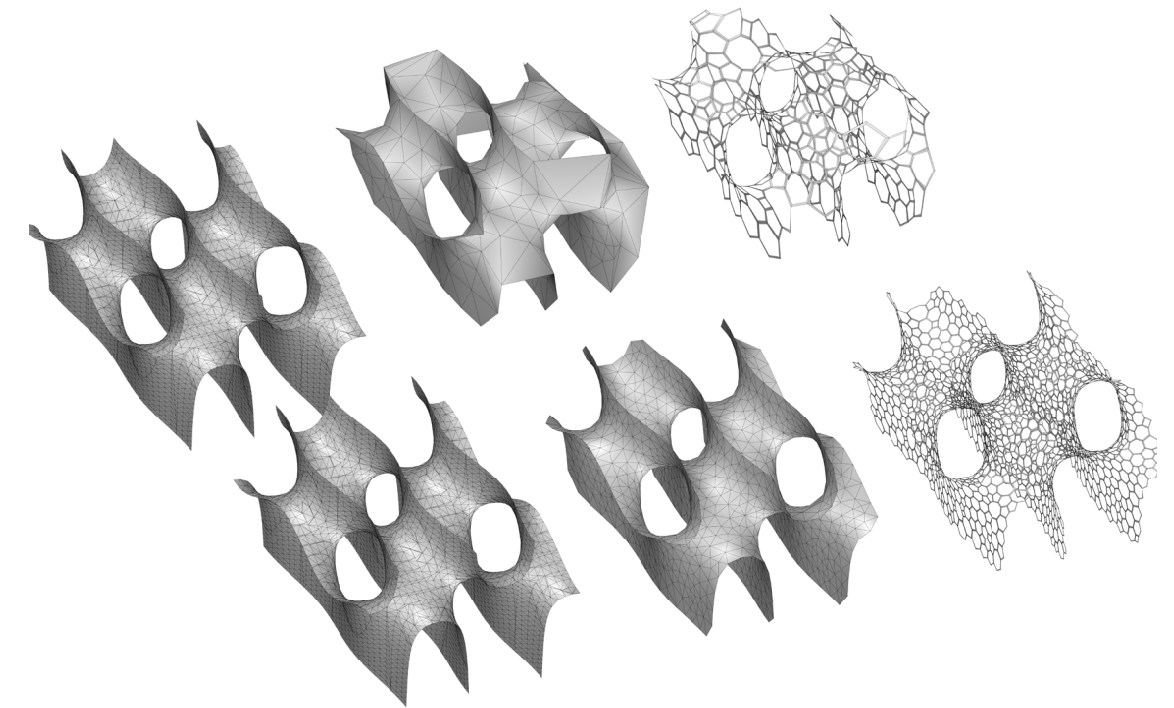

Figure 5.126: Mesh Machine - Scherk surface

Hence, with the aim of developing a structure that has a stronger relation with its surroundings, the amphitheatre project from the architecture firm called theverymany, was taken as starting point for the development of a new design approach (<https://theverymany.com/public-art/argeles-sur-mer>).

In fact, as they firm does in the above mentioned project called pleated inflation, a 2D network of lines as a footprint where developed based on the intersecting roads of the location (Figure 5.127).

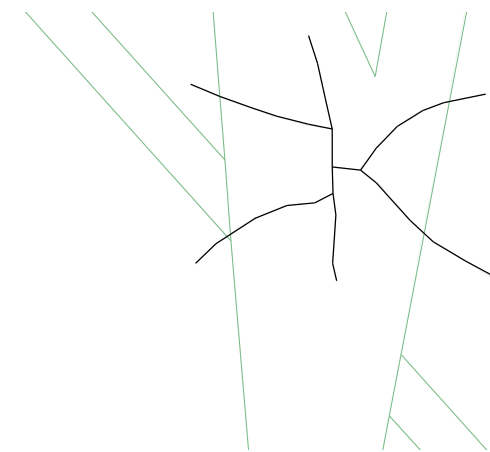

Figure 5.127: 2D network of lines

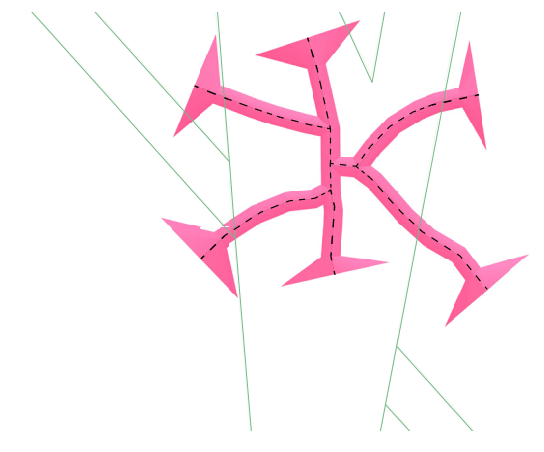

Figure 5.128: 2D network of lines - basic shape

Therefore, thanks to a computational system based on some Force objects and Anchor points connected to the Kangaroo Physics Engine, the 2D network of curves inflates and expands in the air. In particular as Force inputs in the script are used:

- Pressure: area dependent pressure acting on every triangle of the mesh, inflating the geometry
- Springs from lines: both in U and V direction
- Unary Force: vector force acting on multiple points and simulating the effect of Gravity.



The result is a shape that works at the same time as structure, enclosure and spatial experience. In fact, the pavilion consists in a vaulted structure, which meets the ground on six plates and with double-curvature to increase the structural performances and become a self-supported shelf. Once inflated, the designed mesh is improved thanks to the already mentioned above Mesh Machine component and after that is tessellated with the Dual Graph component.

Concluding, the computation system developed during the research project is applied to the tessellated shape; namely first are positioned the joints based on the drill container components, secondly the PVC pipes are placed in between the joints and connected to them, at last the membrane is placed, covering every facet of the shape and connected to the PVC pipes. The result is a pavilion that serves as event space and thanks to the distance between the membrane and the PVC pipes casts in the ground ornate shadows.

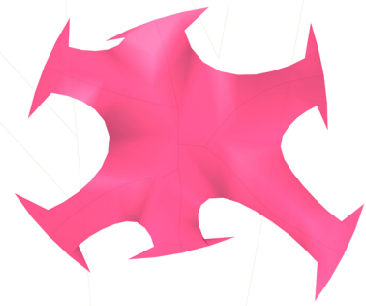

Figure 5.129: inflated geometry - top view

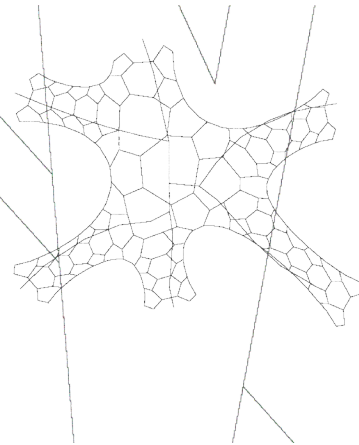

Figure 5.130: tessellated geometry - top view

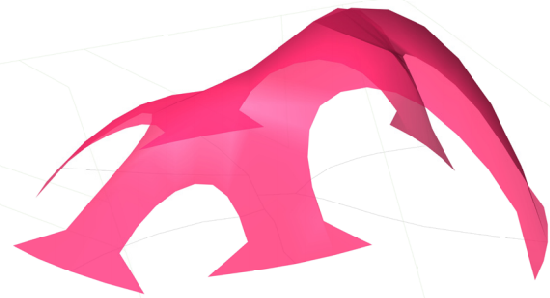

Figure 5.131: inflated geometry - perspective view

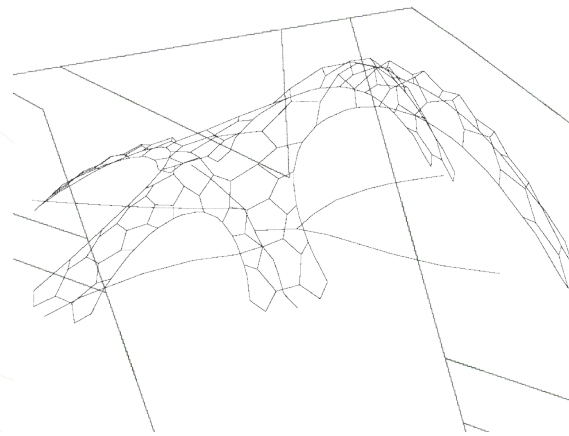
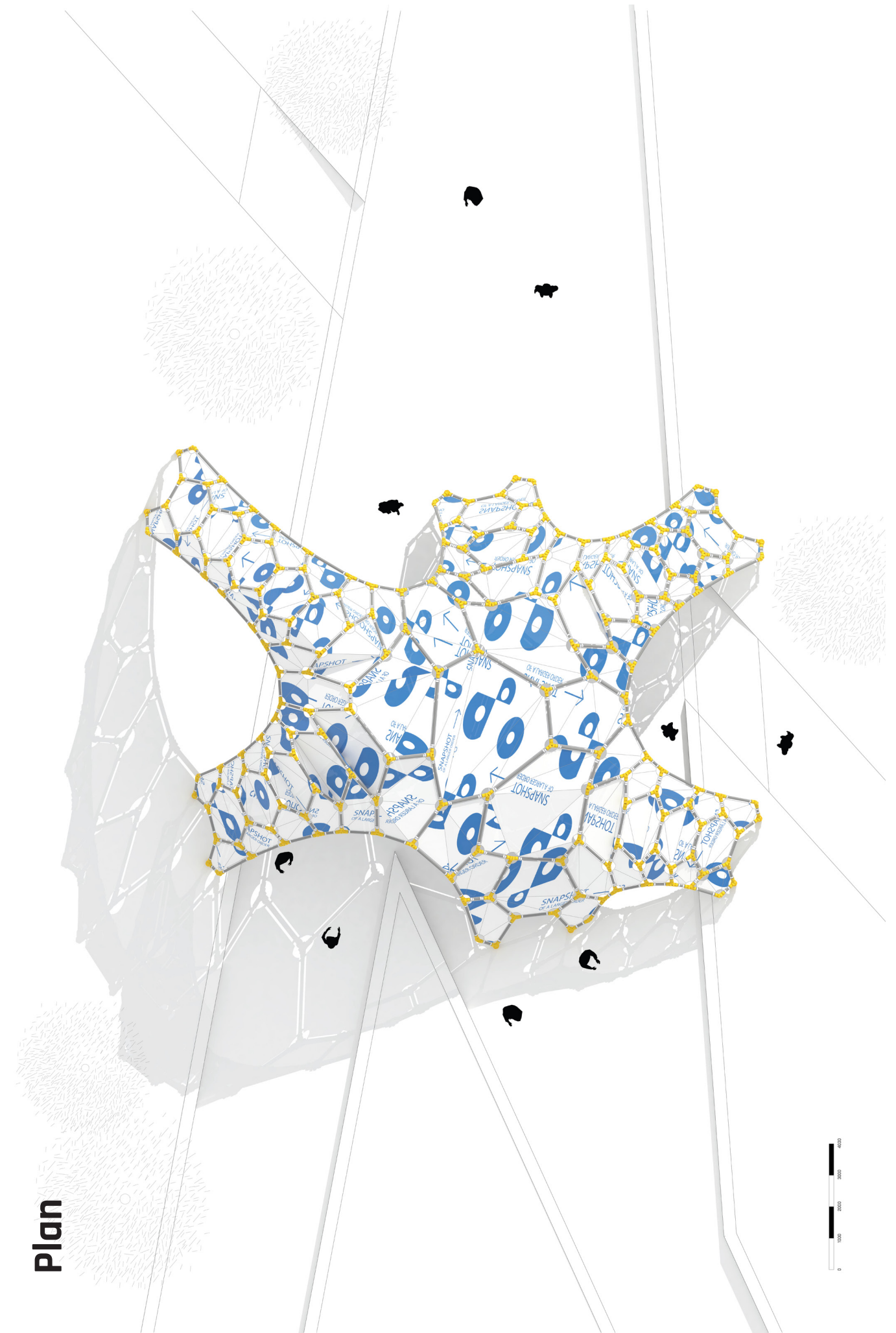

Figure 5.132: tessellated geometry - perspective view



Plan



# East Elevation

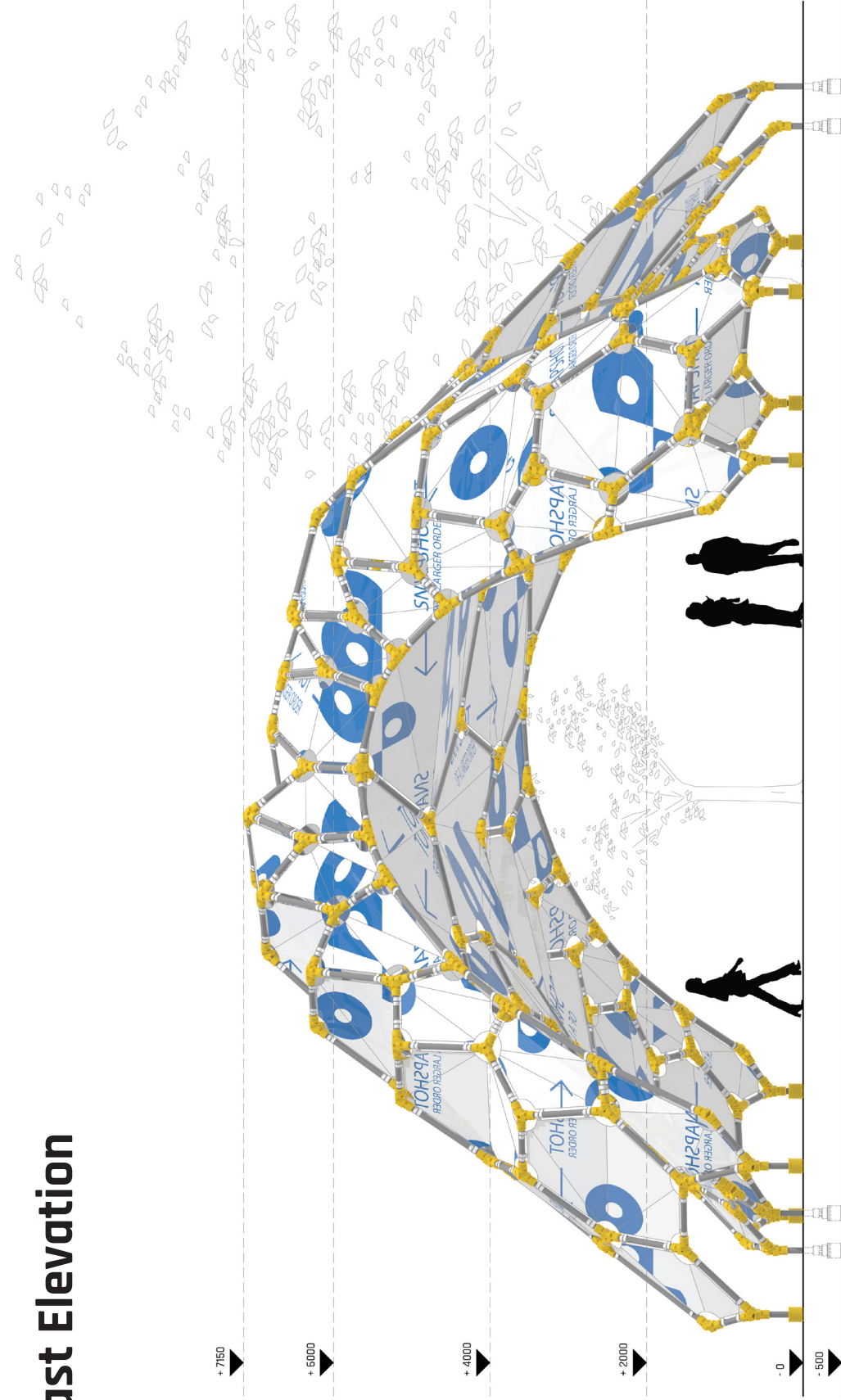

# North Elevation

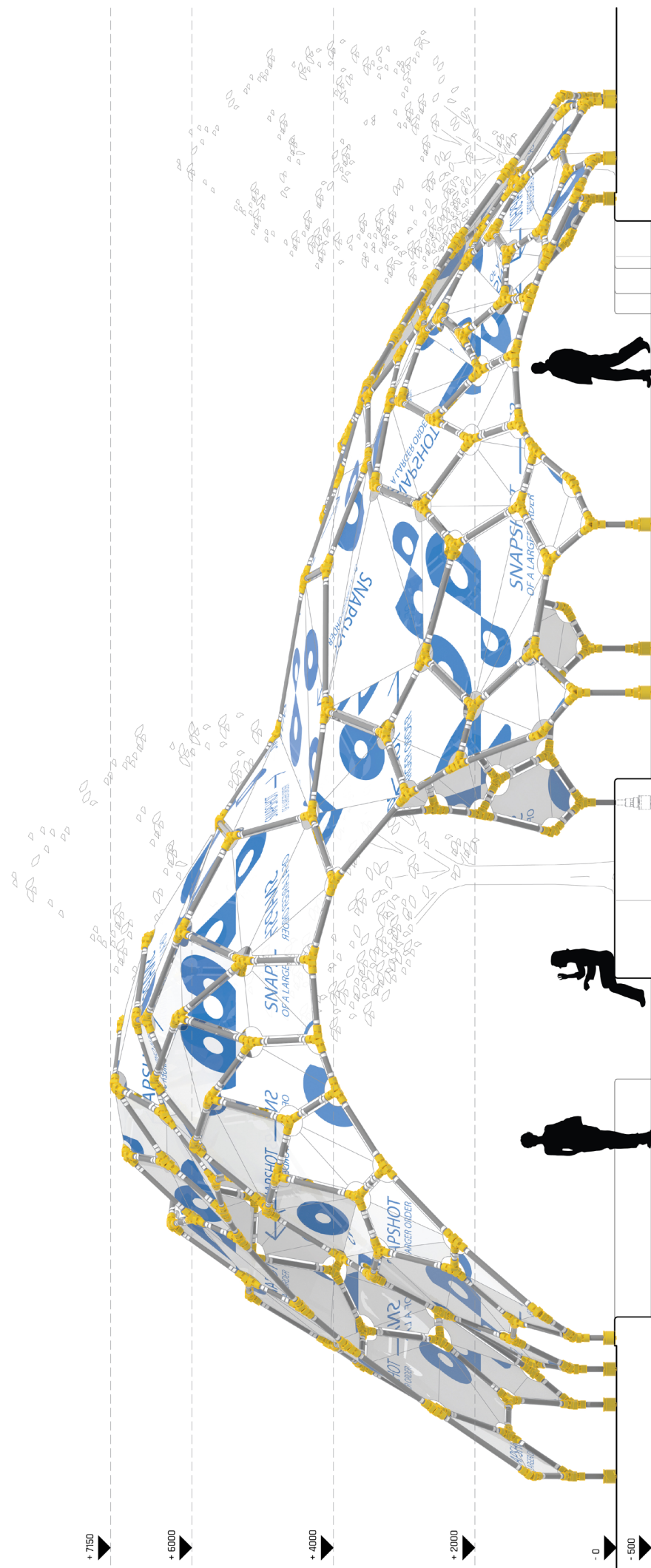



# South Elevation

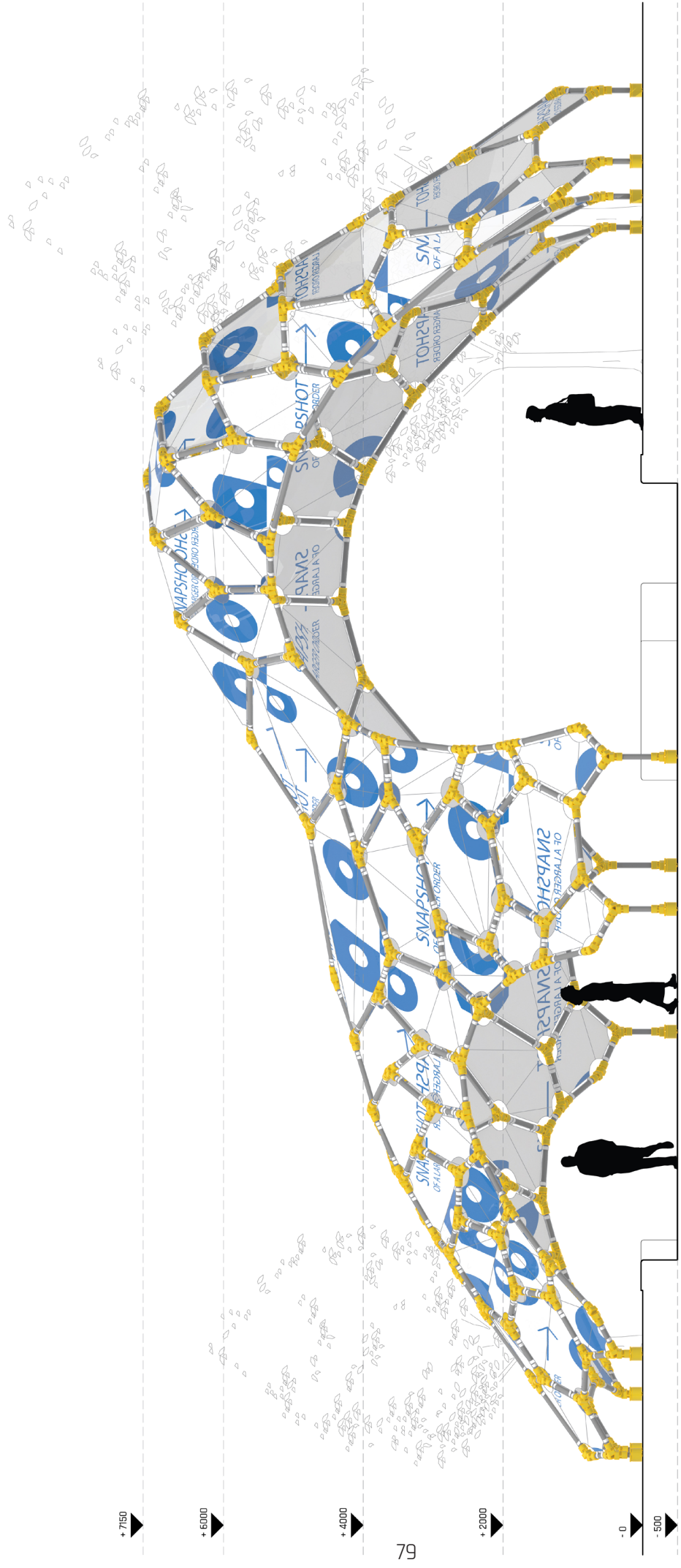

# West Elevation

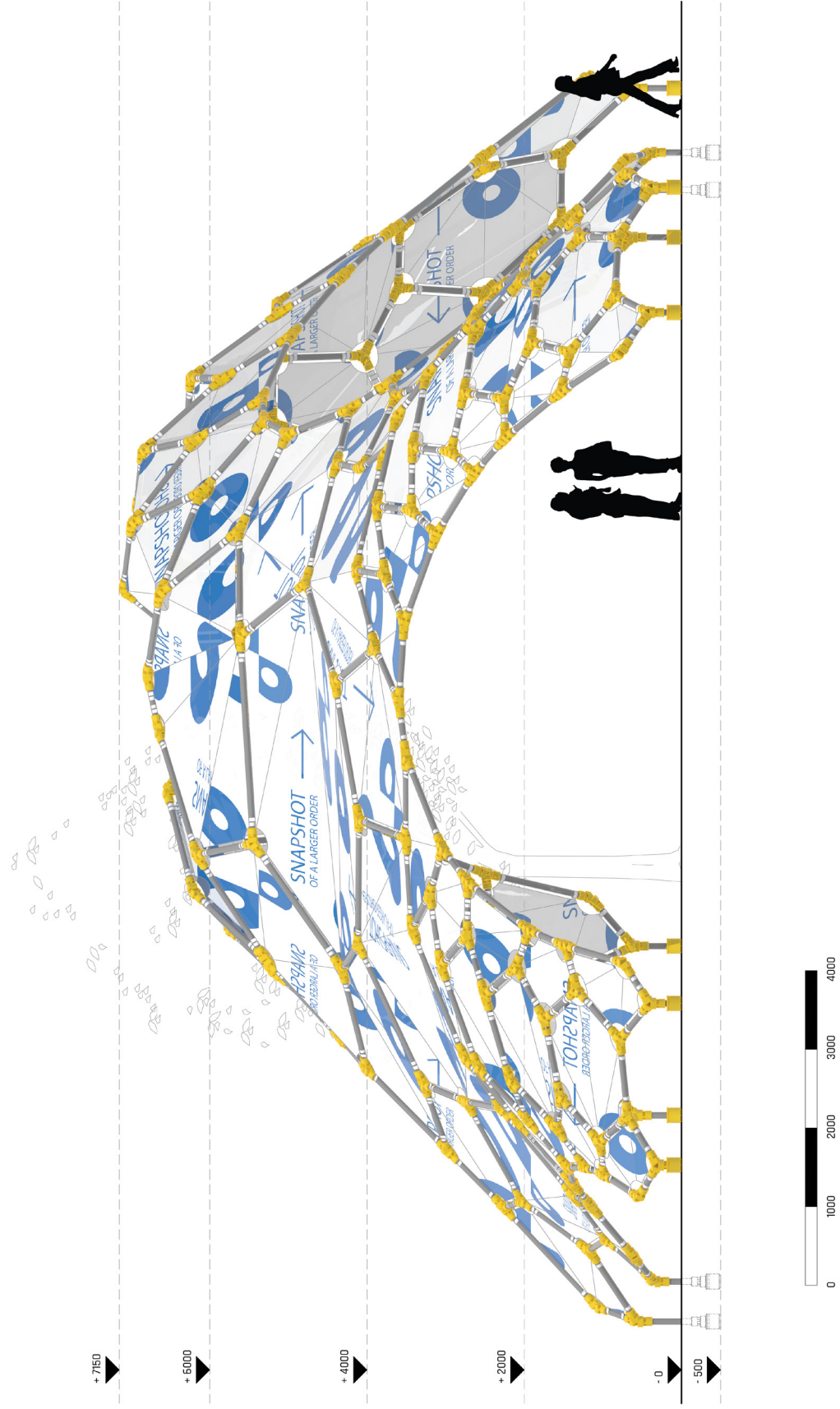



# Section A-A1

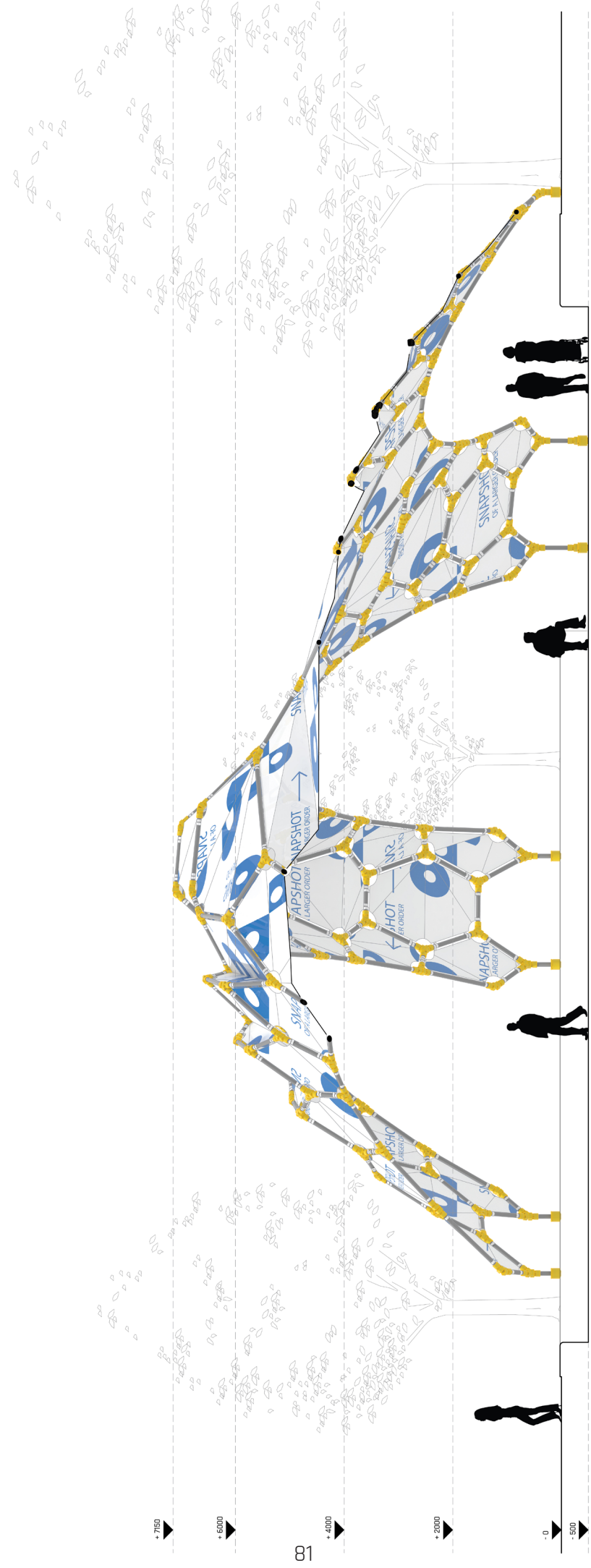

81

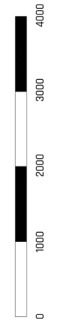

82





Figure 5.133: Perspective view of the west side of the pavilion in the location



Figure 5.134: Perspective view of the south side of the pavilion in the location



## Structural Analysis

To further assess the structural performances of the geometry, it was analysed in the Grasshopper plugin Karamba 3D. The latter, being embedded in the parametric design environment of Grasshopper gives the possibility to combine parametric 3D models with finite element calculations. The process is equal to the one explained in the Chapter 5.3, in fact the shape is approximated to a wireframe structure subjected only to gravity load.

First, the structure behaviour is analysed setting PE as material property, material of the joints and already used in the Chapter 5.3 for the simulations. In a second moment, the geometry is also analysed selecting as material property PVC, which is the material of the ribbon structure that consists of PVC pipes.

The wireframe structure is analysed as a set of beam elements, which meet at common points creating rigid connections. Moreover, the twelve nodes pinned as supports of the structure, are modelled as fixed wall supports, restraining translation along x,y, and z-axis.

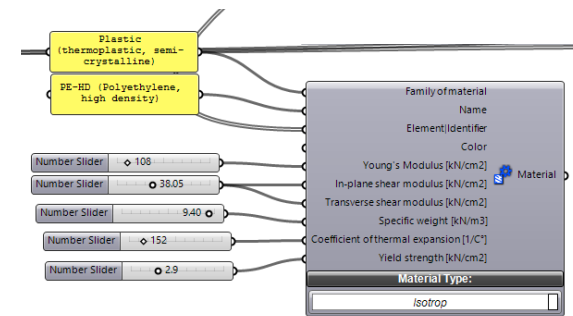

Figure 5.135: Karamba - mechanical properties PE

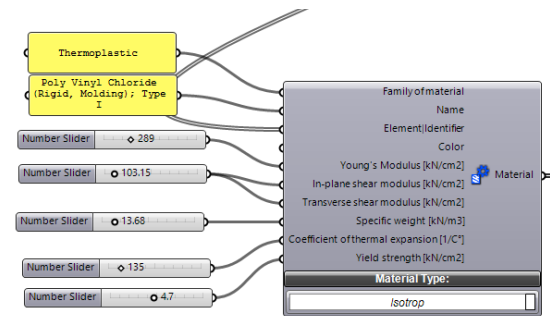

Figure 5.136: Karamba - mechanical properties PVC

Consequently, the **mechanical properties of the materials** used for the beams needs to be defined. The properties used as input for the analysis are derived from CES Edupack 2018 (Appendix B). As already stated above, the calculation is run first using as input the material properties of PE-HD (Polyethylene, high density) and after that using the ones of PVC (Poly Vinyl Chloride, rigid&molding). Thus, the cross section of the beams was specified as a hollow circular cross section with a thickness of 3mm and a diameter of 50mm (measures derived from the selected PVC pipe).

Therefore, after the assembly of the model, it can be analysed. On this purpose, it is important to pay attention to the **utilization** of every beam in the system, which corresponds to the ratio between the normal stress and the yield stress of the material and it is considered acceptable, according to safety rules, as long as is lower than 70%. In this case, the maximum utilization values are equal to 34% for compression (displayed in red) and to 32% for tension (displayed in blue), when the analysis is run with PE as input material. While, when PVC is selected for the simulations, the maximum utilization values are equal to 30% for compression and to 28% for tension.

## Results | PE-HD (Polyethylene, high density)

The structural analyses were useful to gain insight on the structural behaviour of the pavilion, in particular of its ultimate and allowable stresses. Therefore, it was evaluated the normal force in every beam to compute the values of the maximum compression force and the maximum tension force and compare them with the values of the compressive strength and tensile strength of the material.

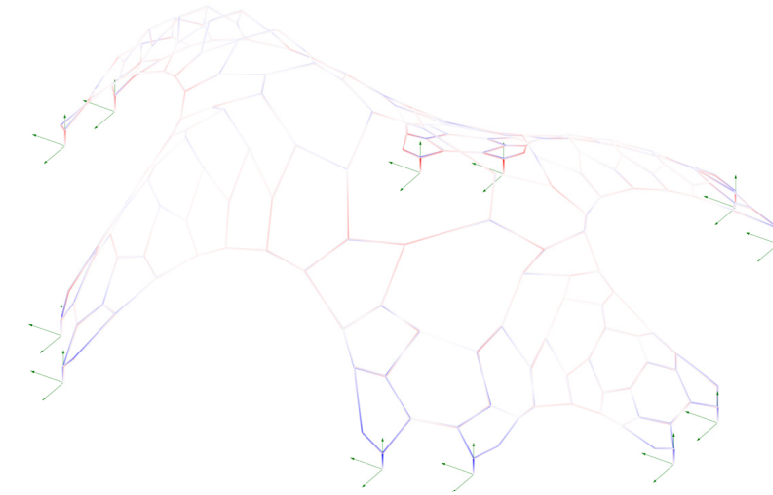

Figure 5.137: Karamba - utilization of the structure (PE) and position of the supports

The analysis determined a maximum compression force of 156.166 N and a maximum tension force of 18.802 N. Hence, the values obtained by the structural analysis are divided by the Area of the cross section of the pipe. Consequently, we can write that:  
Area cross section pipe = 442.965 mm<sup>2</sup>

### COMPRESSION:

PE-HD Compressive strength = 21.7 MPa (average value)  
 $F/A = 156.166 \text{ N} / 442.965 \text{ mm}^2 = \mathbf{0.352 \text{ N/ mm}^2} < \mathbf{21.7 \text{ N/ mm}^2}$

### TENSION:

PE-HD Tensile strength = 26.55 MPa (average value)  
 $F/A = 18.802 \text{ N} / 442.965 \text{ mm}^2 = \mathbf{0.042 \text{ N/ mm}^2} < \mathbf{26.55 \text{ N/ mm}^2}$



Figure 5.138: Karamba - maximum deformation of the structure (PE)



### Results | PVC (Poly Vinyl Chloride, rigid&molding)

The structural analyses were useful to gain insight on the structural behaviour of the pavilion, in particular of its ultimate and allowable stresses. Therefore, it was evaluated the normal force in every beam to compute the values of the maximum compression force and the maximum tension force and compare them with the values of the compressive strength and tensile strength of the material.

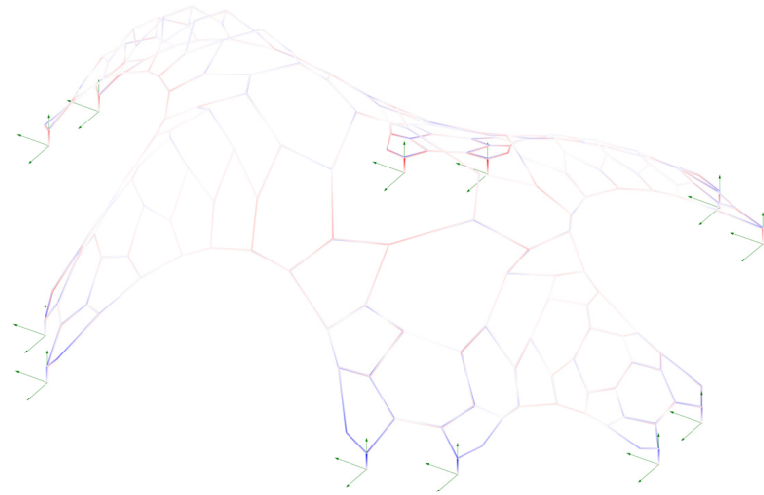

Figure 5.139: Karamba - utilization of the structure (PVC) and position of the supports

The analysis determined a maximum compression force of 227.235 N and a maximum tension force of 27.39 N. Hence, the values obtained by the structural analysis are divided by the Area of the cross section of the pipe. Consequently, we can write that:  
Area cross section pipe = 442.965 mm<sup>2</sup>

#### COMPRESSION:

PVC Compressive strength = 40.65 MPa (average value)

$$F/A = 227.235 \text{ N} / 442.965 \text{ mm}^2 = \mathbf{0.512 \text{ N} / \text{mm}^2} < \mathbf{40.65 \text{ N} / \text{mm}^2}$$

#### TENSION:

PVC Tensile strength = 47.05 MPa (average value)

$$F/A = 27.39 \text{ N} / 442.965 \text{ mm}^2 = \mathbf{0.0618 \text{ N} / \text{mm}^2} < \mathbf{47.05 \text{ N} / \text{mm}^2}$$

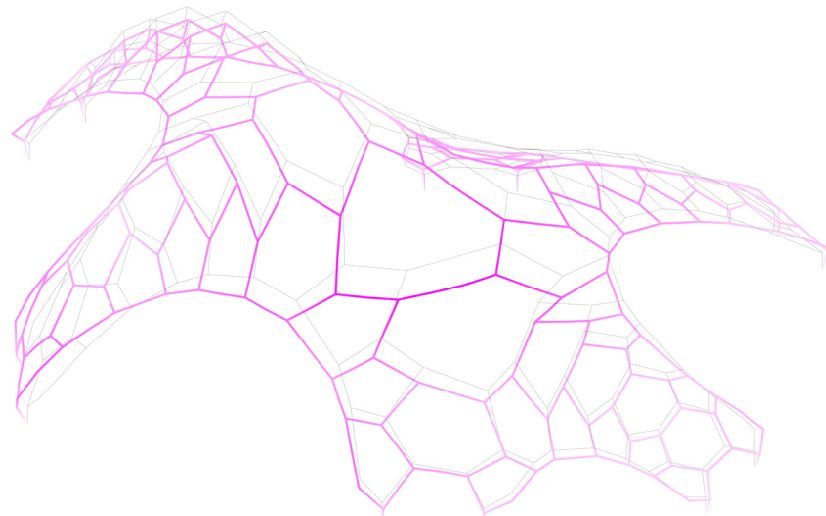
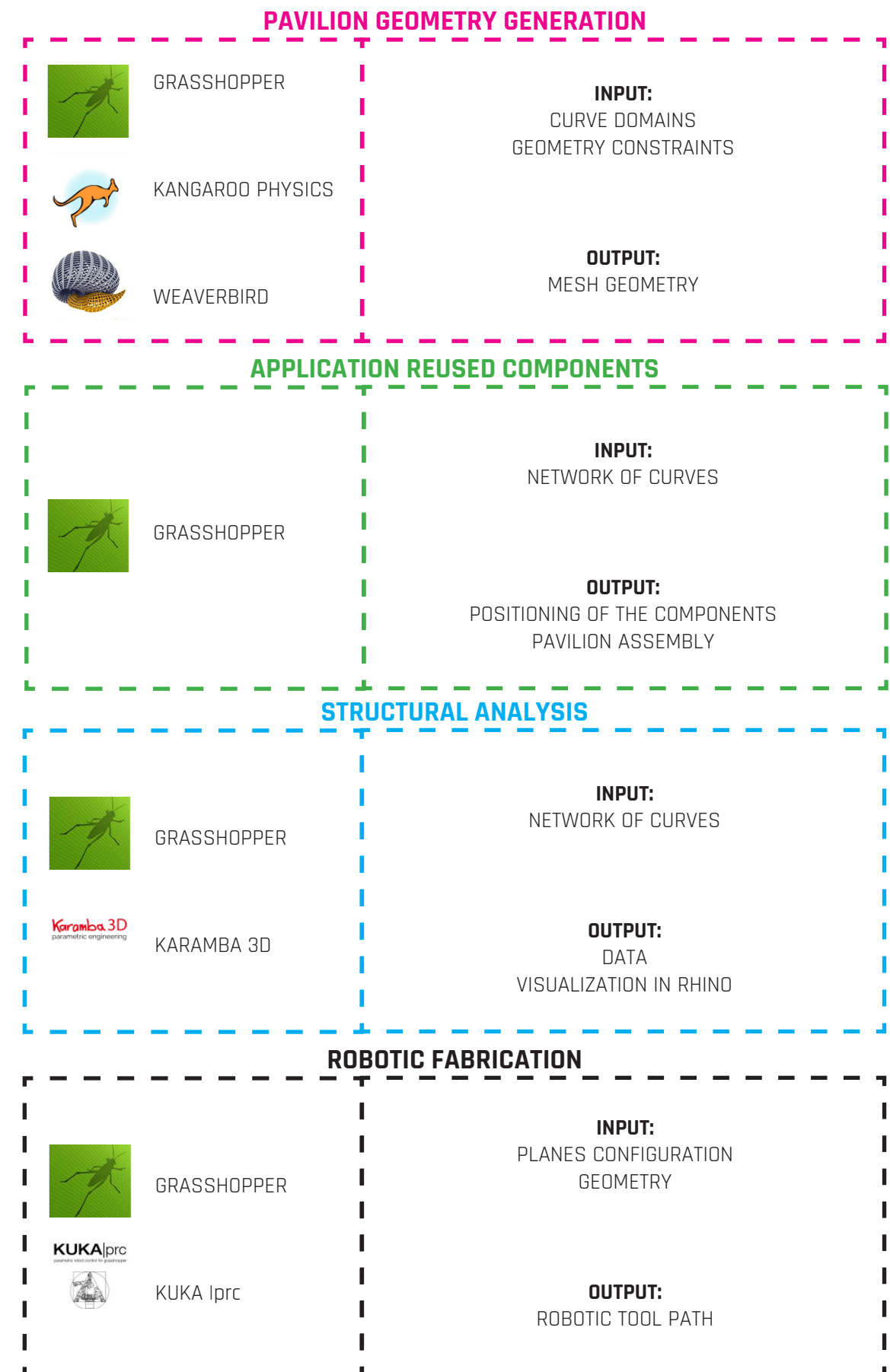
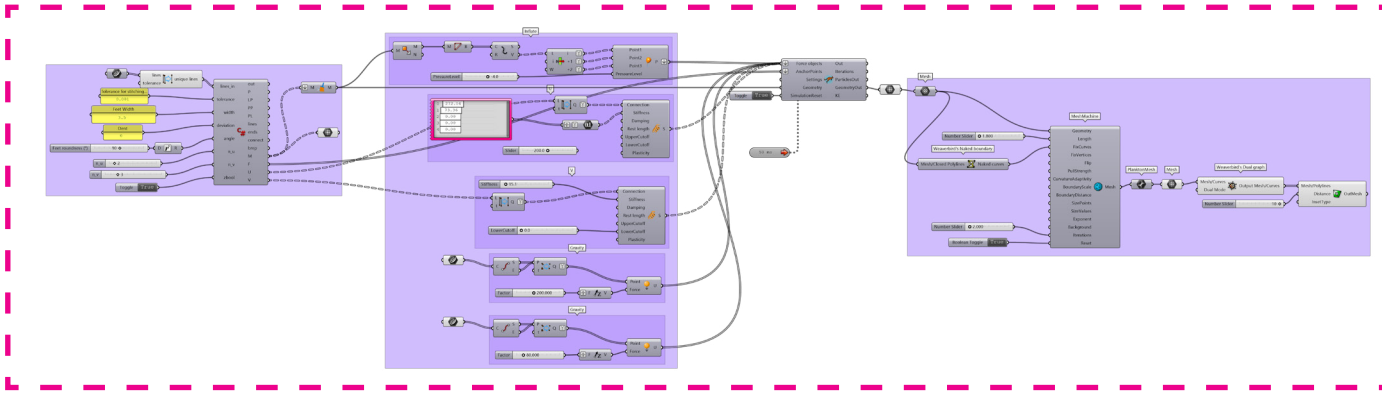

Figure 5.140: Karamba - maximum deformation of the structure (PVC)

## 5.9 Digital work-flow



### PAVILION GEOMETRY GENERATION



### APPLICATION REUSED COMPONENTS

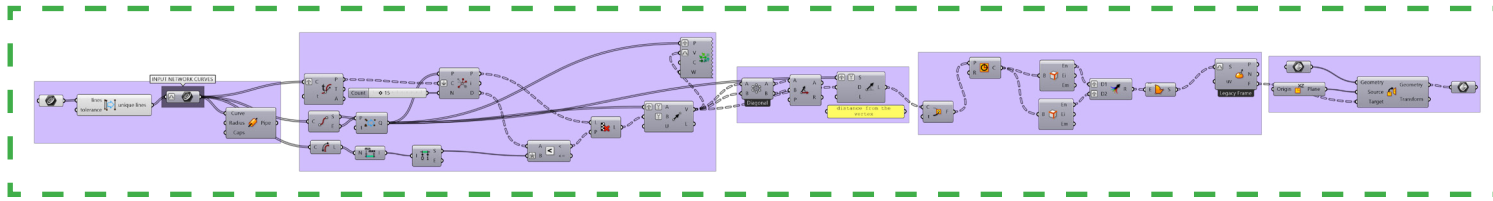

### STRUCTURAL ANALYSIS

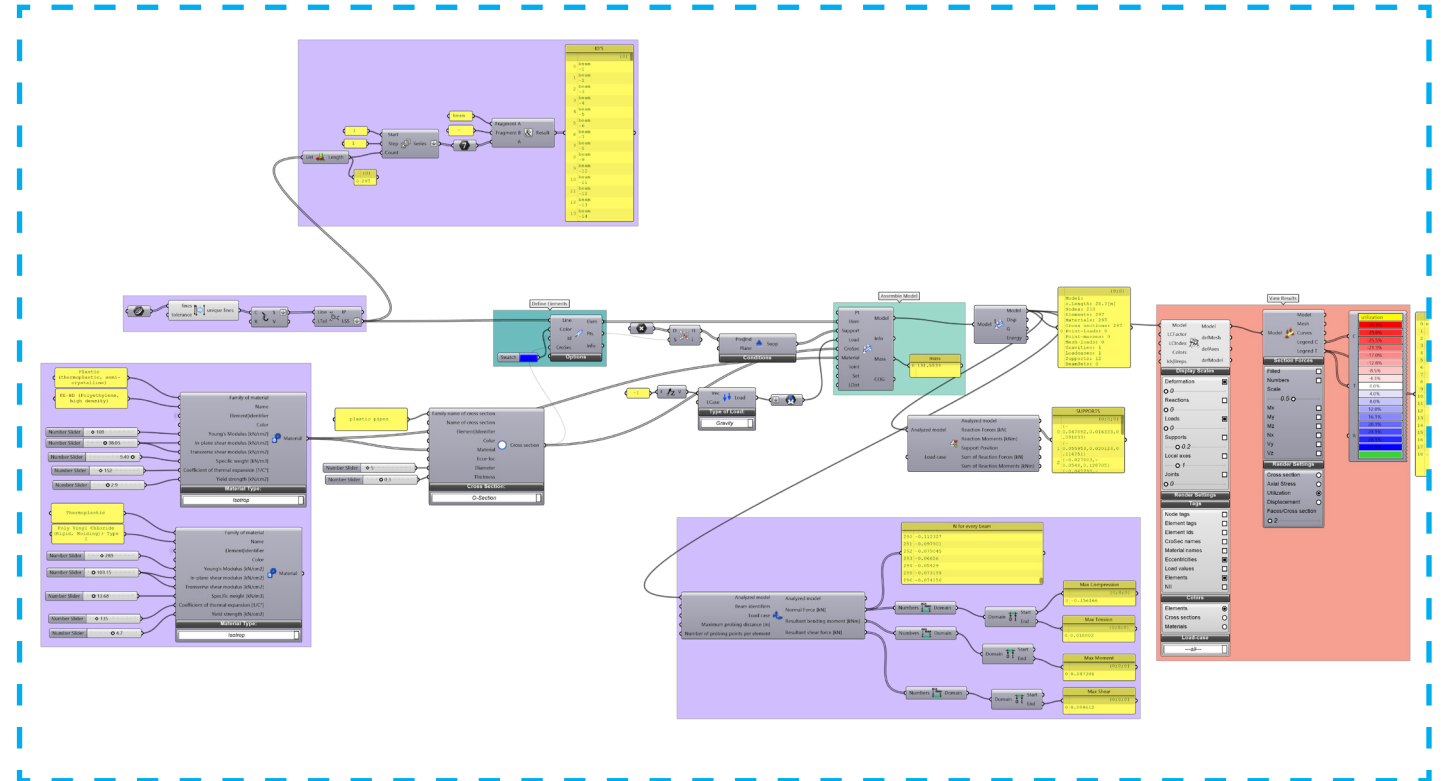

### ROBOTIC FABRICATION - MILLING

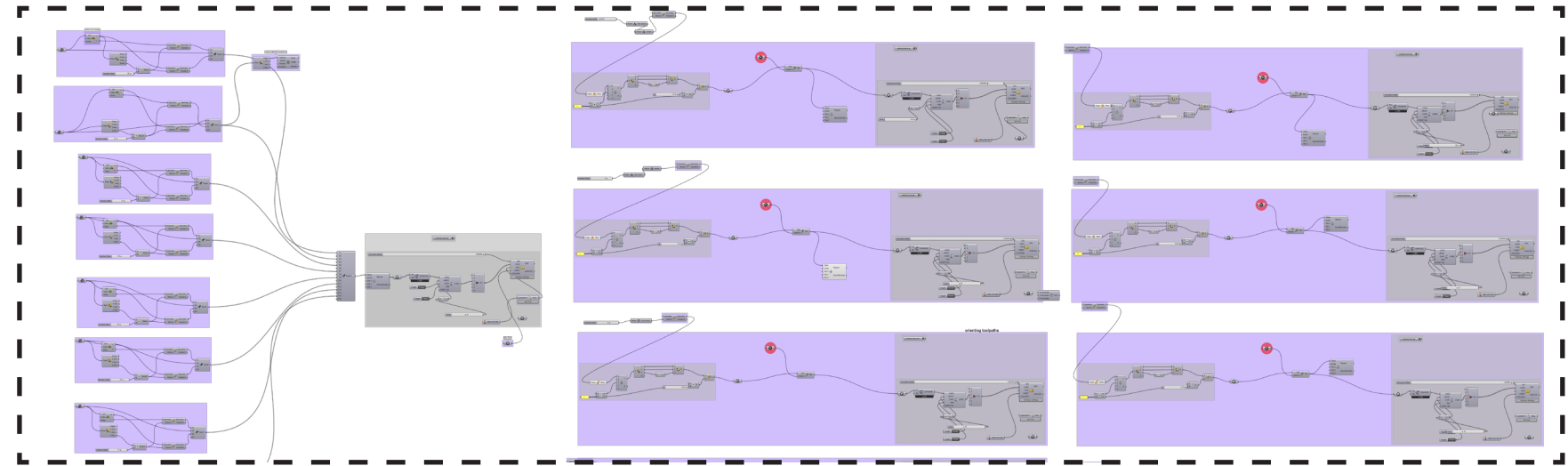

### ROBOTIC FABRICATION - DRILLING

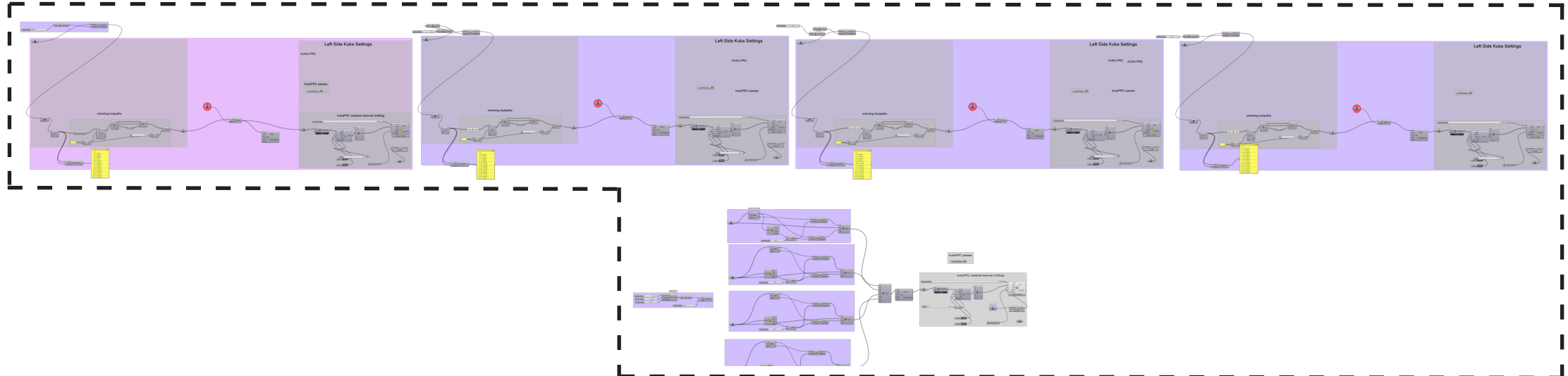

### ROBOTIC FABRICATION - INPUT

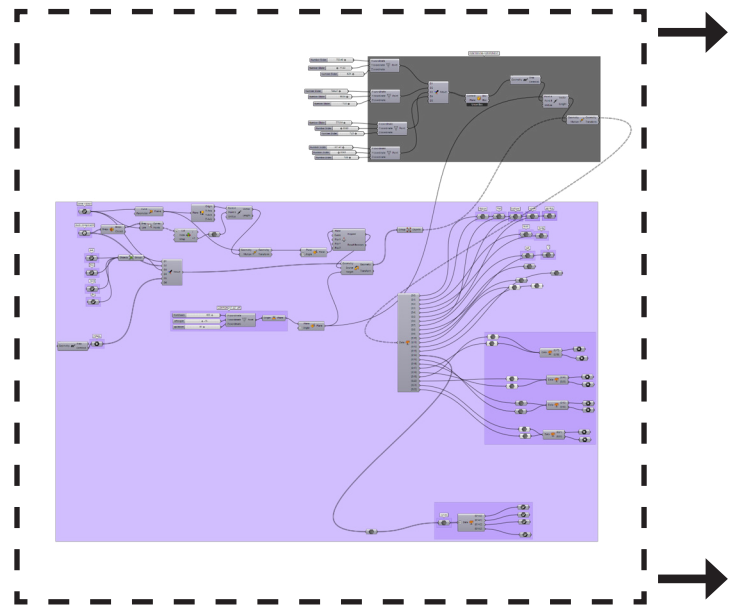



# 6.0 PLANNING AND ORGANIZATION

Calendar Week	45	46	47	48	49	50	51	52	1	2	3	4	5	6	7	8	9	10	11	12	13	14	15	16	17	18	19	20	21	22	23	24	25	26	27	28	29	30	31	32	33	34	35
Course Week	1.10	2.1	2.2	2.3	2.4	2.5	2.6	/	/	2.7	2.8	2.9	2.10	/	3.1	3.2	3.3	3.4	3.5	3.6	3.7	3.8	3.9	3.10	4.1	4.2	4.3	4.4	4.5	4.6	4.7	4.8	4.9	4.10	4.11	5.1	5.2	5.3	5.4	5.5	5.6	5.7	5.8
	P1									P2									P3									P4	SDE Competition								P5						
<b>Research</b>																																											
Literature study																																											
Context analysis																																											
Case studies																																											
Research by design																																											
<b>Focus</b>																																											
Problem statement																																											
Research questions																																											
General Objective																																											
Boundary conditions																																											
<b>Conceptual design</b>																																											
Material scale																																											
Components selection																																											
Pavilion scale																																											
Design idea																																											
<b>Digital design</b>																																											
3D scanning																																											
Script development																																											
Design optimization																																											
Design possibilities																																											
<b>Physical testing</b>																																											
Structural test																																											
Experiment Set-up																																											
D2RP																																											
Comparison																																											
Discussion																																											
<b>Report &amp; Presentation</b>																																											

# 7.0 RELEVANCE

## 7.1 Societal Relevance

Plastic has become the most common material used in the modern economy, because of its practical properties and the low budget needed. Its use increased in the last half-century by twenty-fold and it is expected to increase even more in the coming twenty years. Indeed nowadays, every person around the world is exposed to plastic multiple times during the day on a regular basis.

Moreover, also Catherine Novelli-, the U.S. undersecretary of state for Economic Growth, Energy and the Environment states:

*"Plastic products have an undeniably important role in our society. Plastic waste should not. Not only does plastic waste pollute our land and ocean but the loss of plastic from the current plastic economy is an economic drain. Plastic waste is a problem we can solve and need to solve now. And the solutions are many. Near-term benefits will be made by better waste management and less use, especially single-use, of plastic. But ultimately this problem requires a circular economy approach, where used plastic becomes a feedstock rather than a waste"*

In this context, the research aims to contribute to a sustainable future based on circular economy principles through the employment of reused plastic object in the built environment. In fact, in a world where sustainability aspects are being integrated into several scientific fields, the construction industry plays a highly contributing role. Furthermore, even if the plastic problem has been discussed extensively, it is still not widely embraced by designers through its employment as construction material. Therefore, the value of this graduation project is to underline the role of the built environment in the plastic problem, and most of all to individuate a system in order to make use of reclaimed plastic objects in the architecture field.

## 7.2 Scientific Relevance

From a scientific point of view, the research will provide a reliable methodology to produce complex architectural geometries through the reuse of plastic components in the built environment, in particular on a pavilion scale. Additionally, the study promotes the use of computational design together with D2RP (Design-to-Robotic-Production) technologies to provide a system in order to reuse plastic objects according to their properties, originating a wide range of complex architectural shapes.

Thus, the main innovation of the research is firstly the use of waste components as construction material, even if the knowledge in this field is still lacking, and it still considered easier to build with new materials. Secondly the introduction of D2RP techniques in remodeling and connecting the components, in order to create intricate architectural shapes, or pavilions, avoiding the use of extra material.

# 8.0 REFERENCES

Bell, M. and C. Buckley (2014). Permanent Change: Plastics in Architecture and Engineering, Princeton Architectural Press.

Engelsmann, S., et al. (2012). Plastics: in Architecture and Construction, Birkhäuser.

Bier, H. (2018). Robotic Building, Springer International Publishing.

Kula, D., et al. (2013). Materialogy: The Creative Industry's Guide to Materials and Technologies, Birkhäuser.

Daas, M. and A. J. Wit (2018). Towards a Robotic Architecture, ORO Editions.

Brownell, B. (2013). Material Strategies: Innovative Applications in Architecture, Princeton Architectural Press.

Maas, W., et al. (2015). Barba: Life in the Fully Adaptable Environment, nai010 publishers.

Oosterhuis, K. (2003). Hyperbodies, Birkhäuser.

Addington, D. M. and D. L. Schodek (2005). Smart Materials and New Technologies: For the Architecture and Design Professions, Architectural Press.

Bontempi, E. (2017). Raw Materials Substitution Sustainability, Springer International Publishing.

Colabella, S., D'Amico, B., Hoxha, E., & Fivet, C. (2017). Structural Design with Reclaimed Materials: an Elastic Gridshell out of Skis. Proceedings of the IASS Annual Symposium 2017. Retrieved from <http://infoscience.epfl.ch/record/231033>

Brütting, J., Desruelle, J., Senatore, G., & Fivet, C. (2018). Optimum Truss Design with Reused Stock Elements. Proceedings of the IASS Symposium 2018, Creativity in Structural Design, 8. Retrieved from <http://infoscience.epfl.ch/record/255199>

Freinkel, S. (2011). Plastic: A Toxic Love Story, Houghton Mifflin Harcourt.

Ellen MacArthur Foundation, (2017). The new plastics economy: Rethinking the future of plastics & Catalysing action. Retrieved from <http://www.ellenmacarthurfoundation.org/publications>

World Economic Forum, Ellen MacArthur Foundation and McKinsey & Company,(2016).The New Plastics Economy – Rethinking the future of plastics  
Retrieved from <http://www.ellenmacarthurfoundation.org/publications>

Superuse Studios. "Harvest Map." Retrieved 20/12, 2018, from <https://www.harvestmap.org/>.

Stiho, R., Elektroned, Knauf, Tetris, JLL, TGN, Wavin, steenfabriek Douveren, de Ruttegroep, het NIBE, ABN AMRO en Thinkle. "URBAN MINING COLLECTIVE." Retrieved 10/11, 2018, from <http://urbanminingcollective.nl/>.



Bhada-Tata, Perinaz; Hoornweg, Daniel A. (2012). What a waste? : a global review of solid waste management (English). Urban development series knowledge papers; no. 15. Washington, DC : World Bank Group. <http://documents.worldbank.org/curated/en/302341468126264791/What-a-waste-a-global-review-of-solid-waste-management>

Lave, L. B., et al. (1999). "Municipal Solid Waste Recycling Issues." *Journal of Environmental Engineering* 125(10): 944-949.

ANSYS topology optimisation. <https://www.ANSYS.com/products/structures/optimization>, retrieved in April, 2019.

Addis, B. (2006). *Building with Reclaimed Components and Materials*. London: Routledge.

Testa, P. (2017). *Robot House: Instrumentation, Representation, Fabrication*, Thames & Hudson.

Boehler, W., Heinz, G., Marbs, A., 2001: The potential of noncontact close range laser scanners for cultural heritage recording, XVIII. CIPA Symposium, Potsdam, Germany, Proceedings. Retrieved 31/12, 2018, from <http://www.i3mainz.fh-mainz.de>.

Lasi, H., Fettke, P., Kemper, HG. et al. *Bus Inf Syst Eng* (2014) 6: 239. <https://doi.org/10.1007/s12599-014-0334-4>

Preisinger, C. (2013), Linking Structure and Parametric Geometry. *Archit Design*, 83: 110-113. doi: 10.1002/ad.1564.

CES Edupack 2018 (Granta Design Limited, 2018)

Self, M., Walker, C., & Architectural Association School of Architecture. (2011). *Making pavilions: AA Intermediate Unit 2 2004-09*. London: AA Publications.

Oosterhuis, K. (2012). *Hyperbody: First decade of interactive architecture*. Heijningen: Jap Sam Books.

Weisstein, E. (2002), *CRC Concise Encyclopedia of Mathematics*, 2nd ed., CRC press.

Berkel, B. ., Bos, C., & Roberts, N. (2016). *Knowledge matters*. Amsterdam: Frame Publishers.

Rob/Arch: Robotic Fabrication in Architecture, Art, and Design (Conference), & In Willmann, J. (2019). *Robotic Fabrication in Architecture, Art and Design 2018*.

Weißbarth, D. (2016). *Robotic fabrication in architecture, art and design 2016*.

Testa, P. (2018). *Robot house*, Thames & Hudson Ltd, 2018.

# 9.0 REFLECTION

## 9.1 Graduation Topic

It is known that the global impact of solid waste is becoming more worrying day by day; however, the application of reused materials in the built environment is not yet fully embraced. In particular, plastic composites are now fundamental for the global world economy but the organization of their end life needs to be improved.

Therefore, the research will investigate the possibility of reusing plastic in the built environment through means of robotic production and computational design. In fact, the research combines two fields within the Building Technology track (Design Informatics and Structural Design) to explore different design possibilities based on reclaimed plastic objects, testing their structural stability and modifying them through robotic fabrication. In order to create a design system for a pavilion made of reclaimed materials, based on a computational workflow.

The relationship between the research project and the two studio where is placed in, the "*Sustainable Design Graduation Studio*" and the "*Robotic Building studio*" is mostly evident in both cases.

In the first case, the creation of a system for the construction of a pavilion based on the reuse of reclaimed plastic objects is following the circular economy principles of reducing, reusing and recycling. In fact, considering that the world plastic request is constantly increasing, the current research about the plastic problem is on two levels. The first one is the replacement of oil into the manufacture of plastic materials by renewable bio-sourced materials and the second is the organization of the end life of these plastics through recycling or reusing the products. Hence, this research aims to the reduction of plastic waste by its utilization in the built environment. In fact, it was discovered that objects not designated to be construction components can be modified and commute into one, which could have a big impact on the amount of existing plastic waste, if the system would be applied on a larger scale.

In the second case, once again the connection is clear because robotic fabrication is the main instrument of the design. Indeed it is possible, thanks to a computational workflow and Design-to-Robotic-Production (D2RP) methods, to create a system that could be applied to many different geometries, allowing a considerable amount of freedom in the design and avoiding randomness.

To conclude, rather than employing new resources in the fabrication of a pavilion structure, the research promotes the use of reclaimed material, reversing the design process. Instead of designing a shape and consequently choose a material, the design will start from the choice of a reclaimed material and the analysis of its potential, in order to originate a structure according to them. Besides the research project aims to facilitate the process through the creation of a system that can be applied to multiple reclaimed objects and shapes.

## 9.2 Graduation Process

The first part of the research process was focused on the research of possible components to use in the design. The research turned out to be less simple than imagined, in fact even though many different locations were visited; only one location resulted helpful for the selection of the components.

This phase was also characterized by the analysis of the structural strength of the components, where a physical approach carried on by tests in the laboratory was needed to select the ones suitable for the design and for the robotic modification process. During the first phase it was also conducted a research through existing case studies; however the research was found to be scarce because the majority of the case studies found and analysed were part of an artwork or were realized through the repetition of a single object instead of multiple ones. Moreover, in various case study, even if it can still be appreciated the idea of repurposing an object, the components used in the design were not reclaimed materials but existing objects that can be mass produced (such as plastic hammers, used in the GIRA case study or plastic seats like in the Gallery of furniture project).

After the first phase of analysis, it was possible to establish the different requirements that the final product should fulfil, together with the delimitations of the boundary conditions. It was in fact understood that the most realistic scale for the research could not be the one of a building but the one of a temporary pavilion that could be used in events thanks to its demountable feature. This phase also led to the formulation of different research questions that guided the all research process. In this context, it was also necessary to start to get a deeper understanding of the different typologies of plastic as a material, to predict its behaviour and be able to select the best connection processes. However due to the lack of existing research material regarding plastic modification in order to repurpose an object and most of all through means of robotic fabrication; multiple physical attempts by prototyping were needed to select the best connection method.

On this purpose, during the Computational Design phase, it was developed a computational design system that could tessellate every possible shape, placing the joints based on the drill container components, at the vertex of the tessellation. After the set-up of the computational system, it was possible to collect different configurations of joints to prototype and analyse. The amount of precision required to be able to perform the connections between the elements of the joint represented the greatest challenge of the research. In fact, to accomplish the robotic modification of the components according to the design, it was necessary to produce a highly accurate 3D model of the existing object, in order to establish a robotic tool path to cut the components always perpendicular to the cut surface to be able to reach the amount of precision needed in the design.

One of the limitations of the robotic modification was, as already stated, the necessity of a highly accurate 3D model of the existing object in order to be able to match the robotic simulation with the robotic milling in the real environment. Indeed, because of the inaccuracy of first 3D model used, the time required for the robotic cutting of the first prototype was much longer than expected; due to the necessity of updating the robotic tool path multiple times to approximate the position of the curve in the real environment. Moreover referencing the object between the simulation and the real environment was also challenging because the referencing can be imprecise.

In a second phase of the research, it was possible to 3D scan the existing object and obtain a highly accurate model of the component, model that made the all process of prototyping much faster. Therefore, it was possible to produce the robotic tool path in less time, and to dedicate some time to the testing of different joint connections, to evaluate the best method to connect the components and the correct configuration between them.

However, considering the time needed to figure out the joint connection that at the beginning was meant to be welded together, while after a deeper analysis of the material and its possible connections, did not result an optimum solution, therefore a more complex connection had to be performed. The pavilion scale design was less deeper developed and a smaller amount of prototypes were produced, compared to what envisioned at the beginning. Furthermore, the final result of the research had to be scaled down to be able to improve as much as possible the joint itself that, from a research point of view, is the most relevant part of the structure. Indeed, from the initial idea of building the complete structure of the pavilion on campus, it was decided to focus on building a 1:1 prototype of the selected portion of the structure and to split the research in different scales. The micro scale for the analysis of the properties of the material, the meso scale for the detailed fabrication of the joint and the macro scale, for the design of the overall pavilion structure.

## 9.3 Societal Impact

The use of reclaimed materials is often associated to an old practice and with something that has no relation with the new advancements in the technology field and that cannot produce a pleasant aesthetic.

On this purpose, the research stimulates the application of reclaimed materials in a non-conventional and innovative way, establishing a connection between the concept of reusing materials and the use of new technologies, instead of considering it an old practice. Furthermore, the research questions the actual perception of what can be considered as a construction material, which should not include anymore only concrete, bricks, etc... but whatsoever component suitable to be used as building component even if for smaller scales application, such as pavilions.

The project also provides a method that allows great flexibility in the design, challenging the idea that reclaimed materials do not offer enough freedom to design complex structures. Flexibility that can be obtained taking advantage of the fourth technology advancement (Industry 4.0), in order to be able to robotically modify objects, reaching a higher level of complexity in the design.

The above mentioned method of construction can be applied not only for pavilion designated for events but also for summer pavilions in relation with an activity already existing in the city (such as bar, restaurant, etc...) or even be used as urban furniture. Indeed the use of reclaimed plastic objects as building components, even if only for temporary building, would lead to the gradual decrease of the amount of plastic waste from a smaller to a larger scale and at the same time create people awareness regarding the plastic problem.

Concluding, for the research project to be directly applicable in practice, additional studies would have to be carry out regarding the stability of the overall pavilion structure, that can lead to the construction of a pavilion on a small scale and depending of its behaviour could lead to the use of the system on a larger scale.



# 10.0 CONCLUSION

## 10.1 Main research question

*How can we reuse plastic objects in the building industry in order to contribute reducing the problem of plastic waste and its share of global oil consumption?*

Plastic composites represents one of the biggest environmental issues today and despite the economic crisis, the world plastics request is continuously increasing. Therefore, the research does not aim to solve the problem of plastic waste, which needs to be carried out on different levels, but to contribute in reducing the problem, setting an example to demonstrate that also the building industry could contribute to the cause, increasing at the same time people awareness about it.

Accordingly, it was developed a system in order to fabricate pavilions that could be used for different functions, made entirely of reclaimed materials. The system is based on the idea of tessellating the desired shape, placing the joints based on the drill container components together with the laboratory ware component, at the vertex of the tessellation. Consequently, the drill components are connected together through the water pipe components and then a plastic foil is placed over the structure. Obviously, it needs to be considered that when designing with reclaimed materials the process becomes slower because the aim is to use nearly zero extra material. As a result, it will not be possible to directly search for a beam when needed, but the design needs to be carried out in order to search for a component that could function as a beam.

Hence, the design process becomes much slower and it is also limited in terms of size of the structure, as well as the functions that the structure could host. The most realistic solution to reuse plastic objects in the building industry, according to the system developed during the research is to make use of reclaimed plastic objects to build pavilion structures, in order to replace temporary structures such as tents or summer pavilions.

## 10.2 Sub research questions

*How can we elongate the life of a plastic product avoiding the use of new materials and applying it to the built environment?*

*How could we use plastic objects in an upcycle scenario?*

The aim of this study is to build a system for the construction of a pavilion based on reused plastic components, in order to elongate the life of a product otherwise designated to end up in a landfill. In order to do so is necessary to analyse and test the potentials of the components to understand if they are suitable to be used for the construction and in that case, determine which function they could serve in it.

It is also relevant to notice that the majority of the components will not be suitable for construction purposes, reason why the initial selection of the components is particular important for the success of the construction of the pavilion. Naturally, to originate a structure that is based on the idea of elongating the life of plastic products, it does not make sense to use reclaimed components that are not suitable for the construction so they need to be reinforced with new materials. Therefore, even the connection between them should be performed making use of other reclaimed materials or, as it is done in the research, modifying the object itself to use a part of it as a connection element.

The research actually indicates how to use plastic objects in an upcycle scenario for the construction of temporary structures of medium dimensions, upcycling the waste plastic objects and at the same saving the material that would be used for the construction of those structures.

*Which requirements do the plastic components need to have to be used for the construction of the pavilion?*

There are different requirements that a plastic component should to have to be used for the purpose of the study.

One of the most important requirements is the difficulty in reusing the component in daily life, for example, a plastic vase would be discarded from the selection because it has a clear function and it could be easily reused. However, in case the object cannot be reused with its original function because it is damaged, it probably will not be suitable for the design either, in fact because of being damaged, it probably lost already some of its strength. Consequently, it is preferable to retrieve the components directly from the company that wants to dismiss them instead of from a waste company.

Another requirement that needs to be analysed is the strength and the behaviour of the component during the structural test, in fact it is preferable a component that shows a ductile behaviour compared to a brittle one. However is not possible to delimitate a minimum strength that the component should have because it also depends on how the components are connected, because if more components are combined together, they will also share the load.

To conclude it is preferable a component that has a volumetric closed shape because it results more suitable for construction purposes, together with a wall thickness of at least 1mm, in order to be able to modify it with D2RP techniques.

*What strategies can be adapted to connect the plastic components with each other without the use of extra material?*

There are many strategies that can be adopted for the connection of plastic components and during the course of the research, many options related to the idea of using nearly extra material were considered.

The first option, as well as the more obvious one, is welding that being a thermal process, in the case of plastic could lead to cracking or shrinking of the components. Therefore, similar options that do not require a thermal process were considered, such as solvent bonding, the use of an adhesive connection or glue.

Other strategies related to the use of a mechanical connection were also considered, for example using an L shape element and connecting the pieces with bolts or using tie wraps after drilling the holes. It was eventually considered even to place a vacuum bag around the components forming the joint.

Based on the study, the best option seemed the use of a mechanical connection based on the idea of removing and folding parts and connecting them through nuts and bolts. In fact it would avoid the use of extra material, using the interlocking parts, otherwise removed, as a connection. The main idea was, for every component, to cut one side of the interlocking part and to fold the other. In a way that the folded part of one component would fit perfectly into the cut part of another component, working as a connection, secured then by nut and bolt.

*How can computational design and 3D scanning assist the designer in ideating a construction system based on reused components?*

The role of computational design in the research is mainly related to aspects like simulation, optimization, and fabrication. In fact, thanks to computational design it is possible to build a workflow that can be applied to many different shapes, to find the structure that fits best with the reused components. The designer has now the possibility to move a step forward from traditional geometry and to achieve geometry complexity even in a construction based on reused components, enhancing the design accuracy of it. Hence, if a digital model is parametrically optimized, it is possible thanks to digital fabrication to realize a physical prototype of the exact same geometry, in order to test the performance of parts of the structure. For example, thanks to computational design it was possible, during the study, to test different solutions for the joints only changing some parameters in the workflow.

During the second phase of the research, based on the study it was drawn the conclusion that 3D scanning is certainly not the focus of the research but it is necessary for its progression. In fact working with a precise and detailed model of the selected object is an important starting point to assist the designer in the robotic modification of the components, because it makes the process faster and more accurate. Thus it was clear that to reach a higher level of accuracy in the 3D model, and have a better approximation of the real object, it was necessary the use of a 3D scanner. Consequently, the fabrication process of the single components for the joint became much faster and optimized.

*How can robotic fabrication aid to the reuse of plastic components?*

Robotic fabrication was necessary for the development of this graduation project because it facilitates the creation of a feedback loop between the digital design and the 1:1 scale prototype. In fact, starting from the 3D model, obtained by the computation workflow, it was possible to convert the design into a robotic tool path in order to transform the reclaimed plastic objects and physically realize the researched design.

Indeed, thanks to robotic fabrication, the components can be cut at a specific optimum angle in an extremely precise and accurate way. Besides, for the complexity of the design developed during the research, all the components that form the connections need to be custom cut at a specific angle, thus the use of robotic fabrication will make the process more accurate and faster compared to traditional methods.

Moreover, thanks to D2RP methods, it is possible to realize complex architectural shapes even if using reclaimed plastic objects, in fact the freedom in the design is not lost thanks to the possibility of modifying the existing object according to the shape of the structure. Avoiding at the same time the use of extra material thanks to the possibility of cutting parts of the existing components in order to them as connection elements.

*What are the limits in shape and geometry when reusing objects and how can robotic fabrication help us to overcome them?*

Based on the outcome of the study it is possible to define the limits that characterize a structure based on reclaimed components. In fact, even if a pavilion scale and in particular a temporary structure has certainly fewer constraints compared to a building, some requirements are still needed to be considered, such as the demountable feature, the application of nearly zero extra material as well as the size of the pavilion that cannot have large dimensions. Moreover, it is important to consider the stability of the structure, which is more complex to analyse compared to a traditional building and its weathering behaviour.

Moreover in terms of freedom in design, shape, and geometry, using reclaimed components that were not entitled to be construction materials, requires from the architect more flexibility in finding a compromise between the overall design idea and the usage of existing objects. However, as already stated above, the use of robotic fabrication allows more freedom in the design because every component can be custom cut, in order to reach the desired shape for the structure.



# 11.0 APPENDIX A



Figure 5.29: disposable keg test 1

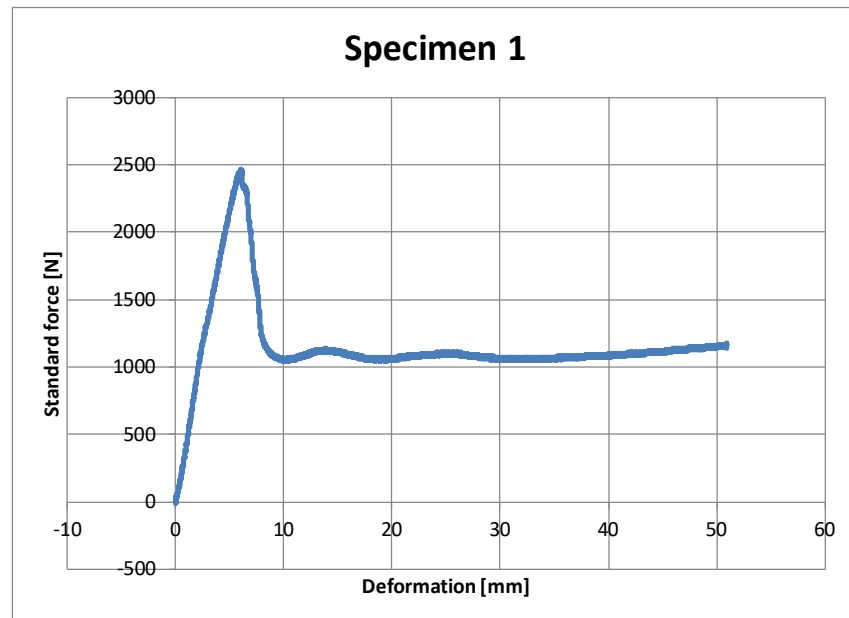

Figure 9.1: disposable keg test 1 - first loading

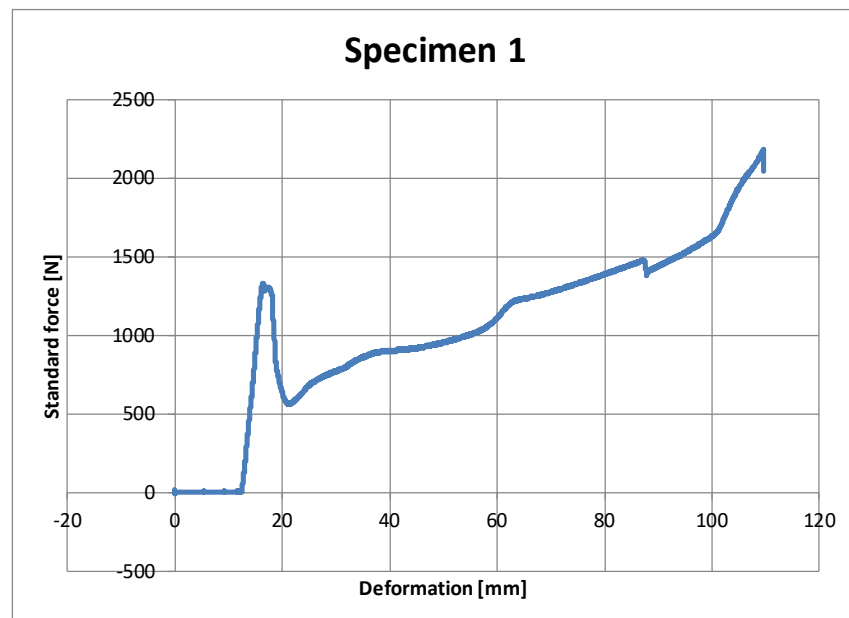

Figure 9.2: disposable keg test 1 - second loading

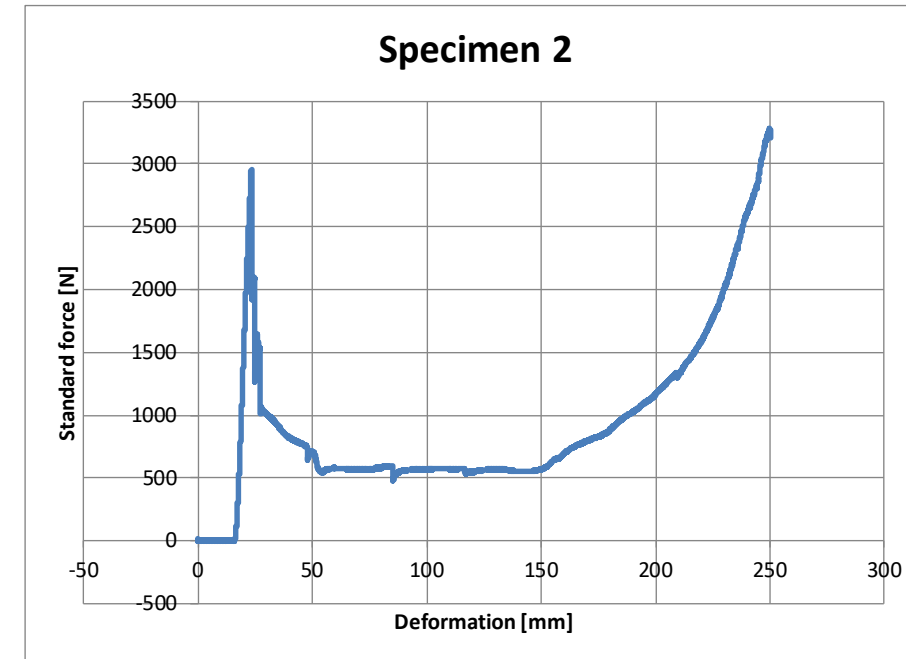

Figure 9.3: disposable keg test 2 - first loading



Figure 5.30: disposable keg test 2

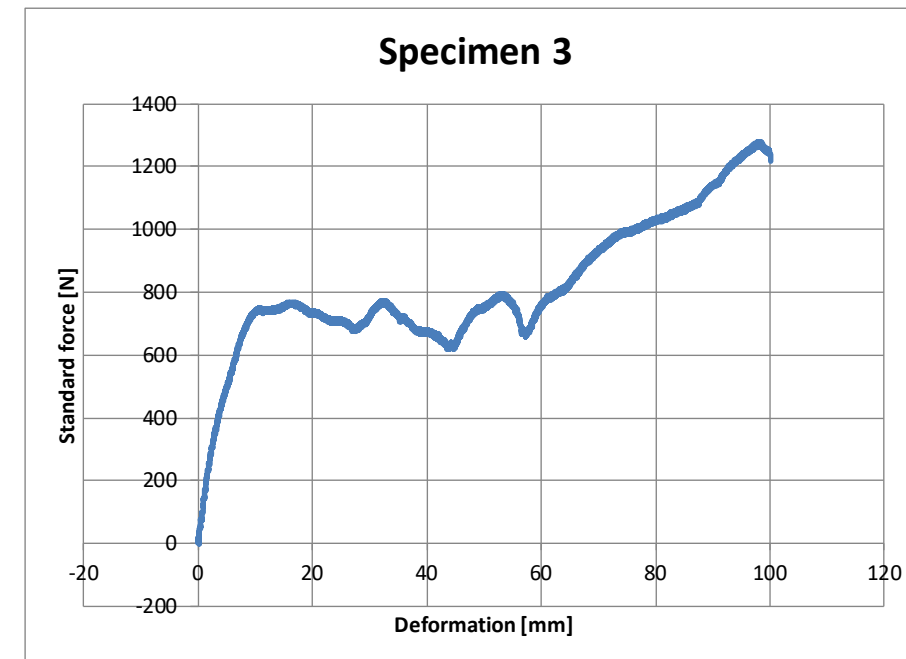

Figure 9.4: drill container test 3 - first loading



Figure 5.31: drill container test 3

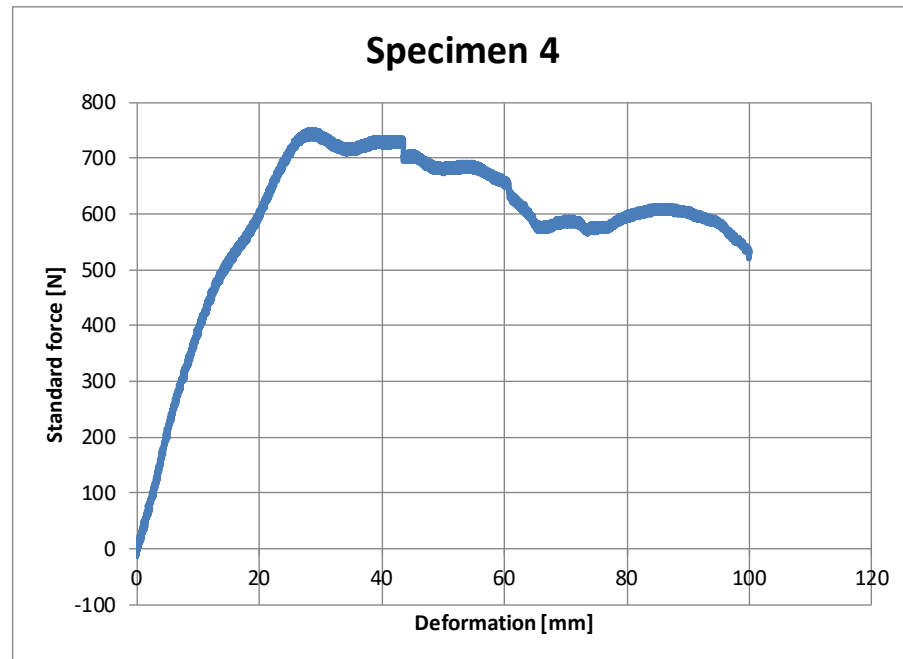

Figure 9.5: stacked drill containers test 4 - first loading



Figure 5.32: stacked drill containers test 4

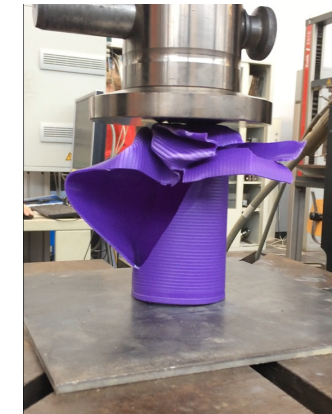

Figure 5.34: violet cone test 6

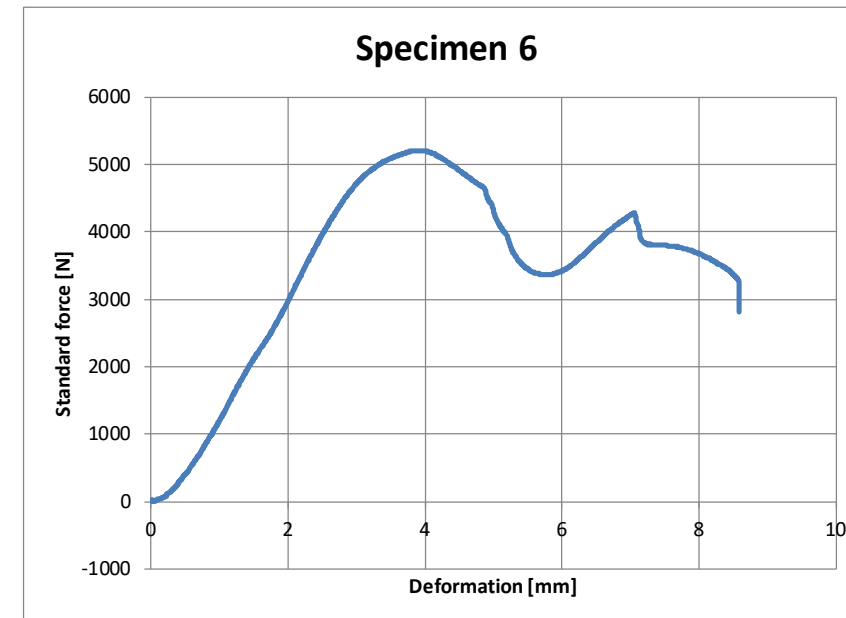

Figure 9.8: violet cone test 6 - first loading

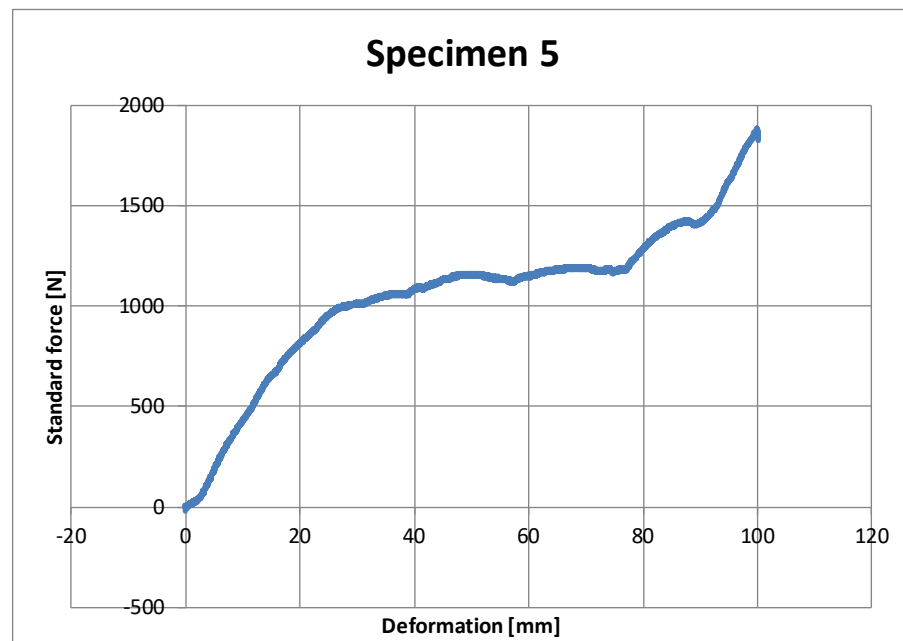

Figure 9.6: drill container bottom component- retrieved from previous test test 5 - first loading



Figure 5.33: drill container bottom component retrieved from previous test

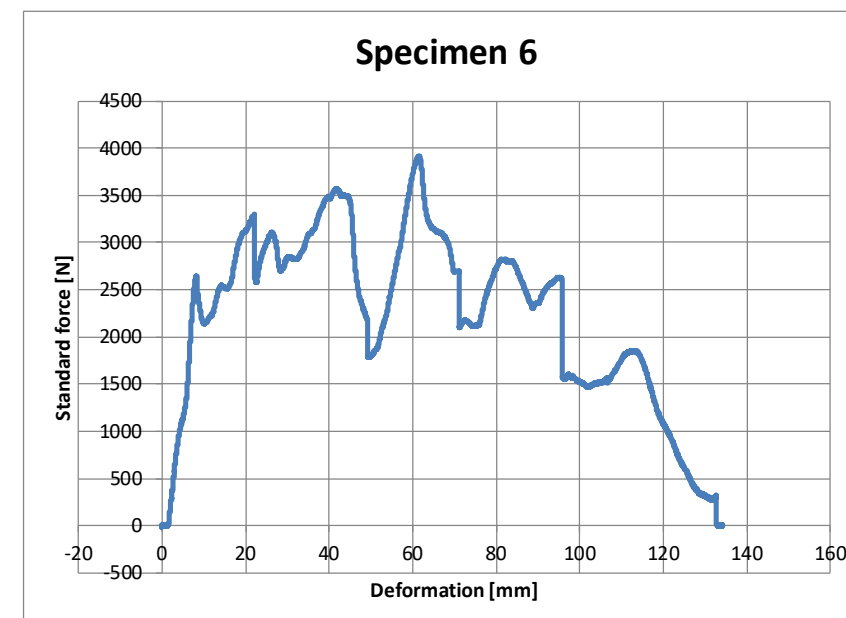

Figure 9.9: violet cone test 6 - second loading



# 12.0 APPENDIX B

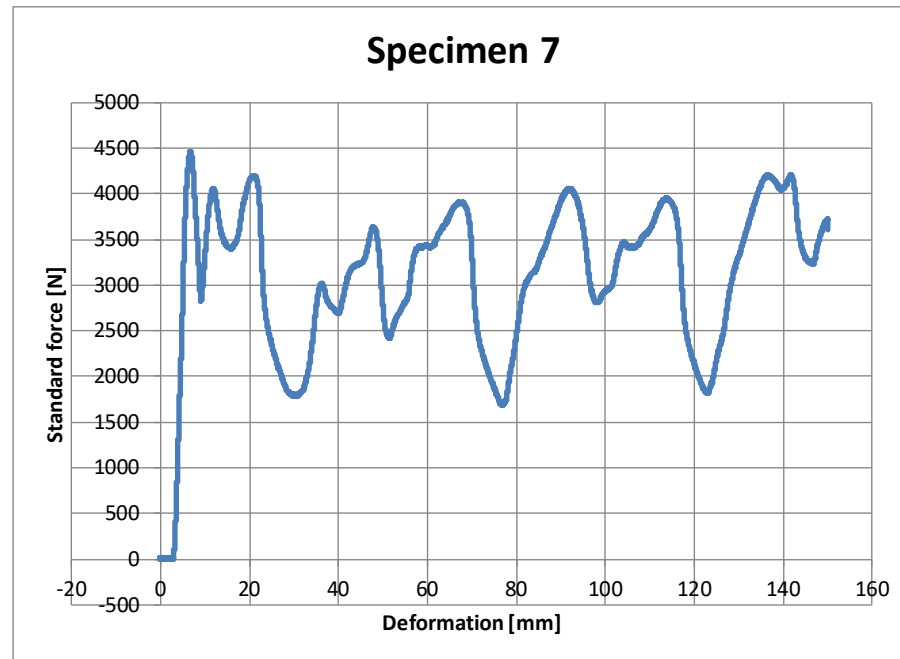

Figure 9.10: gray cone test 7 - first loading perfect buckling



Figure 5.35: gray cone test 7 perfect buckling

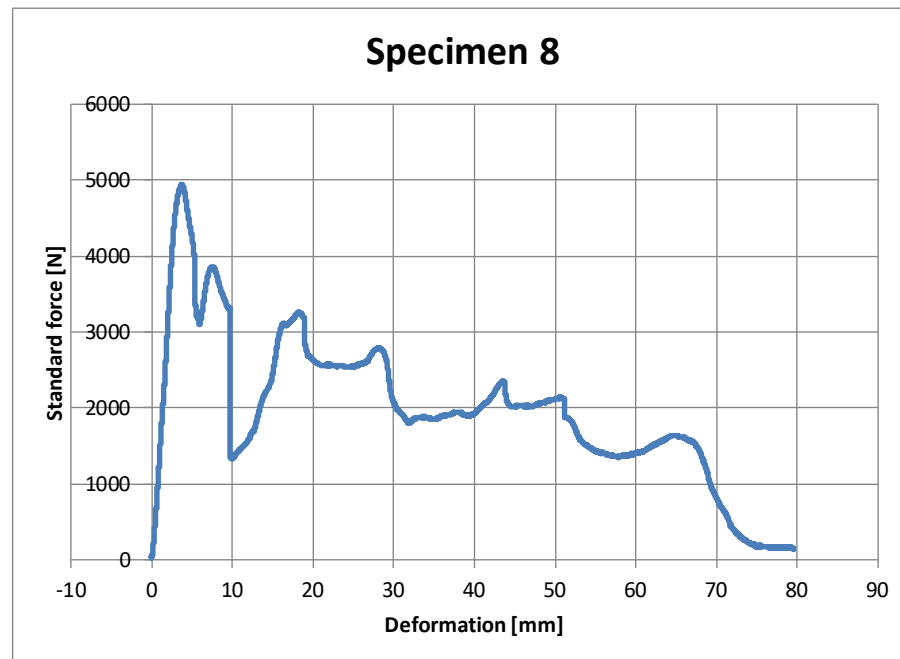

Figure 9.11: green cone test 8 - first loading



Figure 5.36: green cone test 8

## General information

### Designation

High density polyethylene / HDPE (homopolymer)

### Tradenames

Accucomp, Alathon, Alcludia, Arak, Asrene, Axeleron, Bapolene, Borcell, Borcoat, Borealis, Bormed, Borpex, Borsafe, Borstar, Bretene, Certene, Colorr, Continuum, Daelim, Delta, Dow Health+, Dowlex, Egyptene, Eleme, El-Lene, Eitex, Eraclene, Etilinas, Evalene, Evolve-H, Exelene, Formolene, G-Lene, G-Lex, Halene, Hanwha, Hiplex, Hival, Hivorex, Hi-Zex, Hostalen, Hypel, Icorene, Indothene, Ineos, Innoplus, J-Rex, Kazan, Kemcor, Lanufene, Lumicene, Lupolen, Lutene, Marflex, Marlex, Marpol, Midilena, Mtegrity, Neftekhim, Nexus, Novapol, Novatec, Paxon, Petilen, Petrothene, Plexar, Polimaxx, Polycompo, Ponacom, Primatop, Prixene, Purell, Qenos, Quadrant, Ravago, Relene, Rigidex, Sabic Vestolen, Safrene, Samsung Total, Sclair, Seetec, Snolen, Surespec, Surpass, Taborex, Taisox, Tipelin, Titanex, Titanvene, Titanzex, Toler, Total, Unilex, Unithene, Unival, Venelene, Vestolen, Yanshan, Yuclair, Yuhwa, Yuzex

### Typical uses

Pipes, toys, bowls, buckets, milk bottles, crates, tanks, containers, film for packaging, blown bottles for food.

## Composition overview

### Compositional summary

(CH<sub>2</sub>CH<sub>2</sub>)<sub>n</sub>, typical n=10,000-20,000

Material family	Plastic (thermoplastic, semi-crystalline)
Base material	PE-HD (Polyethylene, high density)
Polymer code	PE-HD

### Composition detail (polymers and natural materials)

Polymer	100	%
---------	-----	---

### Price

Price	* 1,45	- 1,51	EUR/kg
Price per unit volume	* 1,39e3	- 1,45e3	EUR/m <sup>3</sup>

### Physical properties

Density	952	- 965	kg/m <sup>3</sup>
---------	-----	-------	-------------------

### Mechanical properties

Young's modulus	1,07	- 1,09	GPa
Specific stiffness	1,11	- 1,14	MN.m/kg
Yield strength (elastic limit)	26,2	- 31	MPa
Tensile strength	22,1	- 31	MPa
Specific strength	27,3	- 32,4	kN.m/kg
Elongation	1,12e3	- 1,29e3	% strain
Compressive modulus	* 1,07	- 1,09	GPa
Compressive strength	* 18,6	- 24,8	MPa
Flexural modulus	0,997	- 1,55	GPa
Flexural strength (modulus of rupture)	* 30,9	- 43,4	MPa
Shear modulus	* 0,377	- 0,384	GPa
Bulk modulus	* 2,15	- 2,26	GPa
Poisson's ratio	* 0,41	- 0,427	
Shape factor	4,6		

Values marked \* are estimates.  
No warranty is given for the accuracy of this data

Hardness - Vickers	* 8	- 10	HV
Hardness - Rockwell M	* 31	- 35	
Hardness - Rockwell R	* 45	- 55	
Elastic stored energy (springs)	320	- 442	kJ/m <sup>3</sup>
Fatigue strength at 10 <sup>7</sup> cycles	* 8,84	- 12,4	MPa

#### Impact & fracture properties

Fracture toughness	* 1,52	- 1,82	MPa.m <sup>0.5</sup>
Toughness (G)	2,15	- 3,04	kJ/m <sup>2</sup>
Impact strength, notched 23 °C	6,14	- 18,6	kJ/m <sup>2</sup>
Impact strength, notched -30 °C	3,33	- 16,3	kJ/m <sup>2</sup>
Impact strength, unnotched 23 °C	590	- 600	kJ/m <sup>2</sup>
Impact strength, unnotched -30 °C	590	- 600	kJ/m <sup>2</sup>

#### Thermal properties

Melting point	130	- 137	°C
Glass temperature	-125	- -90	°C
Heat deflection temperature 0.45MPa	79	- 91	°C
Heat deflection temperature 1.8MPa	* 44	- 77	°C
Maximum service temperature	113	- 129	°C
Minimum service temperature	-82	- -72	°C
Thermal conductivity	0,461	- 0,502	W/m.°C
Specific heat capacity	1,75e3	- 1,81e3	J/kg.°C
Thermal expansion coefficient	106	- 198	µstrain/°C
Thermal shock resistance	132	- 250	°C
Thermal distortion resistance	* 0,00243	- 0,00454	MW/m

#### Electrical properties

Electrical resistivity	3,3e24	- 3e25	µohm.cm
Electrical conductivity	5,75e-24	- 5,22e-23	%IACS
Dielectric constant (relative permittivity)	2,2	- 2,4	
Dissipation factor (dielectric loss tangent)	4e-4	- 6e-4	
Dielectric strength (dielectric breakdown)	17,7	- 19,7	MV/m
Comparative tracking index	600		V

#### Magnetic properties

Magnetic type	Non-magnetic
---------------	--------------

#### Optical, aesthetic and acoustic properties

Refractive index	1,53	- 1,55	
Transparency	Translucent		
Acoustic velocity	1,06e3	- 1,07e3	m/s
Mechanical loss coefficient (tan delta)	* 0,0367	- 0,0374	

#### Critical materials risk

Contains >5wt% critical elements?	No
-----------------------------------	----

#### Absorption & permeability

Water absorption @ 24 hrs	0,005	- 0,01	%
---------------------------	-------	--------	---

Values marked \* are estimates.  
No warranty is given for the accuracy of this data

Water vapor transmission	0,0283	- 0,0425	g.mm/m <sup>2</sup> .day
Permeability (O2)	49,8	- 69,4	cm <sup>3</sup> .mm/m <sup>2</sup> .day.atm

#### Processing properties

Polymer injection molding	Excellent
Polymer extrusion	Excellent
Polymer thermoforming	Excellent
Linear mold shrinkage	1,5 - 4 %
Melt temperature	177 - 274 °C
Mold temperature	30 - 50 °C
Molding pressure range	82,5 - 103 MPa

#### Durability

Water (fresh)	Excellent
Water (salt)	Excellent
Weak acids	Excellent
Strong acids	Acceptable
Weak alkalis	Excellent
Strong alkalis	Excellent
Organic solvents	Limited use
Oxidation at 500C	Unacceptable
UV radiation (sunlight)	Fair
Flammability	Highly flammable

#### Primary production energy, CO2 and water

Embodied energy, primary production	76,1	- 83,9	MJ/kg
-------------------------------------	------	--------	-------

Sources

66.8 MJ/kg (Franklin Associates, 2008); 80.1 MJ/kg (PlasticsEurope, 2014); 80 MJ/kg (Shen and Patel, 2008); 83.3 MJ/kg (Franklin Associates, 2010); 89.8 MJ/kg (Thiriez and Gutowski, 2006)

CO2 footprint, primary production	1,77	- 1,95	kg/kg
-----------------------------------	------	--------	-------

Sources

1.8 kg/kg (PlasticsEurope, 2014); 1.92 kg/kg (Franklin Associates, 2008)

Water usage	* 55,3	- 61,1	l/kg
-------------	--------	--------	------

#### Processing energy, CO2 footprint & water

Polymer extrusion energy	* 5,9	- 6,52	MJ/kg
Polymer extrusion CO2	* 0,442	- 0,489	kg/kg
Polymer extrusion water	* 4,86	- 7,29	l/kg
Polymer molding energy	* 20,8	- 23	MJ/kg
Polymer molding CO2	* 1,56	- 1,73	kg/kg
Polymer molding water	* 13,5	- 20,2	l/kg
Coarse machining energy (per unit wt removed)	* 0,688	- 0,76	MJ/kg
Coarse machining CO2 (per unit wt removed)	* 0,0516	- 0,057	kg/kg
Fine machining energy (per unit wt removed)	* 2,6	- 2,88	MJ/kg
Fine machining CO2 (per unit wt removed)	* 0,195	- 0,216	kg/kg
Grinding energy (per unit wt removed)	* 4,73	- 5,23	MJ/kg
Grinding CO2 (per unit wt removed)	* 0,355	- 0,392	kg/kg

#### Recycling and end of life

Recycle	✓
---------	---

Values marked \* are estimates.  
No warranty is given for the accuracy of this data



Embodied energy, recycling	* 25,4	- 28,1	MJ/kg
CO2 footprint, recycling	* 0,898	- 0,993	kg/kg
Recycle fraction in current supply	8,02	- 8,86	%
Downcycle	✓		
Combust for energy recovery	✓		
Heat of combustion (net)	* 44	- 46,2	MJ/kg
Combustion CO2	* 3,06	- 3,22	kg/kg
Landfill	✓		
Biodegrade	✗		

#### Links

ProcessUniverse  
Producers  
Reference  
Shape

Values marked \* are estimates.  
No warranty is given for the accuracy of this data

#### General information

##### Designation

Poly Vinyl Chloride (Rigid, Molding); Type I

##### Tradenames

Alpha, Apex, Aurora, Axiall, Boltaron, Colorite, Dugdale, Dural, Evicom, Fainplast, Formolon, Geon, Geon Cellular, Geon Duracap, Geon Fittings, Geon Suspension, Hanwha, Hoffman, Hy-Vin, Iztavil, K-Bin, Oxyvinyls, Prime, Reinier, Reon, Self-Frosting, Sinvicomp, Solvin, Suprel, Sylvin, Unichem, Vestolit, Vi-Chem, Vinika, Vinnolit, Weatherflex

##### Typical uses

Pipe and pipe fittings, building products, bottles, film, records, floor tiling.

#### Composition overview

##### Compositional summary

Compound of PVC, (CH<sub>2</sub>CHCl)<sub>n</sub>, with stabilizer (commonly tin-based)

Material family	Plastic (thermoplastic, amorphous)
Base material	PVC (Polyvinyl chloride, rigid, unplasticized)
Polymer code	PVC

##### Composition detail (polymers and natural materials)

Polymer	100	%
---------	-----	---

##### Price

Price	* 1,52	- 1,57	EUR/kg
Price per unit volume	* 1,98e3	- 2,34e3	EUR/m <sup>3</sup>

##### Physical properties

Density	1,3e3	- 1,49e3	kg/m <sup>3</sup>
---------	-------	----------	-------------------

##### Mechanical properties

Young's modulus	2,48	- 3,3	GPa
Specific stiffness	1,76	- 2,4	MN.m/kg
Yield strength (elastic limit)	41,4	- 52,7	MPa
Tensile strength	41,4	- 52,7	MPa
Specific strength	29,3	- 38,5	kN.m/kg
Elongation	40	- 80	% strain
Compressive modulus	* 2,41	- 3,3	GPa
Compressive strength	* 37	- 44,3	MPa
Flexural modulus	2,7	- 3,4	GPa
Flexural strength (modulus of rupture)	83	- 92	MPa
Shear modulus	* 0,883	- 1,18	GPa
Poisson's ratio	* 0,395	- 0,405	
Shape factor	6		
Hardness - Vickers	* 12	- 16	HV
Hardness - Rockwell M	* 72	- 90	
Hardness - Rockwell R	105	- 130	
Hardness - Shore D	80	- 85	
Elastic stored energy (springs)	294	- 495	kJ/m <sup>3</sup>

Values marked \* are estimates.  
No warranty is given for the accuracy of this data

Fatigue strength at 10 <sup>7</sup> cycles	* 16,6	- 21,1	MPa
--	--------	--------	-----

### Impact & fracture properties

Fracture toughness	* 3,63	- 3,85	MPa.m <sup>0.5</sup>
Toughness (G)	4,19	- 5,69	kJ/m <sup>2</sup>
Impact strength, notched 23 °C	3,8	- 5,4	kJ/m <sup>2</sup>
Impact strength, notched -30 °C	* 1	- 2	kJ/m <sup>2</sup>
Impact strength, unnotched 23 °C	590	- 600	kJ/m <sup>2</sup>

### Thermal properties

Glass temperature	80	- 88	°C
Heat deflection temperature 0.45MPa	68	- 76	°C
Heat deflection temperature 1.8MPa	65	- 73	°C
Vicat softening point	* 68	- 76	°C
Maximum service temperature	50	- 65	°C
Minimum service temperature	-10	- 0	°C
Thermal conductivity	0,147	- 0,209	W/m.°C
Specific heat capacity	1e3	- 1,1e3	J/kg.°C
Thermal expansion coefficient	90	- 180	µstrain/°C
Thermal shock resistance	87,9	- 187	°C
Thermal distortion resistance	* 9,45e-4	- 0,00201	MW/m

### Electrical properties

Electrical resistivity	1e20	- 1e22	µohm.cm
Electrical conductivity	1,72e-20	- 1,72e-18	%IACS
Dielectric constant (relative permittivity)	3	- 3,2	
Dissipation factor (dielectric loss tangent)	0,02	- 0,03	
Dielectric strength (dielectric breakdown)	13,8	- 19,7	MV/m
Comparative tracking index	400	- 600	V

### Magnetic properties

Magnetic type	Non-magnetic
---------------	--------------

### Optical, aesthetic and acoustic properties

Refractive index	1,53	- 1,54	
Transparency	Transparent		
Acoustic velocity	1,32e3	- 1,55e3	m/s
Mechanical loss coefficient (tan delta)	* 0,00966	- 0,0166	

### Critical materials risk

Contains >5wt% critical elements?	No
-----------------------------------	----

### Absorption & permeability

Water absorption @ 24 hrs	0,04	- 0,4	%
Water vapor transmission	0,836	- 0,924	g.mm/m <sup>2</sup> .day
Permeability (O2)	3,49	- 6,96	cm <sup>3</sup> .mm/m <sup>2</sup> .day.atm

### Processing properties

Polymer injection molding	Acceptable
---------------------------	------------

Values marked \* are estimates.  
No warranty is given for the accuracy of this data

Polymer extrusion	Excellent
Polymer thermoforming	Excellent
Linear mold shrinkage	0,2 - 0,6 %
Melt temperature	177 - 199 °C
Mold temperature	20 - 40 °C
Molding pressure range	68,8 - 275 MPa

### Durability

Water (fresh)	Excellent
Water (salt)	Excellent
Weak acids	Excellent
Strong acids	Excellent
Weak alkalis	Excellent
Strong alkalis	Excellent
Organic solvents	Limited use
Oxidation at 500C	Unacceptable
UV radiation (sunlight)	Fair
Flammability	Self-extinguishing

### Primary production energy, CO2 and water

Embodied energy, primary production	53,7	- 59,2	MJ/kg
-------------------------------------	------	--------	-------

Sources

50.8 MJ/kg (Franklin Associates, 2008); 50.9 MJ/kg (Franklin Associates, 2008); 52.4 MJ/kg (Song, Youn, Gutowski, 2009); 53 MJ/kg (Song, Youn, Gutowski, 2009); 53.2 MJ/kg (Patel, 2003); 60.6 MJ/kg (PlasticsEurope, 2016); 57.2 MJ/kg (Potting and Blok, 1996); 59.2 MJ/kg (Thiriez and Gutowski, 2006); 70.8 MJ/kg (PlasticsEurope, 2016); 92.6 MJ/kg (Stripple, Westman, Holm, 2008)

CO2 footprint, primary production	2,13	- 2,34	kg/kg
-----------------------------------	------	--------	-------

Sources

1.99 kg/kg (PlasticsEurope, 2016); 2.16 kg/kg (Kemna et al. 2005); 2.56 kg/kg (PlasticsEurope, 2016)

Water usage	* 197	- 218	l/kg
-------------	-------	-------	------

### Processing energy, CO2 footprint & water

Polymer extrusion energy	* 5,65	- 6,25	MJ/kg
Polymer extrusion CO2	* 0,424	- 0,469	kg/kg
Polymer extrusion water	* 4,76	- 7,14	l/kg
Polymer molding energy	* 14	- 15,4	MJ/kg
Polymer molding CO2	* 1,05	- 1,16	kg/kg
Polymer molding water	* 10,6	- 15,9	l/kg
Coarse machining energy (per unit wt removed)	* 0,751	- 0,83	MJ/kg
Coarse machining CO2 (per unit wt removed)	* 0,0564	- 0,0623	kg/kg
Fine machining energy (per unit wt removed)	* 3,24	- 3,58	MJ/kg
Fine machining CO2 (per unit wt removed)	* 0,243	- 0,268	kg/kg
Grinding energy (per unit wt removed)	* 6	- 6,63	MJ/kg
Grinding CO2 (per unit wt removed)	* 0,45	- 0,498	kg/kg

### Recycling and end of life

Recycle	✓
Embodied energy, recycling	* 19,4 - 21,5 MJ/kg
CO2 footprint, recycling	* 0,947 - 1,05 kg/kg
Recycle fraction in current supply	1,43 - 1,58 %
Downcycle	✓

Values marked \* are estimates.  
No warranty is given for the accuracy of this data



Combust for energy recovery	✓			
Heat of combustion (net)	* 17,5	- 18,4	MJ/kg	
Combustion CO2	* 1,37	- 1,44	kg/kg	
Landfill	✓			
Biodegrade	✗			

**Links**

ProcessUniverse
Producers
Reference
Shape

Values marked \* are estimates.  
No warranty is given for the accuracy of this data

# 12.0 APPENDIX C



## Project

First Saved	Sunday, May 26, 2019
Last Saved	Sunday, May 26, 2019
Product Version	19.1 Release
Save Project Before Solution	No
Save Project After Solution	No

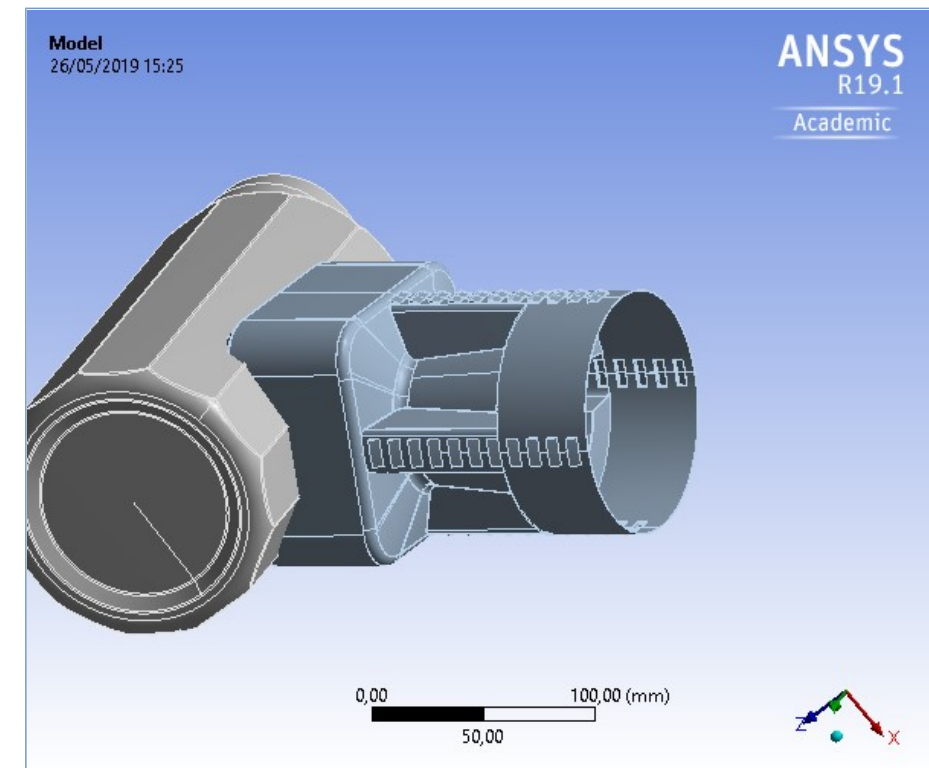

## Contents

- [Units](#)
- [Model \(A4\)](#)
  - [Geometry](#)
    - [Parts](#)
  - [Materials](#)
    - [Structural Steel](#)
    - [Polyethylene](#)
  - [Coordinate Systems](#)
  - [Connections](#)
    - [Contacts](#)
      - [Contact Region](#)
  - [Mesh](#)
  - [Static Structural \(A5\)](#)
    - [Analysis Settings](#)
    - [Loads](#)
    - [Solution \(A6\)](#)
      - [Solution Information](#)
      - [Results](#)
- [Material Data](#)
  - [Polyethylene](#)

## Units

TABLE 1

Unit System	Metric (mm, kg, N, s, mV, mA) Degrees rad/s Celsius
Angle	Degrees
Rotational Velocity	rad/s
Temperature	Celsius

## Model (A4)

### Geometry

TABLE 2  
Model (A4) > Geometry

Object Name	Geometry
State	Fully Defined
<b>Definition</b>	
Source	C:\Users\Ginevra\Desktop\remesh.igs
Type	Iges
Length Unit	Millimeters
Element Control	Program Controlled
Display Style	Body Color
<b>Bounding Box</b>	
Length X	254,24 mm
Length Y	283,03 mm
Length Z	295,32 mm
<b>Properties</b>	
Volume	1,6794e+005 mm <sup>3</sup>

Mass	0,15954 kg
Scale Factor Value	1,
<b>Statistics</b>	
Bodies	4
Active Bodies	2
Nodes	64941
Elements	32805
Mesh Metric	None
<b>Update Options</b>	
Assign Default Material	No
<b>Basic Geometry Options</b>	
Solid Bodies	Yes
Surface Bodies	Yes
Line Bodies	No
Parameters	Independent
Parameter Key	ANS;DS
Attributes	No
Named Selections	No
Material Properties	No
<b>Advanced Geometry Options</b>	
Use Associativity	Yes
Coordinate Systems	No
Reader Mode Saves Updated File	No
Use Instances	Yes
Smart CAD Update	Yes
Compare Parts On Update	No
Analysis Type	3-D
Mixed Import Resolution	None
Decompose Disjoint Geometry	Yes
Enclosure and Symmetry Processing	Yes

TABLE 3  
Model (A4) > Geometry > Parts

Object Name	remesh-FreeParts	remesh-FreeParts [2]	remesh-FreeParts [3]	remesh-FreeParts [4]
State	Meshed			Suppressed
<b>Graphics Properties</b>				
Visible	Yes			No
Transparency	1			
<b>Definition</b>				
Suppressed	No			Yes
Stiffness Behavior	Flexible			
Coordinate System	Default Coordinate System			
Reference Temperature	By Environment			
Behavior	None			
<b>Material</b>				
Assignment	Polyethylene			
Nonlinear Effects	Yes			
Thermal Strain Effects	Yes			
<b>Bounding Box</b>				
Length X	166,14 mm	197,86 mm	0,53711 mm	0,84863 mm
Length Y	283,03 mm	146,47 mm	1,0464 mm	0,92285 mm
Length Z	158,73 mm	224,64 mm	0,43652 mm	6,5186e-002 mm
<b>Properties</b>				
Volume	1,2691e+005 mm <sup>3</sup>	41035 mm <sup>3</sup>		



Mass	0,12056 kg	3,8983e-002 kg		
Centroid X	-11203 mm	-11142 mm	-11120 mm	-11172 mm
Centroid Y	-7017,8 mm	-6982,1 mm	-7020,6 mm	-6942,6 mm
Centroid Z	1182,1 mm	1087,3 mm	1098, mm	1084,9 mm
Moment of Inertia Ip1	1100,1 kg·mm <sup>2</sup>	178,59 kg·mm <sup>2</sup>	0, kg·mm <sup>2</sup>	
Moment of Inertia Ip2	416,73 kg·mm <sup>2</sup>	178,72 kg·mm <sup>2</sup>	0, kg·mm <sup>2</sup>	
Moment of Inertia Ip3	1107,5 kg·mm <sup>2</sup>	113,01 kg·mm <sup>2</sup>	0, kg·mm <sup>2</sup>	
<b>Statistics</b>				
Nodes	24246	40695	0	
Elements	12266	20539	0	
Mesh Metric	None			

### Coordinate Systems

**TABLE 4**  
Model (A4) > Coordinate Systems > Coordinate System

Object Name	Global Coordinate System
State	Fully Defined
<b>Definition</b>	
Type	Cartesian
Coordinate System ID	0,
<b>Origin</b>	
Origin X	0, mm
Origin Y	0, mm
Origin Z	0, mm
<b>Directional Vectors</b>	
X Axis Data	[ 1, 0, 0, ]
Y Axis Data	[ 0, 1, 0, ]
Z Axis Data	[ 0, 0, 1, ]

### Connections

**TABLE 5**  
Model (A4) > Connections

Object Name	Connections
State	Fully Defined
<b>Auto Detection</b>	
Generate Automatic Connection On Refresh	Yes
<b>Transparency</b>	
Enabled	Yes

**TABLE 6**  
Model (A4) > Connections > Contacts

Object Name	Contacts
State	Fully Defined
<b>Definition</b>	
Connection Type	Contact
<b>Scope</b>	
Scoping Method	Geometry Selection
Geometry	All Bodies
<b>Auto Detection</b>	
Tolerance Type	Slider
Tolerance Slider	0,
Tolerance Value	1,204 mm
Use Range	No
Face/Face	Yes

Face Overlap Tolerance	Off
Cylindrical Faces	Include
Face/Edge	No
Edge/Edge	No
Priority	Include All
Group By	Bodies
Search Across	Bodies
<b>Statistics</b>	
Connections	1
Active Connections	1

**TABLE 7**  
Model (A4) > Connections > Contacts > Contact Regions

Object Name	Contact Region
State	Fully Defined
<b>Scope</b>	
Scoping Method	Geometry Selection
Contact	6 Faces
Target	7 Faces
Contact Bodies	remesh-FreeParts
Target Bodies	remesh-FreeParts[2]
Protected	No
<b>Definition</b>	
Type	Bonded
Scope Mode	Automatic
Behavior	Program Controlled
Trim Contact	Program Controlled
Trim Tolerance	1,204 mm
Suppressed	No
<b>Advanced</b>	
Formulation	Program Controlled
Small Sliding	Program Controlled
Detection Method	Program Controlled
Penetration Tolerance	Program Controlled
Elastic Slip Tolerance	Program Controlled
Normal Stiffness	Program Controlled
Update Stiffness	Program Controlled
Pinball Region	Program Controlled
<b>Geometric Modification</b>	
Contact Geometry Correction	None
Target Geometry Correction	None

### Mesh

**TABLE 8**  
Model (A4) > Mesh

Object Name	Mesh
State	Solved
<b>Display</b>	
Display Style	Body Color
<b>Defaults</b>	
Physics Preference	Mechanical
Element Order	Program Controlled
Element Size	Default
<b>Sizing</b>	
Use Adaptive Sizing	Yes

Resolution	Default (2)
Mesh Defeaturing	Yes
Defeature Size	Default
Transition	Fast
Span Angle Center	Coarse
Initial Size Seed	Assembly
Bounding Box Diagonal	481,62 mm
Average Surface Area	324,15 mm <sup>2</sup>
Minimum Edge Length	1,1877e-005 mm
<b>Quality</b>	
Check Mesh Quality	Yes, Errors
Error Limits	Standard Mechanical
Target Quality	Default (0.050000)
Smoothing	Medium
Mesh Metric	None
<b>Inflation</b>	
Use Automatic Inflation	None
Inflation Option	Smooth Transition
Transition Ratio	0,272
Maximum Layers	5
Growth Rate	1,2
Inflation Algorithm	Pre
View Advanced Options	No
<b>Advanced</b>	
Number of CPUs for Parallel Part Meshing	Program Controlled
Straight Sided Elements	No
Number of Retries	Default (4)
Rigid Body Behavior	Dimensionally Reduced
Triangle Surface Mesher	Program Controlled
Topology Checking	Yes
Pinch Tolerance	Please Define
Generate Pinch on Refresh	No
<b>Statistics</b>	
Nodes	64941
Elements	32805

**Static Structural (A5)**

**TABLE 9**  
Model (A4) > Analysis

Object Name	Static Structural (A5)
State	Solved
<b>Definition</b>	
Physics Type	Structural
Analysis Type	Static Structural
Solver Target	Mechanical APDL
<b>Options</b>	
Environment Temperature	22, °C
Generate Input Only	No

**TABLE 10**  
Model (A4) > Static Structural (A5) > Analysis Settings

Object Name	Analysis Settings
State	Fully Defined
<b>Step Controls</b>	
Number Of Steps	1,

Current Step Number	1,
Step End Time	1, s
Auto Time Stepping	Program Controlled
<b>Solver Controls</b>	
Solver Type	Program Controlled
Weak Springs	Off
Solver Pivot Checking	Program Controlled
Large Deflection	Off
Inertia Relief	Off
<b>Rotordynamics Controls</b>	
Coriolis Effect	Off
<b>Restart Controls</b>	
Generate Restart Points	Program Controlled
Retain Files After Full Solve	No
Combine Restart Files	Program Controlled
<b>Nonlinear Controls</b>	
Newton-Raphson Option	Program Controlled
Force Convergence	Program Controlled
Moment Convergence	Program Controlled
Displacement Convergence	Program Controlled
Rotation Convergence	Program Controlled
Line Search	Program Controlled
Stabilization	Off
<b>Output Controls</b>	
Stress	Yes
Strain	Yes
Nodal Forces	No
Contact Miscellaneous	No
General Miscellaneous	No
Store Results At	All Time Points
<b>Analysis Data Management</b>	
Solver Files Directory	C:\Users\Ginevra\Desktop\structural test FINAL!_files\dp0\SYS\MECH\
Future Analysis	None
Scratch Solver Files Directory	
Save MAPDL db	No
Contact Summary	Program Controlled
Delete Unneeded Files	Yes
Nonlinear Solution	No
Solver Units	Active System
Solver Unit System	nmm

**TABLE 11**  
Model (A4) > Static Structural (A5) > Loads

Object Name	Fixed Support	Force
State	Fully Defined	
<b>Scope</b>		
Scoping Method	Geometry Selection	
Geometry	3 Faces	1 Face
<b>Definition</b>		
Type	Fixed Support	Force
Suppressed	No	
Define By	Vector	
Magnitude	100, N (ramped)	
Direction	Defined	

**FIGURE 1**  
Model (A4) > Static Structural (A5) > Force



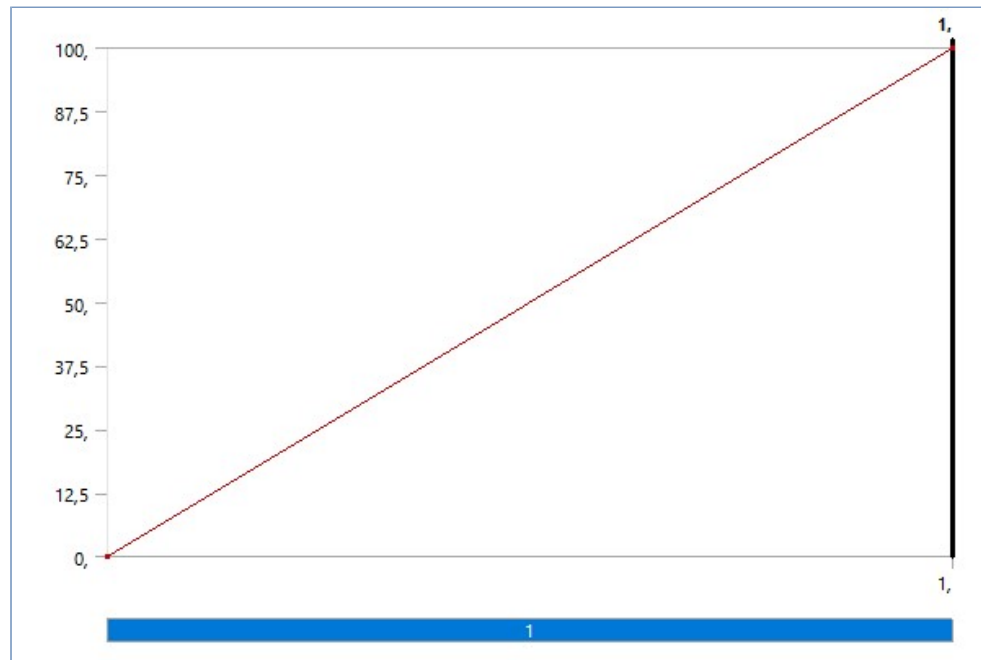

Solution (A6)

**TABLE 12**  
Model (A4) > Static Structural (A5) > Solution

Object Name	Solution (A6)
State	Solved
<b>Adaptive Mesh Refinement</b>	
Max Refinement Loops	1,
Refinement Depth	2,
<b>Information</b>	
Status	Done
MAPDL Elapsed Time	13, s
MAPDL Memory Used	763, MB
MAPDL Result File Size	26,625 MB
<b>Post Processing</b>	
Beam Section Results	No
On Demand Stress/Strain	No

**TABLE 13**  
Model (A4) > Static Structural (A5) > Solution (A6) > Solution Information

Object Name	Solution Information
State	Solved
<b>Solution Information</b>	
Solution Output	Solver Output
Newton-Raphson Residuals	0
Identify Element Violations	0
Update Interval	2,5 s
Display Points	All
<b>FE Connection Visibility</b>	
Activate Visibility	Yes
Display	All FE Connectors
Draw Connections Attached To	All Nodes

Line Color	Connection Type
Visible on Results	No
Line Thickness	Single
Display Type	Lines

**TABLE 14**  
Model (A4) > Static Structural (A5) > Solution (A6) > Results

Object Name	Total Deformation	Equivalent Elastic Strain	Equivalent Stress
State	Solved		
<b>Scope</b>			
Scoping Method	Geometry Selection		
Geometry	All Bodies		
<b>Definition</b>			
Type	Total Deformation	Equivalent Elastic Strain	Equivalent (von-Mises) Stress
By	Time		
Display Time	Last		
Calculate Time History	Yes		
Identifier			
Suppressed	No		
<b>Results</b>			
Minimum	0, mm	9,7221e-011 mm/mm	4,6363e-008 MPa
Maximum	21,112 mm	0,13076 mm/mm	126,86 MPa
Average	5,7141 mm	4,6053e-003 mm/mm	3,4079 MPa
Minimum Occurs On	remesh-FreeParts		
Maximum Occurs On	remesh-FreeParts[2]		
<b>Information</b>			
Time	1, s		
Load Step	1		
Substep	1		
Iteration Number	1		
<b>Integration Point Results</b>			
Display Option	Averaged		
Average Across Bodies	No		

**FIGURE 2**  
Model (A4) > Static Structural (A5) > Solution (A6) > Total Deformation

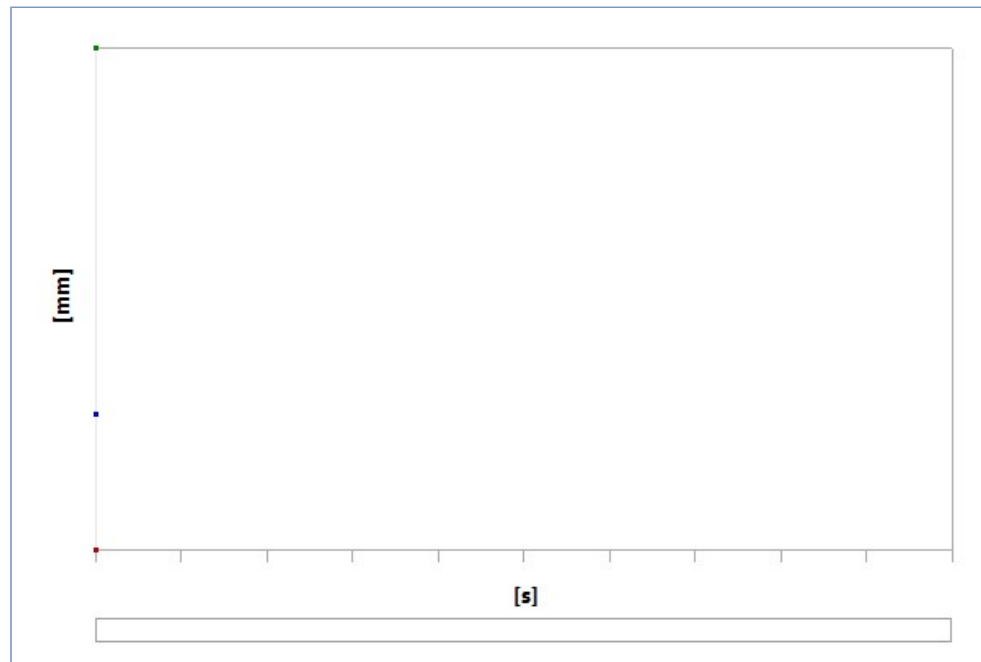

**TABLE 15**  
Model (A4) > Static Structural (A5) > Solution (A6) > Total Deformation

Time [s]	Minimum [mm]	Maximum [mm]	Average [mm]
1,	0,	21,112	5,7141

**FIGURE 3**  
Model (A4) > Static Structural (A5) > Solution (A6) > Equivalent Elastic Strain

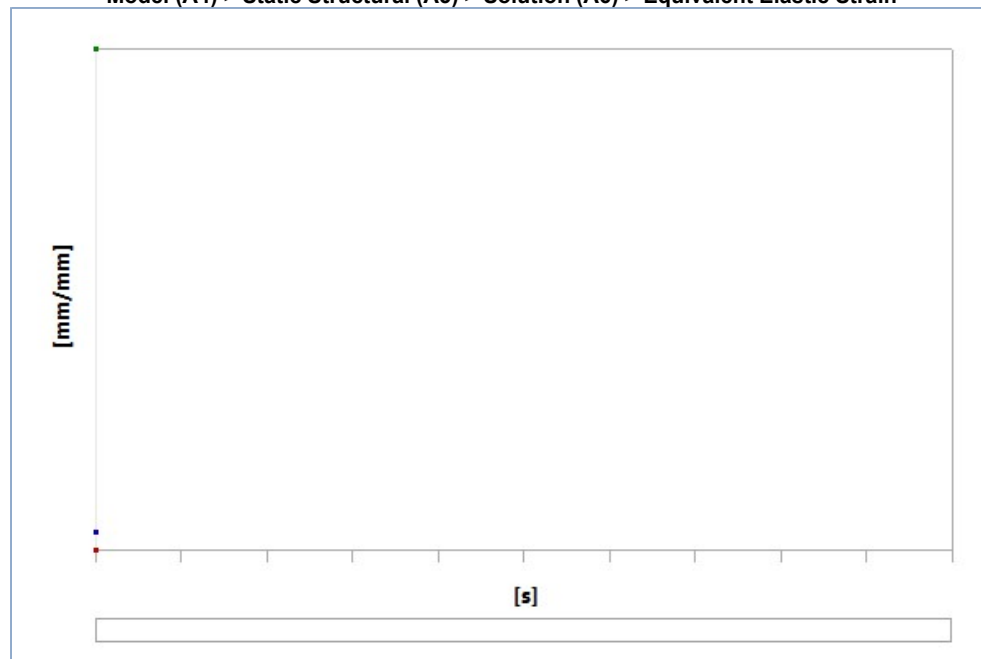

**TABLE 16**

**Model (A4) > Static Structural (A5) > Solution (A6) > Equivalent Elastic Strain**

Time [s]	Minimum [mm/mm]	Maximum [mm/mm]	Average [mm/mm]
1,	9,7221e-011	0,13076	4,6053e-003

**FIGURE 4**

**Model (A4) > Static Structural (A5) > Solution (A6) > Equivalent Stress**

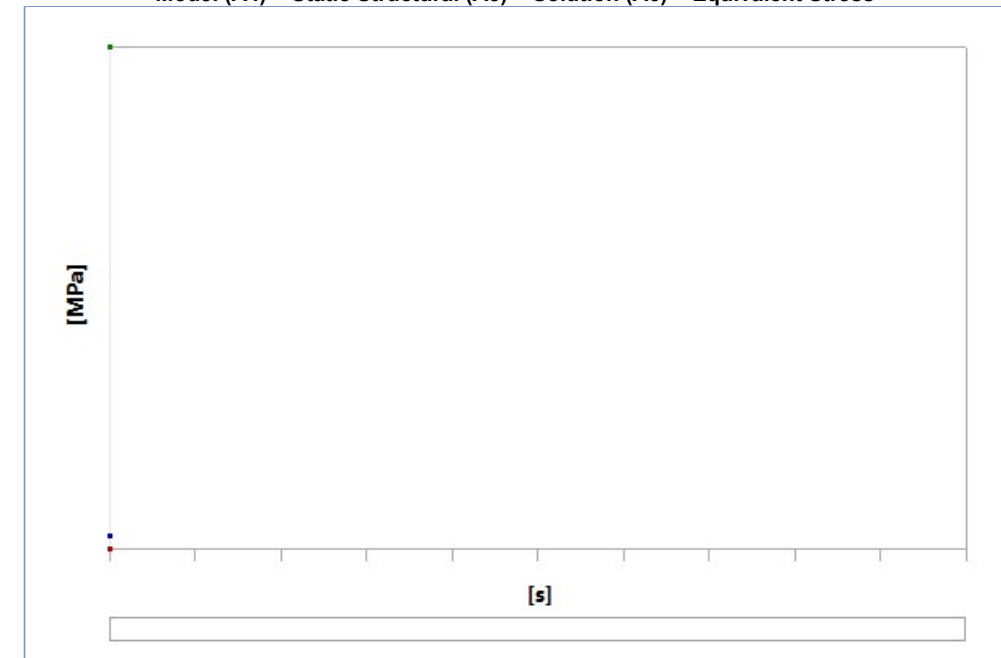

**TABLE 17**

**Model (A4) > Static Structural (A5) > Solution (A6) > Equivalent Stress**

Time [s]	Minimum [MPa]	Maximum [MPa]	Average [MPa]
1,	4,6363e-008	126,86	3,4079

## Material Data

### Polyethylene

**TABLE 18**  
Polyethylene > Constants

Density	9,5e-007 kg mm <sup>-3</sup>
Isotropic Secant Coefficient of Thermal Expansion	2,3e-004 C <sup>-1</sup>
Specific Heat Constant Pressure	2,3e+006 mJ kg <sup>-1</sup> C <sup>-1</sup>
Isotropic Thermal Conductivity	2,8e-004 W mm <sup>-1</sup> C <sup>-1</sup>

**TABLE 19**  
Polyethylene > Color

Red	Green	Blue
130,	154,	176,

**TABLE 20**  
Polyethylene > Compressive Ultimate Strength

Compressive Ultimate Strength MPa	0,
-----------------------------------	----



**TABLE 21**  
**Polyethylene > Compressive Yield Strength**

Compressive Yield Strength MPa
0,

**TABLE 22**  
**Polyethylene > Tensile Yield Strength**

Tensile Yield Strength MPa
25,

**TABLE 23**  
**Polyethylene > Tensile Ultimate Strength**

Tensile Ultimate Strength MPa
33,

**TABLE 24**  
**Polyethylene > Isotropic Secant Coefficient of Thermal Expansion**

Zero-Thermal-Strain Reference Temperature C
22,

**TABLE 25**  
**Polyethylene > Isotropic Elasticity**

Young's Modulus MPa	Poisson's Ratio	Bulk Modulus MPa	Shear Modulus MPa	Temperature C
1100,	0,42	2291,7	387,32	

