

# Albertian Grammatical Transformations

## *From the treatise to the built work in the design of sacred buildings*

Bruno Figueiredo<sup>1</sup>, José Pinto Duarte<sup>2</sup>, Mário Krüger<sup>3</sup>

<sup>1</sup>School of Architecture, University of Minho, Portugal, <sup>2</sup>CIAUD, Faculdade de Arquitectura, Universidade Técnica de Lisboa, Portugal, <sup>3</sup>Department of Architecture, Centre for Social Studies, University of Coimbra, Portugal

<sup>1</sup><http://www.arquitectura.uminho.pt/3751.page-pt>, <sup>2</sup><http://home.fa.utl.pt/~jduarte/> <sup>3</sup><http://woc.uc.pt/darq/person/ppgeral.do?idpessoa=1>

<sup>1</sup>[bfigueiredo@arquitectura.uminho.pt](mailto:bfigueiredo@arquitectura.uminho.pt), <sup>2</sup>[jduarte@fa.utl.pt](mailto:jduarte@fa.utl.pt), <sup>3</sup>[kruger@ci.uc.pt](mailto:kruger@ci.uc.pt)

**Abstract.** *This paper presents a research on the use of shape grammars as an analytical tool in the history of architecture. It evolves within a broader project called Digital Alberti, whose goal is to determine the influence of De re aedificatoria treatise on Portuguese Renaissance architecture, making use of a computational framework (Krüger et al., 2011).*

*Previous work was concerned with the development of a shape grammar for generating sacred buildings according to the rules textually described in the treatise. This work describes the transformation of the treatise grammar into another grammar that can also account for the generation of Alberti's built work.*

**Keywords.** *Shape grammars; parametric modelling; generative design; Alberti; classical architecture.*

## INTRODUCTION

The research described in this paper is part of a larger project called Digital Alberti, whose aim is to determine the influence of Alberti's treatise *De re aedificatoria* on Portuguese Renaissance architecture, making use of a computational framework (Krüger et al., 2011).

This paper analysis the task of achieving a shape grammar that can contribute for clarifying the influence of Alberti's work on Portuguese architecture of the counter-reform period. Previous work was concerned with the translation of *De re aedificatoria's* descriptions of sacred buildings into a generative shape grammar. (Duarte et al., 2011; Figueiredo et al., 2013) This grammar has shown to be successful

in deriving solutions in the same language. However, certain features of Portuguese classical churches are not identifiable in such solutions and, therefore, its source of inspiration remains uncertain.

Several scholars in the history of Portuguese Renaissance architecture report that Portuguese royal house contracted Italian architects and promoted the visit of Portuguese architects to Italy during the 15th and 16th century. (Moreira 1991, 1995; Soromenho, 1995; Branco, 2008) This fact may have caused architects who worked in Portugal during that period to contact with Alberti's buildings that were erected in the late 15th century.

This fact led us to consider the transformation

of the shape grammar (Knight, 1983) for generating sacred buildings according to the rules textually described in the treatise, into another grammar that could account for the generation of his built work, namely, its morphological and proportional features.

This paper presents the methodology used to transform the initial treatise grammar into a grammar that can unveil the origin of certain features of Portuguese Renaissance architecture.

## METHODOLOGY

A previous grammar, directly inferred from the reading of *De re aedificatoria*, was considered for this research (Duarte et al., 2011). Their rules are mainly described on Chapters IV and V of Book 7 – *Ornament to Sacred Buildings*, where the treatise expresses in algorithmic terms the knowledge base for the design of sacred buildings – temples.

In accordance with the objectives described in the introduction above, the approach followed in this research included four steps: (1) to analyze the most representative sacred buildings by Alberti, with the aim of identifying morphological and proportional features that were not encoded by the treatise grammar; and subsequently synthesizing that information in parametric schemas; (2) to introduce the knowledge encoded by the parametric schemas in the grammar, by changing existing rules or adding new ones; (3) to determine the relation among these rules, the grammar's recursive structure, and the process of derivation solutions in the language; and (4) to translate the grammar's principles into a parametric computational model that allowed one to evaluate the generative outcome of the grammar in a different generative paradigm.

## FROM ALBERTI BUILDINGS TO GRAMMAR TRANSFORMATION

The first task in this research was focused on the analysis of Alberti's designs of sacred buildings. Namely, the church of Sant'Andrea in Mantua, rebuilt according to Alberti's 1470 design for Ludovico Gonzaga; the church of San Sebastiano in Mantua,

designed in a Greek cross plan, in consonance with Antonio Labacco drawings (Tavernor, 1996, p.128), to which Alberti planned the construction of a dome in the central space, instead of the existing coved vaults; the external walls of the church of San Francesco, known as the Temple Malatestiano in Rimini, begun in 1453, unfinished, and mainly rebuilt after being severely damaged during World War II; and finally, the facade of Santa Maria Novella in Florence (1458–70) which resulted from a commission of the Rucellai family.

The sources of the drawings used in this task were the photogrammetric surveys done by the Olivetti Group [1] for the exhibition held in Palazzo Te, Mantua in 1994. These drawings were chosen because they do not include later modifications in the buildings layout and architectural details, which can then be considered more loyal to Alberti's design intentions. The first step in accomplishing this task was to collect data identifying Alberti's contributions for the design of each of the buildings (Borsi, 1989; Tavernor, 1998; Rykwert and Angel, 1994).

Following to this, drawings of the buildings were analyzed with the aim of identifying morphological and proportional features that have not been considered in the treatise grammar. Two complementary analysis were performed.

The first analysis was to fill in a survey in which entries collect the buildings' features taking in account the parts of sacred buildings described in the treatise grammar. This information was registered on tables gathering the parameters, conditions and spatial relations translated from both the treatise and the buildings thereby allowing to identify similarities and deviances between them.

The second analysis was to draw schemas that were useful for synthesizing the buildings' proportional principles, and to identify morphological features that were absent in the treatise's descriptions.

Due to the space restrictions, this article focuses on the analysis of Sant'Andrea's plan. The result of this analysis is synthesized in the Table 1, which synthesizes a survey comparing Sant'Andrea's features with those described in the treatise and in

Table 1

Excerpt from a table summarizing the analysis of the morphological features and proportions of Sant'Andrea's plan. Green rectangles mean that the feature is contemplated in the grammar, while red rectangles mean that it is new to the grammar.

| PLAN  |                    |          |                       |         |      |
|---|--------------------|----------|-----------------------|---------|------|
| Cell Proportion ( $Li : Wi$ )<br><i>li</i> - area length<br><i>wi</i> - area width                | .1:1               | .3:2     | .4:3                  | .2:1    | .3:1 |
| Tribune   | True               | False    |                       |         |      |
| Opening ( $Wc : Wi$ )<br><i>wi</i> - area width<br><i>wc</i> - chapel width                       | .1:2               | .2:3     |                       |         |      |
| Geometry/Shape  | REC                | CIR      |                       |         |      |
| Proportion ( $Lc : Wc$ )<br><i>lc</i> - chapel length<br><i>wc</i> - chapel width                 | .1:1               | .1:2     |                       |         |      |
| Lateral Chapels   | True               | False    |                       |         |      |
| Number $Ncl$  | 2                  | 6        | 10                    |         |      |
| Geometry/Shape  | REC                | CIR      | REC/CIR               | CIR/REC |      |
| Opening/Width ( $Wc : Wcl$ )  | .1:1               | .1:11/12 |                       |         |      |
|   | falta informa      |          |                       |         |      |
| Length ( $Lcl : Wcl$ )<br><i>Lcl</i> - lateral chapel length<br><i>Wcl</i> - lateral chapel width | .1:1               | .1:2     |                       |         |      |
| Skeleton ( $Wcl : Ws$ )   | (1:1/5 , 1: 1/3)   | 1 : 1/2  | $\sqrt{3} : \sqrt{2}$ |         |      |
| Wall Thickness ( $We : Tw$ )<br><i>we</i> - temple width (external)<br><i>tw</i> - wall thickness | .1:12              | .1:9     | .1:28                 |         |      |
|   | <i>sem capelas</i> |          | <i>com capelas</i>    |         |      |

Figure 1, which diagrams Sant'Andrea's plan proportional schema. Both analyses revealed three main aspects that differentiate Sant'Andrea's plan from the treatise grammar generative outcome: (1) cell proportions; (2) the relative proportions between the lateral chapels' openings and the skeleton between them; (3) the rooms that fill space between lateral chapels. Both the analysis and the subsequent shape rules implications are described below.

### (1) cell proportions

In Book 7, Chapter IV, paragraph two, Alberti describes the principles for defining the proportion of cells in rectangular temples. The rule of the treatise grammar considered these proportions, where cell

length ( $Li$ ) is directly dependent of cell width ( $Wi$ ):  
 $Li = \alpha Wi ; \alpha \in \{1, 1 \frac{1}{3}, 1 \frac{1}{2}, 2\}$ .

Sant'Andrea's  $Li$  dimension corresponds to  $3Wi$ , resulting in a 3:1 proportion. Although this proportion does not comply with the descriptions in Book 7, it is foreseen in the proportions described by Alberti in Chapters V and VI of Book 9 - *Ornament on Private Buildings*: "...The method of defining the outline is best taken from those objects in which Nature offers herself to our inspection and admiration as we view and examine them. [...] The very same numbers that cause sounds to have that *concinntitas*, pleasing to the ears, can also fill the eyes and mind with wondrous delight. From musicians therefore who have already examined such numbers thor-

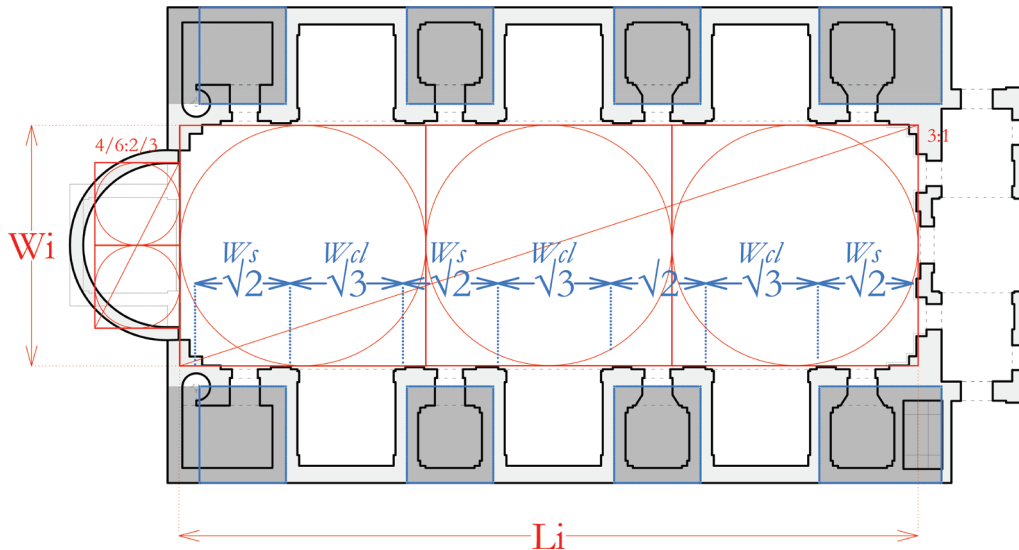

Figure 1  
Sant'Andrea's plan summarizing the analysis of cell proportions; the skeleton between lateral chapels proportions; the rooms that fill space between chapels.

oughly, or from those objects in which Nature as displayed some evident and noble quality, the whole method of outlining is derived. [...]"

On Chapter VI, Alberti refers to and describes in detail, the use of musical consonances to determine cell proportions. In synthesis, he defines that the proportions may be either short, long, or intermediate: as short proportions he considers *Square* (1:1), *Sesquialtera* (3:2) and *Sesquitertia* (4:3); as intermediate proportions *Double* (1:2), *Duplicate Sesquialtera* (9:4) and *Duplicate Sesquitertia* (16:9); and finally, as long proportions *Triple* (3:1), *Double Sesquitertia* (8:3) and *Quadruplus* (4:1).

In the same chapter, Alberti describes that *concinntas* is reached by the use of musical consonances, but he also considers the use of *correspondentiae inatae* to establish "certain natural relationships that cannot be defined as numbers, but that may be obtained through roots and powers." Further reading of this chapter enabled the inference of correspondences between certain ratios –  $(\sqrt{2}:\sqrt{1})$ ,  $(\sqrt{3}:\sqrt{2})$ ,  $(\sqrt{3}:\sqrt{1})$ ,  $(\sqrt{4}:\sqrt{3})$  – that can be used to define proportions.

By incorporating the musical consonances in the initial conditions of *Rule 1*, the grammar will able to

generate a temple with the length  $L_i$  of Sant'Andrea (Figure 2 left), and with the further integration of the *correspondentiae inatae* in set of conditions, further solutions can be achieved by the application of *Rule 1*:

$L_i = \alpha W_i$ ;  $\alpha \in \{1, 1 \frac{1}{3}, 1 \frac{1}{2}, 2, 2 \frac{1}{4}, 1 \frac{7}{9}, 3, 2 \frac{2}{3}, 4, \sqrt{2}/\sqrt{1}, \sqrt{3}/\sqrt{2}, \sqrt{3}/\sqrt{1}, \sqrt{4}/\sqrt{3}\}$ .

## (2) the proportion of the skeleton between lateral chapels

The proportional relation between lateral chapel openings ( $W_{cl}$ ) and the walls separating the various chapels ( $W_s$ ) is described on Chapter IV, Book 7, between paragraphs 4 and 7: "... the bones, that is, of the building, which separate the various openings to the tribunals in the temple - be nowhere less than a fifth of the gap, nowhere more than a third, or, where you want it particularly enclosed, no more than a half"

These parameters and conditions were synthesized in the *Rule 4* of the treatise grammar by the equation:

$$W_s = \varphi' W_{cl}; 1/5 \leq \varphi' \leq 1/3 \vee \varphi' = 1/2.$$

The  $W_s$  dimension is also dependent on cell

Figure 2

Shape rules from the rectangular temples grammar, with the included parameters and conditions: (left) Rule 1 defines cell proportions; (right) Rule 4b defines the lateral chapels' openings and places labels to design the chapel's outline using the set of Rules 5.

**R1** Initial Rule - area definition  
plan

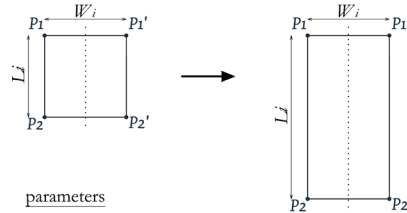

parameters

$L_i$  - area length  
 $W_i$  - area width

conditions

$L_i = \alpha W_i$

$\alpha \in \{1, 1\ 1/3, 1\ 1/2, 2, 2\ 1/4, 1\ 7/9, 3, 2\ 2/3, 4, \sqrt{2}/\sqrt{1}, \sqrt{3}/\sqrt{2}, \sqrt{3}/\sqrt{1}, \sqrt{4}/\sqrt{3}\}$

**R4b** lateral chapels opening  
plan

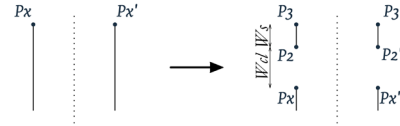

parameters

$W_c$  - chapel width  
 $W_{cl}$  - lateral chapels width  
 $W_s$  - skeleton width

conditions

$W_{cl} = \varphi W_c$ ;  $\varphi \in \{11/12, 1\}$

$W_s = \varphi' W_{cl}$

$1/5 \leq \varphi' \leq 1/3 \vee \varphi' = 1/2 \vee \varphi' \in \{\sqrt{2}/\sqrt{1}, \sqrt{3}/\sqrt{2}, \sqrt{3}/\sqrt{1}, \sqrt{4}/\sqrt{3}\}$

length  $L_i$ , which is equal to the sum of the lateral openings, plus the width  $W_s$  between them the temple's end walls, and it can be deduced by the following function:

$$W_s = (L_i - N_{cl} W_{cl}) / (N_{cl} + 1).$$

Since at Sant'Andrea, the proportion  $W_{cl}:W_s$  corresponds to  $\sqrt{3}:\sqrt{2}$  (Table 1), it does not verify the conditions specified for  $\varphi'$  in the initial rule. In a strict understanding of the principles laid out in Book VII, such a non-correspondence could have been considered as an error in the Albertian canon. However, several authors (Tavernor, 1985; Kruger, 2011) showed that the use of the proportion  $\sqrt{3}:\sqrt{2}$  to design the chapels' openings and the skeleton could be considered Albertian by introducing the use of *correspondentiae inatae* in the definition of such a proportion. The subsequently inclusion of such correspondences in the set of conditions in the original Rule 4 (Figure 2 right) results in:

$$W_s = \varphi' W_{cl}; \ 1/5 \leq \varphi' \leq 1/3 \vee \varphi' \in \{\sqrt{2}/\sqrt{1}, \sqrt{3}/\sqrt{2}, \sqrt{3}/\sqrt{1}, \sqrt{4}/\sqrt{3}\}.$$

**(3) rooms filling space between chapels, frontispiece and rear facade.**

In Sant'Andrea, the spaces in between the row of lateral chapels and the edges of the frontispiece and

rear facade form a room connected to the cell that conforms a rectangular plan (Figure 1). This spatial relation was not considered in the treatise shape grammar because it is not described in *De Re Aedificatoria*. While the addition of one single chapel per facade, as it happens in San Sebastiano, results in a relatively evident spatial relation between lateral chapels and the cell's wall, when several chapels are added to the same facade, such a spatial relation can be configured in several ways. The set of Rules 7 (Figure 3 center) show the spatial relations translated from the treatise, while Rule 7a' and Rule 7b' (Figure 3 right) show the new spatial relations introduced by reproducing the ones existent in Sant'Andrea.

**Sant'Andrea grammar add-ons**

According to Terry Knight (1983), to transform a shape grammar, at least one rule addition, rule deletion or rule change has to be performed. By taking into consideration her definition of rule change: "Rule change changes a rule, initial shape, or final state by changing any of its spatial or nonspatial components: spatial relations, spatial labels, or state labels." - the operations performed to Rule 1 and Rule 4 can be considered a rule change because they add new dimensional conditions to the initial ones.

**R6g** wall outline addition  
plan rectangular lateral chapel

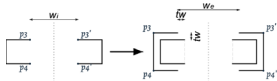

**R7** lateral chapels walls connections (rectangular)  
plan

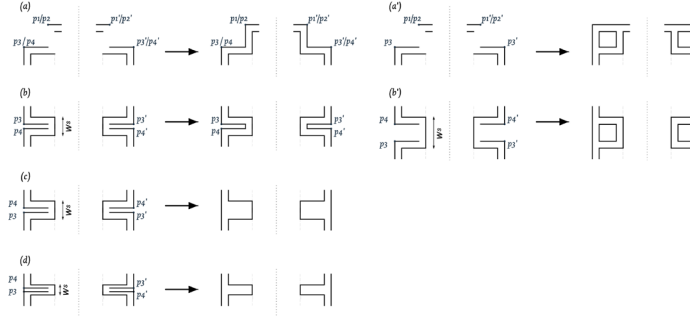

Figure 3  
Shape rules that define the addition and arrangement of walls in lateral rectangular chapels. The left rules represent the rules added to the set of Rules 7, in accordance with the spatial relation inferred from Sant'Andrea.

Despite the maintenance of the parametric schema, new spatial relations can be achieved by resizing the plan. The addition of a new rule, as in the operation described above for the addition of *Rule 7a'* and *Rule 7b'*, can also be considered a transformation of grammar.

### SHAPE GRAMMAR TRANSFORMATION WITH A CONSTANT RECURSIVE STRUCTURE

The treatise grammar followed mimetically the order of description of the temples' parts in the treatise. Their morphology is mainly described on Chapters IV and V of Book 7, in which the constituent parts of the temples are treated: cell – inner space of the temple, defined by the geometry of their area; tribune; lateral chapels and their skeletons; portico informed by the column systems – shaft, base, capital and entablature – and their proportions; pediment; walls; roof; and main openings.

While in Palladian Villas grammar (Stiny, 1978) the Villas constant partition features were useful to define the grammar recursive structure, in Alberti's built work, the few examples of designs of sacred buildings, and the typological variety of those examples do not seem to be the more appropriate for setting up a grammar representative of Alberti's sacred buildings. From the reading of the treatise, it was possible to consider a framework for the definition of the morphological parts of the temples and

their interrelations, which have been applied to define the recursive structure of the treatise grammar. Since this structure encapsulates the formal and parametric logic of Alberti's buildings, it was decided to maintain the core of their recursive structure during the transformation process. Although the recursive structure of the grammar was kept, several rules were transformed by changing their spatial relations, and other rules were added.

Figure 4 shows a step by step computation, illustrating the different options of derivation at each step, where only one derivation is subsequently transformed by the use of the next set of shape rules.

### THE CLASSIC NUMBER VERSUS THE CONTEMPORARY PARAMETRIC MODEL

#### *The 'number' in the algorithmic nature of De re aedificatoria translated by contemporary eyes*

In classical philosophy, numbers have a specific meaning before its scientific dimension. Alberti systematizes classic architectonic dimensions through considerations on the perfection of numbers, as well as establishing relationships between music harmonies and proportional systems in architecture (Book 9, V).

In Nexus 2002 conference, during a round table discussion about the significance of both the quan-

Figure 4

Computation tree of the temples shape grammar showing only one possible subsequent rule application at each step of the computation.

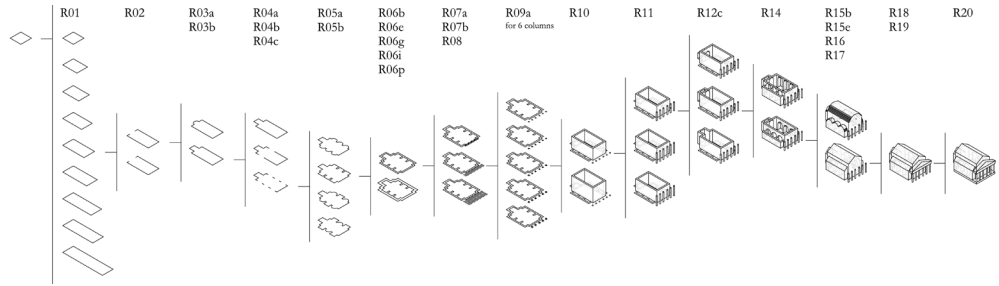

tity and the quality of numbers in *De re aedificatoria*, Lionel March in answering to Robert Tavernor's question [2] - "Can anyone explain exactly what might be meant by the "quality" of a number?" - argued for the numbers dual nature in the treatise: "When Alberti was writing, the words 'quantity' and 'quality' still retained their Aristotelian roots. (...) Thus, from an Aristotelian perspective, in giving shape to an architectural work, Alberti is engaged in qualitative decisions, but in dimensioning the work he is acting quantitatively. (...) A pediment is qualitatively 'triangular', but its dimensions are quantitatively 24 feet long to 5 feet high."

March's argument in the discussion of number significance follows to the idea that "a contemporary approach would be computational with respect to 'number' and semiotic with respect to reference and usage.

The treatise grammar inference and their subsequent transformation followed this notion of working simultaneously with a 'contemporary' understanding of 'shapes' and 'numbers'. 'Shapes' configure the essence of the spatial relations of shape rules, while 'numbers' introduce their dynamic dimensional significance.

### ***De re aedificatoria a pre-digital parametric model***

The process of inferring shape rules directly from the reading of *De re aedificatoria* exposed the algorithmic nature of their content. Alberti notations on the sacred buildings parts are described in terms of numerical qualities and quantities defining their pro-

portional and morphological dependency. Thus, the schema presented in Figure 1 and the shape rules illustrated in Figure 2 feature the possibility of assigning different values to their dimensional parameters and also by the interdependencies between the cell and chapels dimensions and location, resulting in a parametric shape rule. This kind of relations is repeated in other shape rules resulting in a parametric grammar (Stiny, 1980).

Like the initial grammar, the transformed grammar still is a parametric grammar. Therefore, each derivation of the grammar can potentially generate a family of design solutions, rather than one single solution. A computational parametric model was developed in Grasshopper with the aim of managing the generation of multiple design solutions within the grammar (Grasshopper is a Visual Programming Interface that interacts with modeling software Rhinoceros. A program written in Grasshopper consists of a combination of interlinked components performing operations on primitives, usually but not necessarily geometrical ones. This programming paradigm allows visually developing parametric geometrical models, whose outputs correspond to a family of solutions). The parametric model encodes the knowledge gathered in the grammar inferring and transformation processes. The output depends on the variation of parameters, which correspond to what Alberti prescribes for the number and dimensions of the elements that should, according to the author's theory and practice, conform the temple (Figure 5).

In the last three decades, computational tools

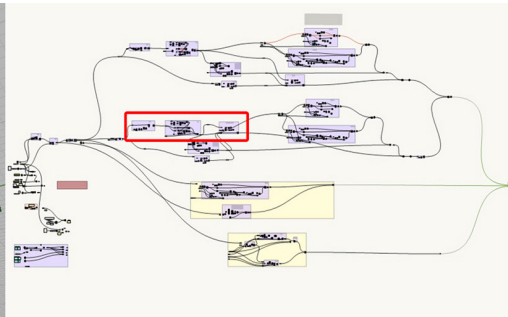
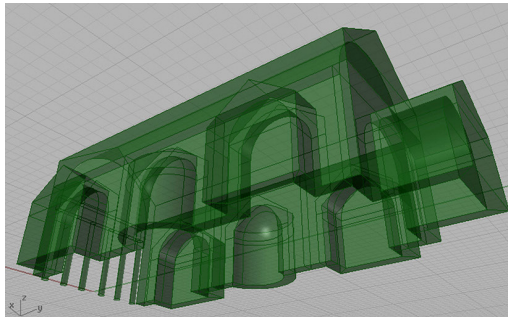

Figure 5  
Parametric model and one possible design solution<sup>99</sup>.

gained an extraordinary importance in the contemporary architectural discourse. Parametric design is one of the computational models that acquired more relevance in these process. Despite their importance, little discussion has been given to the use of parametric design in a pre-digital era. The translation of Alberti's work into a shape grammar revealed that the *De re aedificatoria's* descriptions of sacred buildings is precursor to the use of parametric design to define a set of architectonic principles. Thus, it is inevitable that a research on *De re aedificatoria* today gives rise to its implementation as a computational model.

## CONCLUSION

The variety of context and the role that Alberti had in the design of his buildings results in very specific knowledge that can be retrieved from them. Thus, the sole analysis of the buildings were not sufficient to set up rules defining a consistent architectural typology. Furthermore, they do not always verify his treatise's principles. Regarding to this subject, Tavernor (1996, p. 178) remembers that Alberti (IX, 10, p.137) made reference to the difficulty of translating his theoretical principles in a successful design: "I can say this of myself: I have often conceived of projects in the mind that seemed quite commendable at the time; but when I translated them into drawings, I found several errors in the very part that delight me most, and quite serious ones; again, when I return to drawings, and measure the dimensions, I recognize and lament my carelessness; finally when

I pass from the drawings to the model, I sometimes notice further mistakes in the individual parts, even over the numbers"

Despite this incongruity, the analysis of the buildings contributed for the systematization of a coherent body knowledge of Albertian sacred buildings because our focus on the buildings was constrained by our concern for the structure of the treatise grammar.

The methodology presented for the inference of transformations of the treatise shape grammar contributed for encoding new knowledge into the grammar. Although, the algorithmic nature of the treatise descriptions eased the task of matching building proportions and morphology with the grammar shape rules, this reinforces the notion that inferring rules from the analysis of a corpus of existing buildings is an adequate tool to reinforce a grammar's capability for generating solutions in accordance to both textual and design descriptions (Mitchell, 1990).

Both shape grammar and parametric model implementations prove to be effective tools for generating design solutions in the same style. The former introduces a step by step computation that reinforces the visual perception of formal transformations. The latter, by automating the process of generation, emphasizes the variation on the solutions by controlling their parameters. Even though their structure has different philosophies, they used the same knowledge on the design, resulting in the same corpus of solutions.



Given the objectives of the project Digital Alberti, it is supposed to expand the methodology presented to a set of sacred buildings, representative of classical Portuguese architecture. The aim of this analysis is to identify possible deviations and similitude between Alberti theoretical and design principles and classical Portuguese architecture. The results of these investigations it will be presented in future essays.

## ACKNOWLEDGEMENTS

This work is funded by FEDER Grants through COMPETE – Programa Operacional Factores de Competitividade and by National Grants through FCT – Fundação para a Ciência e a Tecnologia, as part of the “Digital Alberti” project (PTDC/AUR-AQI/108274/2008 – FCOMP-01-0124-FED-ER-008842). The project is hosted by CES at the University of Coimbra and ICIST at the Technical University of Lisbon, and coordinated by Mário Krüger. Bruno Figueiredo is funded by FCT with PhD grant DFRH -SFRH/BD/69910/2010.

The evolution of this work is in debt with Prof. Terry Knight due to her immensely helpful comments.

## REFERENCES

- Alberti, LB 2011, *Da arte edificatória*, AME Santo (translation), MJT Krüger (introduction and notes), Calouste Gulbenkian Foundation, Lisbon.
- Borsi, F 1977, *Leon Battista Alberti*, Phaidon, Oxford.
- Branco, RL 2008, *Italianismo e Contra-Reforma: a obra do arquitecto Baltasar Álvares em Lisboa*, FCSH-UNL, master thesis, Lisbon.
- Coutinho, F, Castro e Costa, E, Duarte, JP and Krüger, M 2011, 'A computational interpretation of "De re aedificatoria": Translating Alberti's column system into a shape grammar' in *RESPECTING FRAGILE PLACES - 29th eCAADe Conference Proceedings*, University of Ljubljana, Faculty of Architecture (Slovenia), pp.788–798.
- Duarte, JP 2008, *Synthesis Lesson - Mass Customization: Models and Algorithms*, Aggregation Exams, FAUTL, Lisbon.
- Duarte, J, Kruger M, Coutinho, F, Figueiredo, B and Castro e Costa, E 2013, 'Alberti Digital: Investigando a influência

de Alberti na arquitectura portuguesa da contrarreforma' in CAL Brandão, P Caye, F Furlan and MA Loureiro, *Na Gênese das Racionalidades Modernas: Em torno de Leon Battista Alberti*, Editora UFMG, Belo Horizonte, Brasil, pp.488-548.

- Figueiredo, B, Castro e Costa, E, Duarte, JP and Krüger, M 2013, 'Digital Temples: a Shape Grammar ro Generate sacred buildings according to Alberti's theory' in JP Sousa and JP Xavuir (eds.), *Future Traditions - Rethinking Traditions and Envisioning the Future in Architecture Through the Use of Digital Technologies*, Faculdade de Arquitectura da Universidade do Porto, Porto, Portugal , pp.63–70.
- Li, AI 2002 'Algorithmic architecture in twelfth-century China: the yingzao fashi', in F Rodrigues and K Williams, (eds.), *Nexus IV: architecture and mathematics*, Kim Williams Books, Fucechio, Italy, pp.141–150.
- March, L 1996, 'Renaissance mathematics and architectural proportion in Alberti's *De re aedificatoria*', *Architectural Research Quartely*, vol.2, pp.54-65.
- Moreira, R 1991, 'A Arquitectura do Renascimento no sul de Portugal. A encomenda régia entre o Moderno e o Romano', Ph.D. thesis, FCSH-UNL, Lisbon.
- Moreira, R 1995 'Arquitectura: Renascimento e Classicismo' in P Pereira (ed.), *História da Arte Portuguesa Vol II*, Circulo dos Leitores, Lisbon, pp. 302-375.
- Krüger, M and Duarte, J P and Coutinho F 2011 'Decoding *De Re Aedificatoria*: using grammars to trace Alberti's influence on Portuguese classical architecture' in K Williams, JN Tavares and JP Xavier (eds), *Nexus Network Journal*, 13, no. 1, pp.171-182.
- Knight, TW 1983, 'Transformations of language of design', in *Environment and Planning B: Planning and Design* 10, pp.125-177.
- Rykwert, J, Leach, N and Tavernor, R 1988, *On the Art of Building. De Re Aedificatoria*, MIT Press, Cambridge, Massachusetts.
- Rykwert, J and Angel, A 1994, *Leon Battista Alberti: Catalogo della mostra Palazzo Te*, Olivetti and Electa, Milan.
- Soromenho, M 1995, 'Do Escorial a São Vicente de Fora: Algumas notas sobre Filipe II e a arquitectura portuguesa' in *Monumentos* 2, Direcção Geral dos Edifícios e Monumentos Nacionais, Lisbon, pp. 24-26.
- Stiny, G and Gips, J 1972: 'Shape Grammars and the Genera-

tive Specification of Painting and Sculpture; *Computer*,  
71, 125–135.

Stiny, G. 1980, 'Introduction to Shape and Shape Grammars',  
in *Environment and Planning B: Planning and Design* 7,  
pp. 343-352.

[1] <http://www.bath.ac.uk/casa/alberti/index.html>

[2] <http://www.emis.de/journals/NNJ/Query03-Quality.html>