

Outcomes of the DeepWind conceptual design

Paulsen, US; Borg, M.; Madsen, HA; Pedersen, TF; Hattel, J; Ritchie, E.; Ferreira, Carlos; Svendsen, H.; Berthelsen, P.A.; Smadja, C.

DOI

[10.1016/j.egypro.2015.11.437](https://doi.org/10.1016/j.egypro.2015.11.437)

Publication date

2015

Document Version

Final published version

Published in

Energy Procedia

Citation (APA)

Paulsen, US., Borg, M., Madsen, HA., Pedersen, TF., Hattel, J., Ritchie, E., Ferreira, C., Svendsen, H., Berthelsen, P. A., & Smadja, C. (2015). Outcomes of the DeepWind conceptual design. *Energy Procedia*, 80, 329-341. <https://doi.org/10.1016/j.egypro.2015.11.437>

Important note

To cite this publication, please use the final published version (if applicable).
Please check the document version above.

Copyright

Other than for strictly personal use, it is not permitted to download, forward or distribute the text or part of it, without the consent of the author(s) and/or copyright holder(s), unless the work is under an open content license such as Creative Commons.

Takedown policy

Please contact us and provide details if you believe this document breaches copyrights.
We will remove access to the work immediately and investigate your claim.



12th Deep Sea Offshore Wind R&D Conference, EERA DeepWind'2015

Outcomes of the DeepWind conceptual design

Uwe S. Paulsen^{a*}, Michael Borg^a, Helge Aa. Madsen^a, Troels Friis Pedersen^a, Jesper Hattel^b, Ewen Ritchie^c, Carlos S. Ferreira^d, Harald Svendsen^e, Petter A. Berthelsen^f, Charles Smadja^g

^aDanish Technical University DTU, Department of Wind Energy, Frederiksborgvej 399, Dk-4000 Roskilde, Denmark

^bDanish Technical University DTU, Department of Mechanical Engineering, Produktionstorvet Building 425, DK-2800 Lyngby, Denmark

^cÅlborg University, Department of Energy Technology, Pontoppidanstræde 101, 67, Dk-9220 Ålborg, Denmark

^dTU Delft Wind Energy Research Institute Building, Kluyverweg 1 2629 HS Delft The Netherlands

^eSINTEF Energy Research, Box 4761 Sluppen, NO-7465 Trondheim, Norway

^fNorwegian Marine Technology Research Institute (MARINTEK), POB 4125 Valentinlyst, NO-7450 Trondheim, Norway

^gNENUPHAR SARL Campus de l'Institut Pasteur 1 Rue du Professeur Calmette 59000 Lille, France

Abstract

DeepWind has been presented as a novel floating offshore wind turbine concept with cost reduction potentials. Twelve international partners developed a Darrieus type floating turbine with new materials and technologies for deep-sea offshore environment. This paper summarizes results of the 5 MW DeepWind conceptual design. The concept was evaluated at the Hywind test site, described on its few components, in particular on the modified Troposkien blade shape and airfoil design. The feasibility of upscaling from 5 MW to 20 MW is discussed, taking into account the results from testing the Deepwind floating 1 kW demonstrator. The 5 MW simulation results, loading and performance are compared to the OC3-NREL 5 MW wind turbine. Finally the paper elaborates the conceptual design on cost modelling.

© 2015 The Authors. Published by Elsevier Ltd. This is an open access article under the CC BY-NC-ND license (<http://creativecommons.org/licenses/by-nc-nd/4.0/>).

Peer-review under responsibility of SINTEF Energi AS

Keywords: Vertical-axis wind turbine; offshore floating platform; DeepWind; aerodynamics, hydrodynamics, pultrusion; structural optimization; floater; permanent magnet generator; magnetic bearings; controls; safety; cost models

* Corresponding author, Tel +45 46775044; fax: +4546775083
E-mail address: uwpa@dtu.dk

1. 5MW conceptual design advances

The conceptual design development from concept to present design has been described in various steps on advances in design, cost reduction potentials and challenges with the technology in technical papers [1-3]. The present paper is also supplemented by a review on the particular aspects of simultaneous engineering of the conceptual design [4]. The concept consists of the following main components: rotor and tower connecting rotor blades, floater (rotating spar buoy), generator and torque absorption system, and mooring system. The electronics for control of the 5 MW concept is embedded on a nearby separate substation. The present conceptual design specifications on the main performance and geometry are shown in Table 1 and a 3D sketch of the turbine is shown in Figure 1, right, together with a principal sketch of the concept for load simulations.

Table 1. Main specification of 5 MW.

Operational and Performance Data				Geometry	
Rated power	[MW]	5	Rotor radius (R)	[m]	60.49
Rated rotational speed	[rpm]	5.95	Rotor height (H)	[m]	143
Rated wind speed	[m/s]	15	Chord (c)	[m]	5
Cut in wind speed	[m/s]	4	Solidity ($\sigma = Nc/R$)	[%]	16.53
Cut out wind speed	[m/s]	25	Swept Area	[m ²]	11996

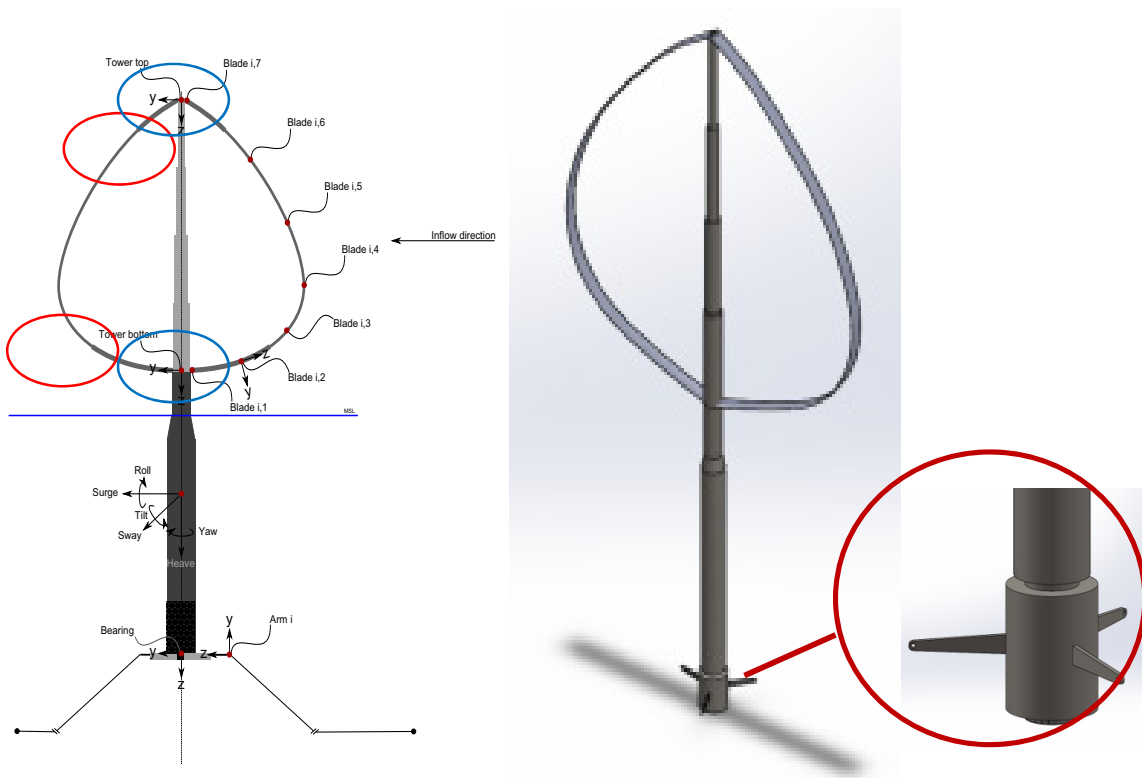

Figure 1 Left: Schematic overview of 5MW DeepWind, with indication of blade connections (circles). Right: 3D drawing of 5MW concept. Detail of generator and torque absorption system shown

1.1. Rotor

From a structural and aeroelastic point of view a thick profile is preferred because this facilitates a lightweight blade with elastic properties that reduces the risk of unstable behavior during operation. But a thick profile has a higher drag and this compromises the performance. During the project the design work on a thick profile continued, but for structural and aeroelastic simulations, a symmetric NACA profile was chosen for several reasons. The structural properties are very similar to the suggestions for the thick profile and with the NACA profile it is very easy to change the thickness of the profile and perform parametric investigations. The NACA profile is also used in many comparable studies, and this makes it easier to validate the calculations. Several combinations of sections were investigated and for each combination an optimization of the blade shape was performed [3, 4]. The resulting shape is shown in Figure 2 with 18% NACA profiles for the majority of the blade length and 25% NACA profiles close to the rotor axis. This configuration is well suited to the use of a blade pultrusion manufacturing process.

Parallel to the structural/aeroelastic calculations, investigations regarding the aerodynamic performance of thick profiles were conducted. Previous work on airfoil development (see [6] for a review) applied concepts developed from aeronautical and horizontal axis wind turbine applications; these airfoils allowed for high power coefficients,

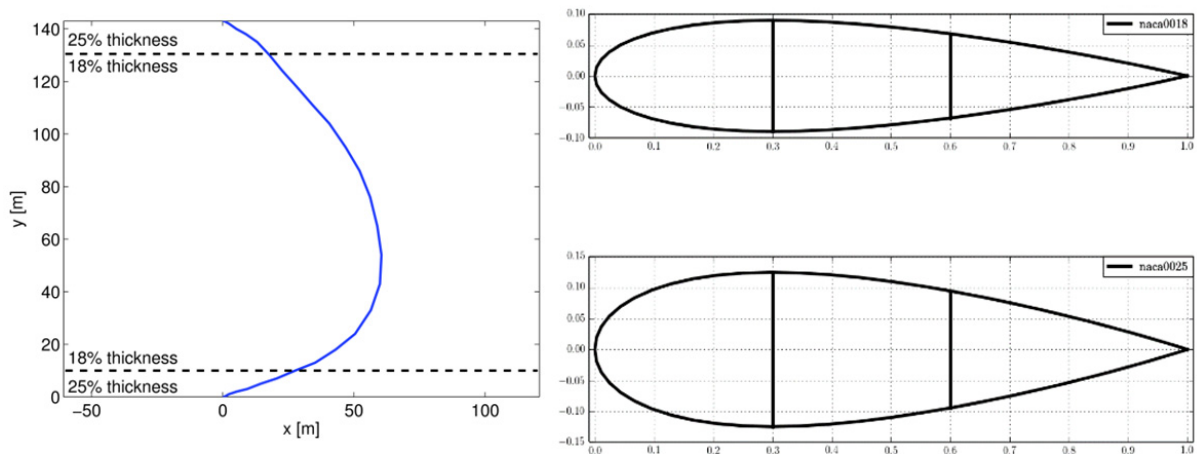

Figure 2 Left: Modified Troposkien shape of final rotor design. Right: NACA 0018 and NACA0025 airfoils sections used for blades

but were at most 21% thick. In the Deepwind project, a new expression was analytically derived for the performance optimum for VAWT airfoil and related this to airfoil thickness (see [6]). A genetic optimization approach was developed to generate families of airfoils that were applied in VAWT simulations, confirming gains in aerodynamic and structural performance. Using such new airfoil family in the demonstration of the concept on a 1 kW rotor (DU06W200) confirmed a slight increase in higher performance, compared to using a NACA0018 airfoil.

To further demonstrate the approach, a new 26.2% thick airfoil was designed, the DU12W262. A DU12W262 model was designed and tested in TU Delft's low Turbulence Wind Tunnel. The wind tunnel test and the validation have been performed at a Reynolds number of 1×10^6 , since full scale Reynolds number testing for the 5 MW machine (in the order of 1×10^7) could not be done in the available test facility. As the validation with XFOIL gave good results the airfoil characteristics have been extrapolated with XFOIL at the higher Reynolds numbers typical of a 5 MW turbine. The extrapolated DU12W262 data were selected for aerodynamic performance investigations and 2-D VAWT results for the 5 MW version showed in comparison with reference NACA symmetric airfoils an increase in CP; the thick airfoil has also a favorable bending stiffness index. Figure 3 shows the results of the simulated power coefficient (CP) as a function of tip speed ratio (λ) considering the maximum CP for the considered range of solidity of the DU12W262 for a Reynolds number of 1×10^7 with free transition.

From the beginning of the project, it was intended that the blade should be made in glass fiber reinforced plastics (GRP) and utilize the pultrusion manufacturing process. The thickness of the material and the internal structure was modelled on previous designs. The size of the blade infers that it is not possible to manufacture the blade as a single element and solutions for joining the blade have to be investigated, however this is outside the scope of this work. A solution for joining the sections has been presented [4]. The tower is an integral part of the rotor and is designed with the use of welded construction steel. These constructions are well known from towers for horizontal wind turbines, and are calculated with the use of eurocodes. The limiting factor in the design is the fatigue loads on the tower which were a part of the aeroelastic analysis.

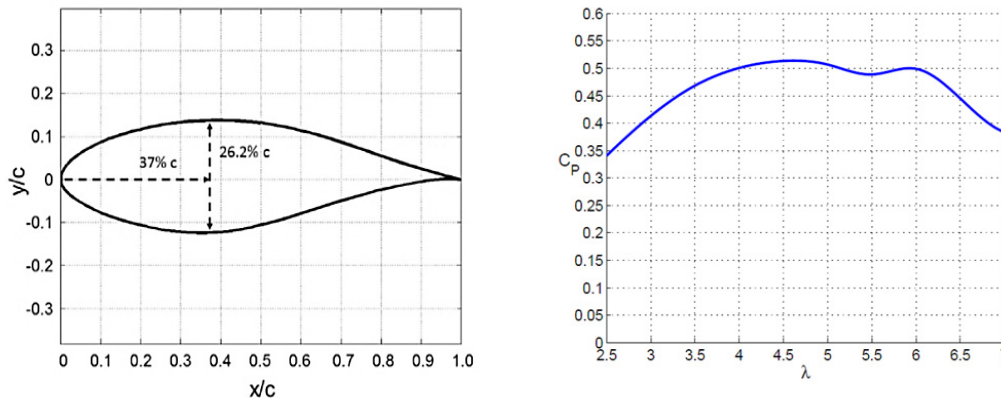

Figure 3 Left: DU12W264 profile intended for 5 MW concept. Right: Simulated power coefficient (C_P) of a two bladed VAWT as a function of tip speed ratio (λ) based on Re-extrapolation of the measured C_I - C_d curves.

1.2. Floater

The DeepWind project is based on a spar type floater. The spar is a deep draught vertical circular cylinder with buoyancy chambers at the upper part and a heavier section at the lower end for stabilization. The draught is usually deep enough to limit vertical wave forces such that the vertical motions of the spar buoy are rather small. A stable spar buoy design requires that the mass centre is located below the centre of buoyancy, ensuring that the floater stays upright with low roll and pitch motion. The upper part of the spar buoy is narrowed such that a small cross-sectional diameter is obtained in the wave zone, which limits the wave loads on the structure, and gives a vertical resonance period well above the energetic wave period range. The spar concept is commonly used in the offshore oil and gas industry as deep water production platforms, and it has shown to be a promising solution also for floating offshore wind turbines due to its favorable motion behavior. Floater characteristics of the DeepWind concept have been described during the iterations [2-5].

The selection of hull shape and size depends on functional requirements, and the following basic design requirements were considered for this floating wind turbine:

- Natural periods in heave and roll/pitch should be larger than the dominating wave periods to avoid resonant motion response
- Sufficient buoyancy to carry specified payload and weight of the mooring system
- Sufficient vertical stiffness for variable vertical load
- Sufficient stiffness in roll and pitch to avoid excessive tilting of turbine axis due to environmental loads
- Acceleration should be limited to avoid damage to machinery components

The initial and final floater concept is sketched in Figure 4. Main specification of the final floater design is shown in Table 2. Besides the environmental conditions, the dimension of the floater is mainly governed by the rotor design (both weight distribution and aerodynamic loads) and the specified payload (such as size and mass

properties of the generator). Changes to the rotor or generator design alter the shape and size of the spar hull. Presently the power loss due to friction from the rotating tube in water is affected in operation and constrained to be less than 5%.

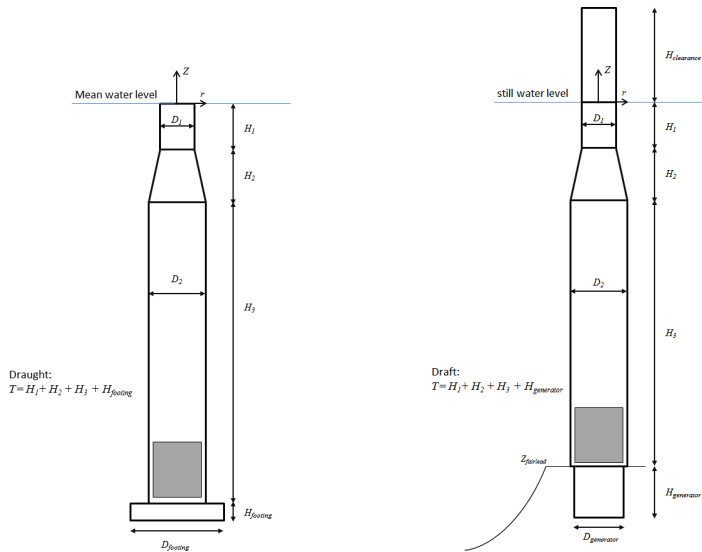

Figure 4 Left: 1st iteration design. Right: final floater design

Table 2. Main spar hull specification of 5 MW designs.

	Parameter	unit	Initial reference	Final design
Wall thickness	τ	[mm]	50	50
Height clearance section	$H_{clearance}$	[m]		15.0
Height upper section	H_1	[m]	5	5.0
Height tapered section	H_2	[m]	10	10.0
Height main section	H_3	[m]	91.55	80.0
Height generator	$H_{generator}$	[m]	1.45	13
Draught	T	[m]	108	108.0
Upper diameter	D_1	[m]	6.3	6.8
Main diameter	D_2	[m]	8.3	8.0
Generator box diameter	$D_{generator}$	[m]	10.6	7.4
Displaced Volume	V	[m ³]	5658.39	5193.0
Centre of buoyancy	Z_B	[m]	-56.48	-54.46
Water plane area	A_w	[m ²]	31.17	36.32
Displacement	Δ	[t]	5799.85	5322.8
Position fairlead	$Z_{fairlead}$	[m]	-108	-95.0

1.3. Generator module

General description of generator system

The general description of the power conversion system is given in Figure 5. The shaft power applied by the wind turbine rotor is converted to electrical power in the direct drive, permanent magnet generator that operates at variable speed according to the reference speed supplied by the turbine controller. This means that the electrical output of the generator is at variable voltage and frequency. A full power, inverter converts this to constant frequency, constant voltage output suitable for connection to the grid. As the Darrieus wind turbine is not self-starting, the inverter is suitable for four quadrant operation to enable the generator to be used as a motor during the starting period. This enables the generator to be used as a brake, in almost all fault situations, as a dump resistor is also proposed. All shaft torques are transferred to the mooring system that provides the necessary reaction torque.

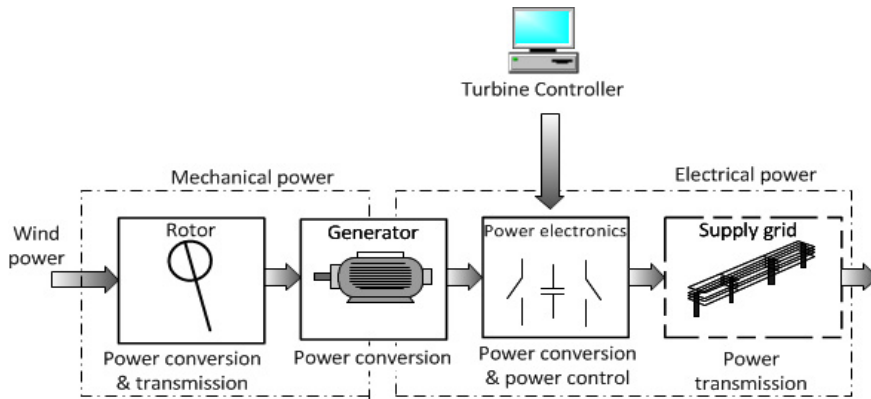

Figure 5 Diagram showing the general arrangement of the generator system and power flow.

As the DeepWind design calls for the generator to be mounted at the bottom of the floater, the entire electrical system is subsea. The generator contains bearings, two journal - and two thrust bearings. These bearings support all loads arising in the system, transferring them to the mooring system that provides the necessary reaction forces. Controlled magnetic bearings are proposed as these can support the forces, preventing touchdown at all speeds, including standstill.

Generator Design Tool

To facilitate informed interaction with the wind turbine engineers and the marine anchoring engineers the NESSIE design tool was created, [7]. This synthesises the electromagnetic mechanical design of the generator. It interfaces with the operator via a GUI. The GUI offers a range of inputs. In the area marked 'Inputs', the desired generator performance may be selected.

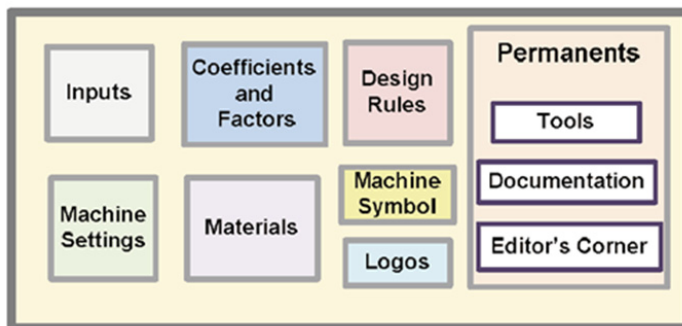

Figure 6 Map of NESSIE design tool GUI.

All the other areas offer possibilities to influence the algorithm or to obtain information on how the algorithm functions. The tool is very flexible and offers a range of outputs such as a design sheet file containing a list of inputs, dimensions and performances, direct interface with Solid Works CAD program, direct interface with Vector Fields OPERA electromagnetic finite element program. The CAD program enables 3D visualisation of the generator construction and provides rapid generation of working drawings. Among other benefits, OPERA enables verification of the NESSIE calculation results, visualisation of the magnetic field, and prediction of unbalanced forces arising internally in the generator itself. NESSIE provides for a range of machine types with radial and transverse flux. The NESSIE program is written in a modularised way so that it may be modified by change or by addition of functions by a suitable operator. Additional tools may be accessed from the GUI, such as optimisation programs, etc. The NESSIE design tool is fully documented in [7].

DeepWind Generators

Three generator designs with different rated power were produced: a nominally 1 kW design for the small size demonstrator, a 5 MW and a 20 MW full size design. Some key figures are listed below. Following much discussion on the placement of the generator in relation to the floater and the mooring system it was agreed that for the 5 MW design, the floater should transit to a shaft that carried the rotor of the generator.

Table 3 Key figures for DeepWind Generators

Attribute	1 kW	5MW	20MW
Shaft Input Power	1.58 [kW]	6.2[MW]	22.5 [MW]
Shaft speed	430 [rpm]	5.63 [rpm]	1 [rpm]
Rated Input torque †	35 [Nm]	10.5 [MNm]	215[MNm]
Depth under water	<4.5 [m]	~ 150 [m]	~ 200 [m]
Efficiency ‡	0.85	0.9	0.9
Output frequency	~50 [Hz]	~15 [Hz]	~6 [Hz]
Output Voltage rms	3*400 [V]	3*13 [kV]	3*20 [kV]
Output Current rms	ca. 1.8 [A]	ca. 0.22 [kA]	ca. 577 [A]
Output Apparent Power	ca. 1.25 [kVA]	ca. 5 [MVA]	ca. 20 [MVA]
Output Real Power	1 [kW]	5.58 [MW]	20 [MW]

The stator was attached to the anchor plate that was provided with torque arms connected to the anchor cables. The shaft rotates in controlled magnetic bearings that carry the wind turbine. Spiders are employed to adjust the dimensions where necessary. The generator enclosure is relatively flimsy supported by an arrangement of ribs and buttresses to minimise the material usage. An external structure, not shown here, was proposed to provide ballast and buoyancy when required.

To save material, the 20 MW generator is proposed to be built inside the floater with the generator rotor fitted to the floater inner surface. The stub shaft will be attached to the anchor plate and the stator attached to this. To utilise the volume inside the stator, it is proposed to house the power electronics equipment here. This includes the electronics required for the controlled magnetic bearings. Studies are proposed to determine if it is possible to fill the generator with water for cooling purposes. This will eliminate the need for a seal that would wear. Access for maintenance purposes is envisaged to be from inside the floater through a manhole. Modular construction will enable small sections of the generator to be removed for maintenance purposes.

Converter

The converter proposed for the 5 MW and 20MW versions is a full power, three level four quadrant inverter. New types of SiC semiconductor switch are being developed, where it will be possible to eliminate the transformer, by operating the converter at full grid voltage. This will improve the reliability on two counts. The transformer is eliminated, and the current being switched by the semiconductor devices is reduced. This converter configuration provides the ability to start the turbine rotor by driving the generator as a motor, controlled normal operation as a generator, and braking under normal conditions as required. Addition of a dump resistor in the DC link circuit will enable the generator to be used as an emergency brake if the grid connection is lost.

Bearing Design Tool

A design tool was made for the bearings that takes the forces and dimensions as input, and proposes a design for journal bearings and thrust bearings. Output includes the bearing dimensions and the necessary capacity of the bearing power supply as well as the associated material costs. This enabled rapid response to changes of forces and bearing position, determining the costs associated with proposals for changes of the external parameters. The design tool was verified by tests on a small scale laboratory model [3].

Internal forces arise in the generator because of imperfect centring of the rotor in the stator bore. This is known as Unbalanced Magnetic Pull (UMP). This force may become very large if the rotor is eccentric in the stator bore. Eccentricities may arise from manufacturing imperfections, or from static or dynamic loading of the shaft and

† Torque is inversely proportional to shaft speed for a given power and is a deciding factor for the machine diameter.

‡ NB. Reductions in efficiency cause increases in torque required to provide the rated power!

bearings. This arises independent of the type of bearing used. As we are proposing a controlled magnetic bearing, it is possible to specify the eccentricity of the shaft at the bearing. Other factors affecting the UMP are the flux density in the air-gap of the generator and the surface area of the stator bore. Equation (1) was used to estimate the UMP, using the air-gap flux density at No-Load condition, as this is the conservative choice; the air-gap flux density from the permanent magnets is greatest under this condition. The eccentricity was specified as 10% of the air-gap length.

$$F_{UMP} = \epsilon \cdot \frac{B_{gap}^2}{2 \cdot \mu_0} \cdot \pi \cdot D_{gap} \cdot \frac{L_{EFF}}{2} \quad (1)$$

F_{UMP} is here estimated at the shaft with a shaft speed of 5.73 rpm used for the generator design. The bearings were designed using the principles studied and laid down in [9], using a specially written design program 'DWControlledMagBrg' to synthesise the dimensions required. It remains to dimension the power controllers and the control system. The mean power required for the journal bearings is a total of about 100 kW, some 2% of the 5 MW rated power.

Further studies of the dynamic behaviour of the turbine rotor, floater and mooring system with actual met-ocean data may enable the mean required power to be reduced, by reducing the air-gap. This will also reduce the performance requirements of the power controller. The large magnetic bearings technology might relax on the constraint of having the generator module at the bottom section of the floater, and suggested work could in future provide a design with a shorter spar hull.

1.4. Mooring system

Basic design requirements for mooring systems are, that the extreme tension in the mooring lines should be less than the breaking strength (scaled by a safety factor), and have as well as sufficient fatigue life, sufficient horizontal stiffness to limit floater offset, sufficiently compliant (soft) system to avoid resonant motion induced by first order wave forces, adequate static horizontal pretension to provide sufficient yaw stiffness and redundancy. The mooring lines for the DeepWind concept were designed to withstand the large yaw moment from the rotating turbine. This requires a considerable stiffness in yaw determined from a combination of the fairlead length and the mooring cable stiffness. The conceptual study considered two mooring system configurations with a 3 line chain system, where the lines are evenly spread at 120 degrees, and a 6 line chain system, where the lines are evenly spread at 60 degrees. Other cable types, such as light synthetic fibre cables, were not considered.

2. DeepWind simulations

Simulations were carried out on the Figure 1 indicated concept. Details of the setup, assumptions and load cases are given in the detailed loads report [10], and results have been communicated for similar concepts [3, 4]. Simulations were performed at wind speeds from 4 to 24 m/s in both deterministic wind with a standard power law wind shear, and in turbulent inflow (IEC Class C). Four different sea states were simulated [4]. An investigation on the assumptions and prerequisites for the concept [11] was carried out with respect to applying constant currents with depth along the rotating spar. Including met-ocean measurements obtained at Karmøy near the Hywind site shows, that water currents and hence Magnus forces decrease as expected with sea depth, but varies over time unexpectedly along the tube due to other, yet unknown effects. Measured met-ocean, or Hindcast modelled data sets are of high importance for determination of accurate loads. The required journal- and thrust bearings power and hence the systems efficiency is likely estimated conservative; the load cases are regarded qualitatively approximate in the present simulations.

The floater system design optimization was performed in line with the loads condition at 24 m/s, and within the approach of simultaneous engineering performed. The rotor loads were however referenced at a position different from the required section, with a floater design which is not fitting perfectly.

In general the aeroelastic responses below rated wind speed/power was stable but for the operation above rated wind speed where stall occurs over a main part of the blade two major instabilities were encountered. One of the instabilities was edgewise blade vibrations which are a well-known problem for both stall controlled VAWTs and

HAWTs. To explore the instability into some details several sets of about 1500 simulations of a time length of 500 seconds were simulated, where blade stiffness and rotational speed was varied for all wind speeds in the operational range. The results showed that in a final design process an accurate aeroelastic tailoring of turbine design parameters like rotational speed and blade stiffness is necessary to obtain a stable operation in stall. However, for the present analysis it was chosen to run with stiff blade properties in order to achieve realistic overall dynamic load properties and turbine response such as tilt and roll characteristics.

Another major instability encountered was a motion dominated by the yaw degree of freedom in the mooring system. Again the problem was most severe during stall operation. Major dominating parameters were the edgewise flexibility of the blades, the tower torsion flexibility and the control system combined with the strong 2p dynamic torque input. A design change in the mooring system to torque arms of 15 m and a drag coefficient of 1 for the hydrodynamic motion reduced the problem to a reasonably level.

A main characteristic of the Deepwind design is the rotating floater which causes a Magnus force on the floater when there is a current in the sea. In the initial design studies there was some concern if this could be a stop barrier for the concept but the present hydro-aero elastic simulations show that the roll for the sea state conditions of the present site is lower than pitch caused by the aerodynamic thrust force [10]. It is thus clear that the Magnus force loading is not a show stopper for the present concept.

The mooring system design required some special attention due to the large yaw moment caused by the rotating turbine. Minimum yaw stiffness is required in order to balance the wind induced yaw moment, and yaw stiffness is determined by the fairlead radius, the horizontal component of pretension and the number of mooring lines. To avoid too high loads on the mooring lines and fairlead connection, one possibility is to use a mooring configuration consisting of several mooring lines. The present results indicate that the cost for the additional lines for a 6-line configuration compared to a 3-line system is only marginal. The reason for this is that the 6 lines require smaller chain diameters due to less load per line. Low line tension is also positive with respect to fatigue. One important difference between the 3- and the 6-line system with respect to design is that the 6-line system has redundancy and will not pose any threat to neighbouring wind turbines in case of a line failure. The offshore standard DNV-OS-E301 recommends an increase in safety factors for non-redundant systems.

3. Upscaling

The first experiences with the DeepWind design were gathered from a 1 kW demonstrator wind turbine. The design of this wind turbine was not based on downscaling a large turbine. The design was made as a concept 1 kW turbine. The consequences of this design philosophy are clearly seen in comparison of the 1 kW demonstrator with the baseline 5 MW wind turbine in Figure 7, left. Here the two designs are shown for equal rotor size but with a scaling factor of 71:1. The main difference lies in the floating part of the turbine concept. The mass is a key issue—any kilogram of mass reduced on the model turbine reduces necessary buoyancy by a litre. And any reduced litre of buoyancy that can be taken away reduces the floater diameter. Lastly, a reduction of floater diameter by 1% reduces the friction by 4%.

Application of geometric scaling laws is a fight for reduction of mass of the model. The 1 kW demonstrator was made to work under real subsea conditions. A scaled model tested in controlled water basins can be designed for lower design loads. In this respect it is most appropriate to move into stronger materials such as carbon fibre for construction details. Instrumentation in the turbine itself may be avoided by use of a wind-scanner for wind measurements and use of stereovision technology for monitoring of response measurements.

When not applying the scaling laws the design philosophy to compare small scale wind turbine measurements with simulation tools to verify the simulation tools seem to be an alternative method to provide knowledge of a new concept. The simulation tools are “scalable” from physical laws and are paramount to design of large turbines. The development of appropriate simulation tools in parallel to turbine testing is thus a prerequisite for design of larger turbines. An example of linear scaling, for deriving the 20 MW from the 5 MW rotor, is shown in Figure 7. The design and production of the 1 kW demonstrator to and tests in the local surroundings gave a significant experience, not just in design and production, but also in deployment, operation, and dismantling of the system in offshore conditions. The experience of a smooth operating and more damped construction than a land-based

construction is a visual experience that may be compared to the way a tree sways in the turbulent wind. The use of a special built vessel is an experience that might be further developed into deployment and maintenance of larger turbines. The deployment of the demonstrator was not simple since the turbine was connected to a measurement mast on a common platform, all to be operated and maintained from the surface, as a traditional test-setup. Deployment of a turbine alone is simpler and to this end the use of experiments in the fjord is an advantage compared to very expensive water basin testing.

The demonstrator was tested for proof-of-concept tests in Roskilde fjord, Denmark in waters of 4.5 m depth. The wind turbine was then tested in the offshore Marin basin under controlled conditions. After the demonstrator tests, the full-size baseline 5 MW wind turbine was designed, and the DeepWind demonstrator was compared to

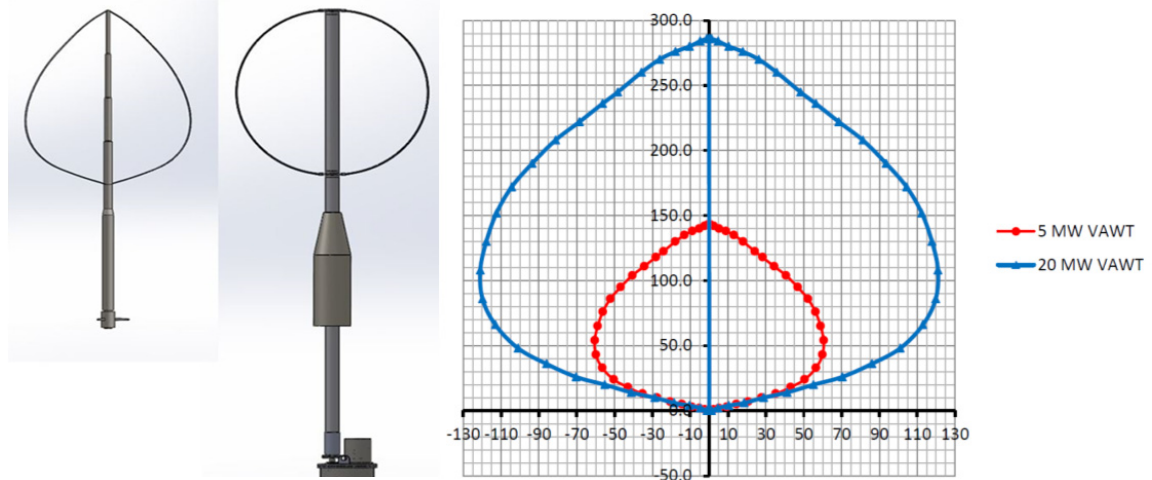

Figure 7 Left Scaling of dimensions 70.71:1 of 5MW design concept to 1kW demonstrator showing relative drastic reduced mass and subsea components of 5MW system. Right: 1:2 Scaling of 5 MW to 20 MW

the 5 MW baseline design from a scaling point of view. The comparison shows very different designs. The demonstrator floater part was 36% longer than optimum. The generator box was about four times larger in dimensions, and the floater diameter about 28% larger. The DeepWind demonstrator mass was about ten times as high as an optimal scaled model turbine. This resulted in a very large buoyancy part to counteract the high mass. The large diameter of the buoyancy part resulted in high friction, about 1.8 kW at 300 rpm. During operation in the fjord and in the MARIN ocean basin the electric power of the turbine was never positive. The rotor itself provided a power coefficient of about 38% as demonstrated in wind tunnel tests.

From the experience with the DeepWind demonstrator the application of scaling laws for model testing is rather complex. The basic Froude scaling for hydrodynamic tests in waves in water tanks is not sufficient for model testing of the DeepWind concept. Additionally, aerodynamic scaling and scaling of Magnus forces must be added. Reduction of the mass of a scaled down wind turbine is very important. The use of light and strong materials must be considered. Keeping the mass down reduces the amount of buoyancy and this reduces the floater diameter that again reduces the friction power.

The comparison of the demonstrator 1kW turbine with the baseline 5 MW turbine shows a drastic improvement in concept design. Experimental experience on a larger turbine on perhaps 500 kW in not so deep waters may give further improvements for upscaling to a 5 MW and even a 20 MW turbine.

4. Cost of technology

An industrial-driven cost model and a simplified cost model approach have been developed to derive two more or less independent cost models of the concept that predict the levelised cost of energy (LCOE) of the concept. The costs contributing to the LCOE may be categorized into capital expenditures (CAPEX) and operational expenditures (OPEX). The simplified models assume reasonable, but approximate figures for requiring capital,

technical commodities and services; they are in overall agreement with an offshore cost study [13]. A specific challenge was to acquire reasonable cost estimates from references dealing with floating offshore wind turbine installations, and to reference these on common terms valid for VAWT technology. In the offshore wind sector there is a lack of experience with this kind of technology, which makes the present estimates uncertain. Similar variations are found dealing in acquiring costs of materials and services. The cost of one unit is estimated for the overall optimized design of rotor, floater generator module and mooring system as roughly 1800 €/kW. The cost distribution is shown in Figure 8 for a design where the floater hull is made of steel and of reinforced concrete, respectively. The cost depicted in Figure 8, right is for utilizing reinforced concrete as a floater material, without being analyzed for effects where the structural integrity has to be investigated. The turbine unit cost is with the reinforced concrete floater estimated to 1200 €/kW-a clear indication of improved economy with less costly materials. The upscaling of the 5 MW results to 20 MW with reinforced concrete spar buoy shows an additional cost potential towards 1053 €/kW per unit.

A windfarm layout of 5x20 MW was investigated on the expenditures on capital investment (CAPEX) and on operation (OPEX). The following assumptions were made:

- Tariff fixed at 0.05 €/kWh
- Interest rate fixed at 7%
- Mortgage rate from bank 3%

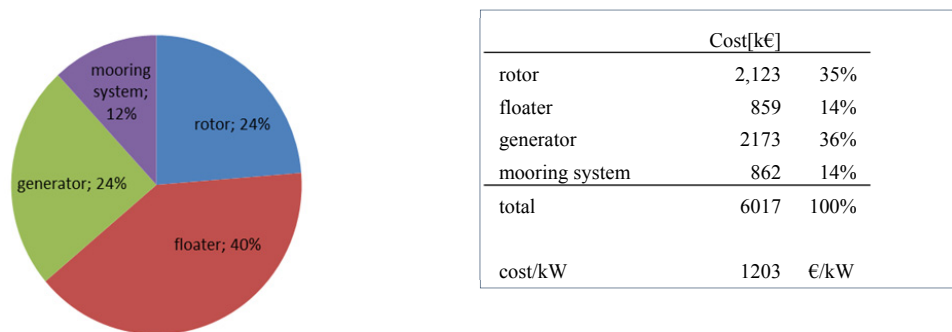

Figure 8 Distribution of components cost of 5MW unit. Left : Floater with steel material. Right: Floater made of reinforced concrete

- 20 years period
- Every 3 years maintenance (135 €/kW, 8 crew members at 59.2 €/h accord, 100 k€ total expense, 1 boat)
- During project two major repairs (9 M€)
- Installation and maintenance schedule with use of ROVs (100 k€), 3 boats, 8 crew members
- Grid networking and substation costs at site (35 M€)
- Soft costs (80 k€)
- Turbine array of 4x5, with 5 D distance and optimized for wake effects
- The rotor efficiency is maintained at same technology level of NACA airfoils

From the numbers, a balance-of-station cost is estimated to € 38,000,000 (380 €/kW), capital expenses to € 11,580,872 (2,316 €/kW) and operation and maintenance to €13,500,000 (135€/kW). The levelized cost of energy (LCOE) estimate over 20 year time is found to be 65 €/MWh. A refined study for a 500 MW Windfarm for a 25 year project time, based on the above assumptions, and worked out on the LCOE sensitivity, resulted in a base LCOE of 62.57 €/MWh with a lower bound of 59.17 €/MWh and an upper bound of 74,63 €/MWh. The industrialized cost model for the 100 MW windfarm (22 years period) provides additional costs such as for return to port and maintenance every 10 years, and accounts with LCOE of about 180 €/MWh. For a 500 MW windfarm, LCOE is 86 €/MWh, with CAPEX around 58 €/MWh, and OPEX around 28 €/MWh.

5. Discussion and concluding remarks

The hydro-servo-aero-elastic computations showed that the DeepWind concept had diverse tuning instability problems originating from a combination of parameters, but not least that the basic design is a stall regulated rotor which is known for its potential instability when operating at high wind speeds. Without going into the details of the nature of these instabilities, one should stress out that for these simulations, five distinct engineering fields are closely interacting with each other: hydrodynamics (floater), structural dynamics (tower, blades, floater, mooring lines), aerodynamics (blades), electro-mechanics (generator), and controls. Each component was initially designed independently (apart from the obvious design specifications). However, the different design models as used for the controller, floater, generator and blades did use some simplified models to account for the some of the most relevant interactions with the other components. Our goal, with a simultaneous engineering approach to provide a conceptual design inheriting optimized subcomponents was not satisfactory achieved, mainly due to limited project time available after finishing the VAWT version of the HAWC2 code and due to major overall design issues on main bearing concepts and generator house design. Initial deeper investigations of e.g. the blade instability that was carried out within the project indicates that a specific aeroelastic tailoring of stiffness properties and control characteristics have to be used for the final system design. We have now engineering tools capable to design 5-20 MW DeepWind concepts, and to simulate loads with results as detailed as for existing wind turbines. The above costs for a 100 MW power plant differ substantially from 2013 experiences on offshore installations [13] –here the installation and investment cost is stated as high as 3400 €/kW (in 2013 €) and the LCOE for offshore wind turbine as 0.119-0.194 €/kWh, for onshore wind turbines the installation cost is between 1000-1800 €/kW (in 2013 €), and the LCOE between 0.045 and 0.107 Euro/kWh. 100 MW DeepWind power plant cost is predicted as 0.065 €/kWh. For the 20 MW the LCOE is expected even lower. However the accumulated income over 20 years with a tariff of 0.05 €/kWh is 1.25 times the expenses. The different cost models and sensitive for variable expenses such as repair, operations and maintenance cost, and capital expenses (initial), and deviations between models are suggested to be followed up. Since there is limited information about the basic cost structure of the DeepWind concept, in particular the cost concerned with maintenance and operation, cost modelling results should be treated with caution.

A quantitative comparison between the DeepWind and the NREL 5 MW Floating Spar Buoy (reference model used in the Offshore Code Comparison Collaborative - OC3) was performed under normal operation conditions. From the comparison it is concluded that the mean power curves for both DeepWind and NREL 5MW floating turbine are largely unaffected by the turbulent inflow against the deterministic inflow. However, the current model stage for DeepWind causes power variations to increase with wind speed, which is different compared to the pitch controlled NREL 5 MW with less power variability. Overall the concept experiences similar loads to the NREL floating wind turbine, but the load predictions are still uncertain as the detailed aeroelastic tailoring of the design mentioned above has not been carried out so that different instabilities have a big impact on the dynamic loads. Also, the predicted AEPs are very similar, despite that the site conditions favour the pitch regulated turbine for lower rated wind speed and hub height.

The two systems experience maximum loads at different operating conditions, with the NREL 5 MW experiences maximum loads around the rated wind speed (12m/s) and the DeepWind experiencing maximum loads at the cut-off wind speed (25m/s). In summary, the DeepWind concept is comparable to the NREL 5 MW floating design although with uncertainty of the impact on the loads on the instabilities in the DeepWind turbine, and further work is warranted to bring this concept forward to be one of the most promising floating wind energy devices.

Acknowledgements

The present work is a result of the contributions within the DeepWind project, supported by the European Commission, Grant 256769 FP7 Energy 2010- Future emerging technologies, and by the DeepWind beneficiaries: DTU(DK), AAU(DK), TUDELFT(NL), TUTRENTO(I), DHI(DK), SINTEF(N), MARINTEK(N), MARIN(NL), NREL(USA), STATOIL(N), VESTAS(DK) and NENUPHAR(F). Dr. Birgitte Furevik, department of Research and Development at the Norwegian Meteorological Institute is gratefully acknowledged for providing met-ocean data at Karmøy (NO).

References

- [1] Vita L, Paulsen US, Pedersen TF, Madsen HA, Rasmussen F. (2009) A Novel Floating Offshore Wind turbine Concept. In Proceeding of European Wind Energy Conference (EWEC), Marseille, France.
- [2] Paulsen US, Madsen HA, Hattel JH, Baran I, Nielsen PH. (2013) Design Optimization of a 5 MW Floating Offshore Vertical-Axis Wind Turbine. *Energy Procedia* 35, 22 – 32.
- [3] Paulsen US, Madsen HA, Kragh KA, Nielsen PH, Baran I, Hattel JH, Ritchie E, Leban K, Svendsen HG, Berthelsen PA. (2014) DeepWind – from idea to 5MW concept. *Energy Procedia* 53, 23 – 33.
- [4] Paulsen US, Madsen HA, Hattel JH, Baran I, Nielsen PH. (2013) Design optimization of a 5 MW floating off shore vertical axis wind turbine. *Energy Procedia*, 35:22-32, 2013. ISSN 1876-6102.
- [5] Verelst D, Borg, M, Madsen, HA., Paulsen, US, Svendsen, HG, Berthelsen, PA. (2015) Integrated simulation challenges with the DeepWind floating vertical axis wind turbine concept. To be submitted in *Energy Procedia* 2015
- [6] Ragni D, Simão Ferreira CJ, Correale G. (2014) Experimental investigation of an optimized airfoil for vertical axis wind turbines. *Journal of Wind Energy*, DOI: 10.1002/we.1780
- [7] Simão Ferreira CJ, Geurs, B. (2014) Aerofoil optimization for vertical-axis wind turbines *Wind Energy*, DOI: 10.1002/we.1762
- [8] Leban KM. (2014) Design Tool for Direct Drive Wind Turbine Generators: Proposed solutions for direct drive Darrieus generators 20MW. Department of Energy Technology, Aalborg University. 183 p. Research › Ph.D. thesis
- [9] Bjerregaard H, Sloth K, Thygesen RK. (2013) Design of Active Electromagnetic Bearing for Darrieus Type Wind Turbines, , MSc thesis, Aalborg University, June 2013. Available on-line at Aalborg University Library.
- [10] Verelst D, Madsen, HA, Kragh KA, Belloni F. (2014) Detailed Load Analysis of the baseline 5MW DeepWind Concept. DTU Wind Energy E-0057
- [11] Paulsen US, Schløer S, Larsén X, Hahman A, Larsen S, Svenstrup O. (2014) Concept Specifications/Prerequisites for DeepWind DTU Wind Energy E0059(EN)
- [12] Myhr A, Bjerkseter C, Ågotnes A, Nygaard TA (2014) Levelised cost of energy for offshore floating wind turbines in a life cycle perspective *Elsevier Renewable energy* 66(2014)714-728
- [13] Kost C. (2013) Levelized Cost of Electricity Renewable Energy Technologies Study Fraunhofer ISE November 2013