

19



NL Octrooicentrum

11

2003940

12 C OCTROOI

21 Aanvraagnummer: 2003940

51 Int.Cl.:
B29C 70/38 (2006.01) B62D 23/00 (2006.01)
B62D 29/04 (2006.01)

22 Aanvraag ingediend: 10.12.2009

43 Aanvraag gepubliceerd:
-

73 Octrooihouder(s):
Delft University of Technology te Delft.

47 Octrooi verleend:
14.06.2011

72 Uitvinder(s):
Adriaan Beukers te Delft.
Otto Korneles Bergsma te Delft.
Sotiris Koussios te Delft.
Peter D'Haese te Delft.
Michael Rommens te Delft.

45 Octrooischrift uitgegeven:
22.06.2011

74 Gemachtigde:
Ir. H.Th. van den Heuvel c.s.
te 'S-HERTOGENBOSCH.

54 Method for producing a nodal frame of interconnected structural members and flexible elongated material structure for use in the method.

57 The invention relates to a method for producing a nodal frame of interconnected structural members, such as a car, the method comprising: providing a flexible elongated material structure; providing a mould that defines the shape of the frame and is adapted to support the flexible elongated material structure at least over those parts of the mould that correspond to the position of the structural members; positioning the material structure onto these parts of the mould a number of times to form the structural members; fixating at least part of the thus formed structural members and/or the nodes between structural members in order to stabilize the frame; and removing at least a part of the mould from the frame. The invention moreover relates to a flexible elongated material structure for use in the method.

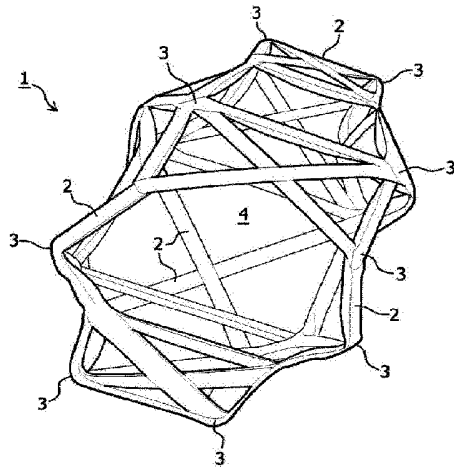

NL C 2003940

Dit octrooi is verleend ongeacht het bijgevoegde resultaat van het onderzoek naar de stand van de techniek en schriftelijke opinie. Het octrooischrift komt overeen met de oorspronkelijk ingediende stukken.

Method for producing a nodal frame of interconnected structural members and flexible elongated material structure for use in the method

The invention relates to a method for producing a nodal frame of interconnected
5 structural members and to a frame. The invention also relates to a flexible elongated material structure for use in the method, and to a transport means comprising the frame.

Many engineering structures, such as cars, motorbikes, boats and the like, comprise a
frame for taking up and distributing loads. Specific requirements, such as strength and
10 stiffness, influence the design of the frame. A particular design parameter is the applied load onto the frame. Examples of loads are the weight of a person supported by the frame, reaction forces from the driving of the car, e.g. from the engine, and other external loads, such as from irregularities in a road or a water surface and aerodynamic forces. These loads occur frequently, are typically lower than the ultimate strength of
15 the frame, but may lead to fatigue failure. Another example is impact, which may result in excessively high stresses which have to be picked up and distributed by the frame. Common frames are made from steel or aluminium bars, which are interconnected by mutually welding the bars. Although the known frames can be built in a strong and stiff manner, such frames are relatively heavy, may show dimensional inaccuracies and are
20 prone to fatigue. In certain applications there is a desire for providing a more lightweight frame, while maintaining stiffness and strength.

It is an object of the present invention to provide a method for producing a more
lightweight frame. It is a further object to provide a more lightweight nodal frame of
25 structural members.

According to the invention, one of the objects is achieved by a method for producing a nodal frame of interconnected structural members, such as the frame of a car, the method comprising: providing a flexible elongated material structure, providing a
30 mould that defines the shape of the frame and is adapted to support the flexible elongated material structure at least over those parts of the mould that correspond to the position of the structural members, positioning the material structure onto these parts of the mould a number of times to form the structural members, fixating at least part of the

thus formed structural members and/or the nodes between structural members in order to stabilize the frame and removing at least a part of the mould from the frame.

The method according to the invention allows to produce a frame of interconnected
5 members with specific mechanical properties wherein the mutual connection of the structural members is an integral part of the members. As a result, a lightweight frame can be obtained, wherein the mechanical requirements can be adjusted by either adjusting the number of structural members or by multiple positioning the material structure along the mould according to preferred structural members. Positioning the
10 elongated material structure over an already positioned material structure, wherein the elongated material structure makes an angle with the already positioned elongated material structure, may form the interconnections of the structural members. Another possibility is to position the material structure over and under an already positioned material structure, thereby forming a loop (partially) around the already positioned
15 material structure. The production method according to the invention also allows for automating the production process, e.g. by the use of a robot or a plurality of robots. Furthermore, as the structural members form integral parts, separate joining of the structural members is absent or at least decreased, damage as a result of fatigue at or near the connections of the structural members is decreased. The fixation of at least part
20 of the thus formed structural members and/or the nodes between structural members in order to stabilize the frame is preferably done by embedding at least those parts of the structural members which are to be fixated in a matrix and subsequently cure the matrix. Although curing of the matrix at room temperature and atmospheric pressure or vacuum is not excluded, the matrix is preferably cured by positioning the mould with the
25 material structure into an oven and cure the matrix material at a desired elevated temperature and under pressurized conditions for a desired period of time. This provides the frame with good dimensional accuracy, as the whole frame is positioned in the oven and not only parts of it and therefore undergoes substantially similar curing conditions.

30 With flexible elongated material structure is meant in the context of the present application a material structure that is substantially continuous, for instance is supplied on a roll, and may be bend easily enough to be able to position it onto various parts of a curved mould.

In a first embodiment the material structure has variable mechanical properties along its length. This improves flexibility in adjusting the mechanical properties of the structural members of the frame in relation to desired mechanical properties. As will become apparent herein below, the variable mechanical properties in certain sections of the material structure are preferably obtained by increased cross-sectional dimension(s) of these sections, thereby increasing the moment of inertia.

In a preferred embodiment the material structure is positioned onto those parts of the mould that correspond to the position of the structural members in a predetermined order. By predetermining the order of positioning the material structure along the mould, an improved frame can be obtained in terms of strength to weight ratio. An example of predetermining the positioning the material structure is to define the order in which the material structure is positioned along the frame to build the structural members. This allows for the possibility to decrease unnecessary positioning of material structure along the mould. Such unnecessary positioning may for example result from that forming a specific structural member requires positioning a material structure along a first position to reach a second position, along which first position already a material structure is positioned. By predetermining the path of the structural members along the frame, an improved path-sequence may be obtained, wherein the positioning of a material structure over already placed material structures may be prevented or at least decreased. It further provides the possibility to automate the method according to the invention. In this context it is advantageous if the order in which the material structure with variable mechanical properties is positioned onto those parts of the mould, that the desired mechanical properties of the material structure positioned along the mould correspond to the position of the structural members, such that the desired mechanical properties of the structural members are obtained. This may further improve the strength over weight ratio as well as the stiffness of the frame.

In a preferred embodiment of the method according to the invention, the desired mechanical properties of a member are obtained by positioning the material structure onto that part of the mould that corresponds to said member a number of times, thereby increasing the mechanical properties at each passage. This is an easy method of obtaining desired mechanical properties of the structural members and is particular

advantageous if the difference in preferred mechanical properties of the structural members is relatively large.

5 In yet another preferred embodiment, the desired mechanical properties of a member are obtained by positioning a material structure with varying mechanical properties along its length in such order that a section of the material structure with the desired mechanical properties is positioned onto that part of the mould that corresponds to said member. Using this preferred method allows for further improving the strength to weight ratio of the frame, as the variable mechanical properties along the length of the material structure are such that they correspond to the preferred mechanical properties of the structural members.

10 In a preferred embodiment the material structure is positioned onto the mould according to a particular routing that is defined by a sequence of positions on the mould, wherein a computer program determines the order for positioning the material structure by: assigning, for a first position on the mould, a penalty to possible second positions, calculating the sequence of positions with the lowest total penalty, and positioning the material structure according to the calculated sequence. This embodiment allows to produce the frame with improved mechanical properties in a reduced time period, as compared to state of the art methods, such as the method that involves assembling and connecting metal bars.

25 Another preferred embodiment of the method according to the invention is characterized in that the penalty for the possible second positions is updated each time the material structure has been positioned to a new first position. Since positioning the material structure at a first position changes the conditions for calculating the next position, the penalties should be updated. An example of such an update, is increasing the penalty for the first position where the material structure just is positioned, since it is not preferred to unnecessary position material structure along the first position repeatedly, unless the design requirements of the frame require that the material structure should be positioned at the first position at least one more time.

In yet another preferred embodiment those parts of the mould that correspond to the position of the structural members are defined by grooves in the mould. This allows for

unambiguously positioning the material structure onto the mould, according to the predetermined path. In case of manual positioning the material structure, human errors are decreased and/or it allows to automate the method according to the invention. This furthermore allows for positioning the material structure according to non-geodetic paths, thereby forming structural members according to the non-geodetic path, as the paths are determined by the grooves in the mould.

The material structure can be formed in various ways. The material structure can be made of isotropic material, such as a polymer or a metal strip. Preferably, the material structure comprises reinforcing fibres, optionally embedded in a matrix material, such as a polymer. Such a material structure combines good mechanical properties with a low weight and allow for easy varying the mechanical properties along the length of the material structure. Furthermore, such a material structure shows good fatigue properties. The reinforcing fibres may be of any material, including carbon or graphite and glass fibres. Other fibres to be suitably applied in the method according to the invention are drawn thermoplastic polymer fibres, comprising poly(p-phenylene-2, 6-benzobisoxazole) fibres (PBO, Zylon®), aramid fibres, and poly(2,6-diimidazo-(4,5b-4',5'e)pyridinylene-1,4(2,5-dihydroxy)phenylene) fibres (M5® fibres), or combinations thereof. The fibres may also be embedded in an uncured or partially cured matrix material, such as a polymer. According to the method of the invention, these so-called prepreg tapes are positioned onto the mould and fixated by heating for instance. The matrix material in the prepregs may serve as fixation means. It is also possible to locally heat (and therefore cure) the prepreg tapes to obtain the fixations at the heated locations.

Any matrix material known in the art may be used in the method of the invention. Examples of suitable matrix materials for the reinforcing elements include thermoplastic polymers such as polyamides, polyimides, polyethersulphones, polyetheretherketone, polyurethanes, polyethylene, polypropylene, polyphenylene sulphides (PPS), polyamide-imides, acrylonitrile butadiene styrene (ABS), styrene/maleic anhydride (SMA), polycarbonate, polyphenylene oxide blend (PPO), thermoplastic polyesters such as polyethylene terephthalate, polybutylene terephthalate, as well as mixtures and copolymers of one or more of the above polymers. Suitable matrix materials also comprise thermosetting polymers such as epoxies, unsaturated

polyester resins, melamine/formaldehyde resins, phenol/formaldehyde resins, polyurethanes, and the like.

5 Although a material structure with substantially parallel arranged strands and/or fibres are not excluded, the material structure preferably comprises a textile structure, such as a braid, in particular a hollow braid, a woven fabric, a yarn, a tape, and the like. This provides the material structure with a certain coherence, which allows for improved handling of the material structure during the production of the frame.

10 Another possibility is that the material structure has variable mechanical properties along its length, and that these varying mechanical properties are obtained by increasing the moment of inertia of the material structure. In this way the material structure may in particular be provided with a preferred bending stiffness. It may also be that the material structure has variable mechanical properties along its length in certain sections, and that
15 these varying mechanical properties are obtained by increasing the moment of inertia of the material structure in said sections. In this way, the said sections can be used to form preferred structural members.

20 There are many ways to increase the moment of inertia of the material structure. This may be done by increasing the cross-section of a massive material structure, which makes the material structure also less flexible and heavier. In a preferred embodiment the moment of inertia in the sections is increased by providing said sections with a hardening filling material, such as a foam. Using such a filling material provides the material structure with an increased moment of inertia, with only a minimal increase in
25 weight.

The invention also provides a frame, obtainable by the method according to the invention. Examples of frames include trusses used in the building industries, the furniture industries, the transport and aircraft industries, and the like. Further, the
30 invention provides a transport means, such as a car, comprising a frame according to the invention. The advantages of a frame obtained by the method according to the invention and a transport means comprising such a frame correspond to the advantages as described in relation to the method for producing such a frame.

Moreover the invention provides a material structure comprising at least two sections along its length having different mechanical properties. Such a material structure can, amongst other applications, be used for producing a frame according to the invention.

- 5 In an embodiment according to the invention, at least two sections of the elongated material structure comprise different materials. This allows to easy adjust the mechanical properties of the material structure.

10 In another embodiment, the at least two sections have different cross-sections. This provides the material structure with a varying moment of inertia along the length of the material structure and thereby with varying mechanical properties. A possible method of adjusting the cross-section is providing the material structure with a filling material, such as pressurized air.

- 15 In a preferred embodiment the material structure is a hollow textile structure, preferably a hollow braid. Textile structures allow for easy adjusting the mechanical properties along the length of the material structure. Preferred parameters include: the number of strands which forms the textile material structure, the thickness of the wires, rovings, filaments or strands and velocity of strand delivery relative to material structure
20 discharge, although other parameters are not excluded. Although a braid is preferred, the textile structure may also include a twisted cord, a woven fabric, a yarn, a tape, and the like.

25 In yet another embodiment, at least one section comprises an insert in the cavity of the hollow textile structure. Providing the material structure with inserts, such as rigid beam elements, with preferred varying cross-sections at preferred sections of the material structure, provides the material structure with a preferred moment of inertia. The beam elements may either have a constant or a varying cross-section along their length, which further increases the flexibility of adjusting the moment of inertia of the structural
30 members of the frame.

In another embodiment, the insert comprises a foamable substance. This may provide the material structure with an increased moment of inertia and thereby an increased stiffness with only a relative low increase of weight.

In yet a further embodiment the method comprises deforming the material structure for providing the material with variable mechanical properties along the length of the material structure. This is an easy method of varying the mechanical properties of the material structure along the length of the material structure. An example is to apply a tensile stress in length direction at preferred sections of the material structure, wherein the material structure elongates, thereby decreasing the bending stiffness and strength of the material structure. Such deformation also leads to a variable fibre orientation within the material structure, the fibres may for example be oriented in a more longitudinal direction of the elongated material structure, which variable fibre orientation leads to variable fibre orientation. Said method can be applied during forming of the material structure or in an additional step, after forming the material structure. In this embodiment, before deforming the material structure, the material structure may comprise substantially constant mechanical properties, but the material structure may also already comprise variable mechanical properties.

15

The invention will now be further elucidated with reference to the following schematic figures, without however being limited thereto.

Figure 1 schematically shows a perspective view of a frame according to the invention, Figure 2 schematically shows a perspective view of a mould for producing the frame according to the invention,

20

Figures 3A – 3E schematically show the steps of producing a frame according to the invention, and

25

Figure 4 schematically shows a perspective view of a material structure according to the invention.

With reference to figure 1 a space frame 1 according to the invention is shown. The frame 1 is produced using the method according to the invention and comprises a plurality of structural members 2, wherein all structural members 2 are made from a single elongated material structure. The material structure is a hollow braid with a closed cross-section made from carbon fibres, which, after, during or before positioning the material structure over the mould 1, is embedded in an epoxy-matrix and cured at elevated temperature and pressure. The structural members 2 are interconnected at their respective end-parts, forming connections 3. The connections 3 form the nodes of the

30

frame 1. The structural members 2 form a closed loop and enclose a space 4. The space frame 1 is dimensioned to be used in a car.

5 With reference to figure 2 a mould 10 for the production of the frame 1 of figure 1 is shown. The mould 10 may be made from any relatively rigid material, such as aluminium or steel, wood or foam, and is in this embodiment made of polyurethane foam. The mould 10 comprises grooves 11, which correspond with the structural members 2 of the frame 1 of figure 1. An advantage of the grooves 11 is that the material structure can unambiguously be positioned at a desired path, especially
10 according to a non-geodetic path.

The method for producing the frame 1 is explained according to figures 3A – 3E:
For the production of the frame 1 of figure 1, a mould 10 is provided (see figure 3A). In addition an elongated material structure 12, formed as a hollow braid made from carbon
15 fibres is provided (see figure 3B). The elongated material structure 12 is positioned along a predetermined path according to the grooves 11 of the mould 10 (figure 3B), until all structural members 2 of the frame 1 of figure 1 are formed (figure 3C). Subsequently, the material structure 12 positioned onto the frame 1 is embedded in an epoxy matrix and placed in an oven 13. In the oven 13 the material structure 12
20 embedded in an epoxy matrix is cured at elevated temperature and under pressurized conditions for a desired period of time (figure 3D). After curing the matrix material, the mould 10 is removed from the oven 13 and cooled, where after the frame 1 is removed out of the space enclosed by the frame 1 (figure 3E). Removing the mould 10 can be done by splitting the mould 10 in pieces, in case the mould 10 is made from a relatively
25 weak material such as a foam. Another option is to form the mould 10 as an assembly of a plurality of mould parts, which each can be removed out of the space 4. Yet another option is to split the material structure 12 at specific locations which allow for the removal of the mould 10 and subsequently reconnecting the splitted material structure 12.

30 With reference to figure 4 a section of a material structure 12 is shown. The material structure 12 is formed as a braid made from carbon fibres. The material structure 12 is filled with a polyurethane foam 14. The strands of the braided material structure 12 is tight, such that no or almost no foam will be pressed through the wall of the braided

material structure 12. After filling the material structure 12 with the polyurethane foam 14 the carbon fibres of the material structure 12 are embedded in an epoxy matrix and cured in an oven at elevated temperature and under pressurized conditions for a desired period of time.

Conclusies

1. Werkwijze voor het vervaardigen van een raamwerk uit onderling verbonden constructiedelen, zoals het raamwerk van een auto, omvattende:
 - 5 - het verschaffen van een flexibele langwerpige materiaalstructuur;
 - het verschaffen van een mal die de vorm van het raamwerk bepaalt en is ingericht om de flexibele langwerpige materiaalstructuur ten minste op die delen van de mal te ondersteunen die overeenstemmen met de positie van de constructiedelen;
 - 10 - het een aantal keer op deze delen van de mal positioneren van de materiaalstructuur om de constructiedelen te vormen;
 - het fixeren van ten minste een deel van de aldus gevormde constructiedelen en/of de knooppunten tussen constructiedelen om het raamwerk te stabiliseren; en
 - 15 - het ten minste gedeeltelijk verwijderen van de mal van het raamwerk.

2. Werkwijze volgens conclusie 1, **met het kenmerk** dat de materiaalstructuur variabele mechanische eigenschappen over zijn lengte heeft.

- 20 3. Werkwijze volgens conclusie 1 of 2, **met het kenmerk** dat de materiaalstructuur in een vooraf bepaalde volgorde op de met de positie van de constructiedelen overeenstemmende delen van de mal wordt gepositioneerd.

4. Werkwijze volgens conclusie 3, **met het kenmerk** dat de volgorde waarin de
25 materiaalstructuur op de met de positie van de constructiedelen overeenstemmende delen van de mal wordt gepositioneerd zodanig is gekozen dat de gewenste mechanische eigenschappen van de constructiedelen worden verkregen.

5. Werkwijze volgens conclusie 4, **met het kenmerk** dat de gewenste mechanische
30 eigenschappen van een constructiedeel worden verkregen door het een aantal keer op het met dat constructiedeel overeenstemmende deel van de mal positioneren van de materiaalstructuur, waarbij tijdens elke doorgang de mechanische eigenschappen worden verhoogd.

6. Werkwijze volgens conclusie 4 of 5, **met het kenmerk** dat de gewenste mechanische eigenschappen van een constructiedeel worden verkregen door het positioneren van een materiaalstructuur met variabele mechanische eigenschappen over zijn lengte in een zodanige volgorde dat een deel van de materiaalstructuur met de gewenste mechanische eigenschappen wordt gepositioneerd op het met dat constructiedeel overeenstemmende deel van de mal.
7. Werkwijze volgens een der conclusies 3 - 6, **met het kenmerk** dat de materiaalstructuur op de mal wordt gepositioneerd volgens een specifieke route die bepaald wordt door een volgorde van posities op de mal, waarbij een computerprogramma de volgorde voor het positioneren van de materiaalstructuur bepaalt door:
- het voor een eerste positie op de mal toewijzen van een waarde aan mogelijke tweede posities;
 - het berekenen van de volgorde van posities met de laagste totale waarde; en
 - het volgens de berekende volgorde positioneren van de materiaalstructuur.
8. Werkwijze volgens een der voorgaande conclusies, **met het kenmerk** dat de met de positie van de constructiedelen overeenstemmende delen van de mal worden gedefinieerd door groeven in de mal.
9. Werkwijze volgens een der voorgaande conclusies, **met het kenmerk** dat de materiaalstructuur versterkende vezels omvat, optioneel ingebed in een matrix materiaal, zoals een polymeer.
10. Werkwijze volgens conclusie 9, **met het kenmerk** dat de materiaalstructuur een textielstructuur omvat, zoals een vlecht, een weefsel, een garen, een band, en dergelijke meer.
11. Werkwijze volgens conclusie 10, **met het kenmerk** dat de materiaalstructuur variabele mechanische eigenschappen over zijn lengte heeft en dat deze variabele mechanische eigenschappen worden verkregen door het vergroten van het traagheidsmoment van de materiaalstructuur.

12. Werkwijze volgens conclusie 11, **met het kenmerk** dat de materiaalstructuur variabele mechanische eigenschappen over bepaalde delen van zijn lengte heeft en dat deze variabele mechanische eigenschappen worden verkregen door het vergroten van het traagheidsmoment van de materiaalstructuur in deze delen.
- 5
13. Werkwijze volgens conclusie 12, **met het kenmerk** dat het traagheidsmoment in de delen wordt vergroot door deze delen te voorzien van verhardend vulmateriaal, zoals perslucht, een schuim of een inzetstuk.
- 10
14. Raamwerk, verkrijgbaar met een werkwijze volgens een der voorgaande conclusies 1–13.
- 15.
15. Transportmiddel, zoals een auto, omvattende een raamwerk volgens conclusie 14.
- 15
16. Langwerpige materiaalstructuur, omvattende ten minste twee delen over zijn lengte met verschillende mechanische eigenschappen.
17. Langwerpige materiaalstructuur volgens conclusie 16, waarbij de ten minste
- 20 twee delen verschillende materialen omvatten.
18. Langwerpige materiaalstructuur volgens conclusie 16 of 17, waarbij de ten minste twee delen verschillende doorsneden hebben.
- 25
19. Langwerpige materiaalstructuur volgens een der conclusies 16-18, waarbij de materiaalstructuur een holle textielstructuur is, bij voorkeur een holle vlecht.
20. Langwerpige materiaalstructuur volgens conclusie 19, waarbij ten minste één deel een inzetstuk omvat in de holte van de holle textielstructuur.
- 30
21. Langwerpige materiaalstructuur volgens conclusie 20, waarbij het inzetstuk een opschuimbare substantie omvat.

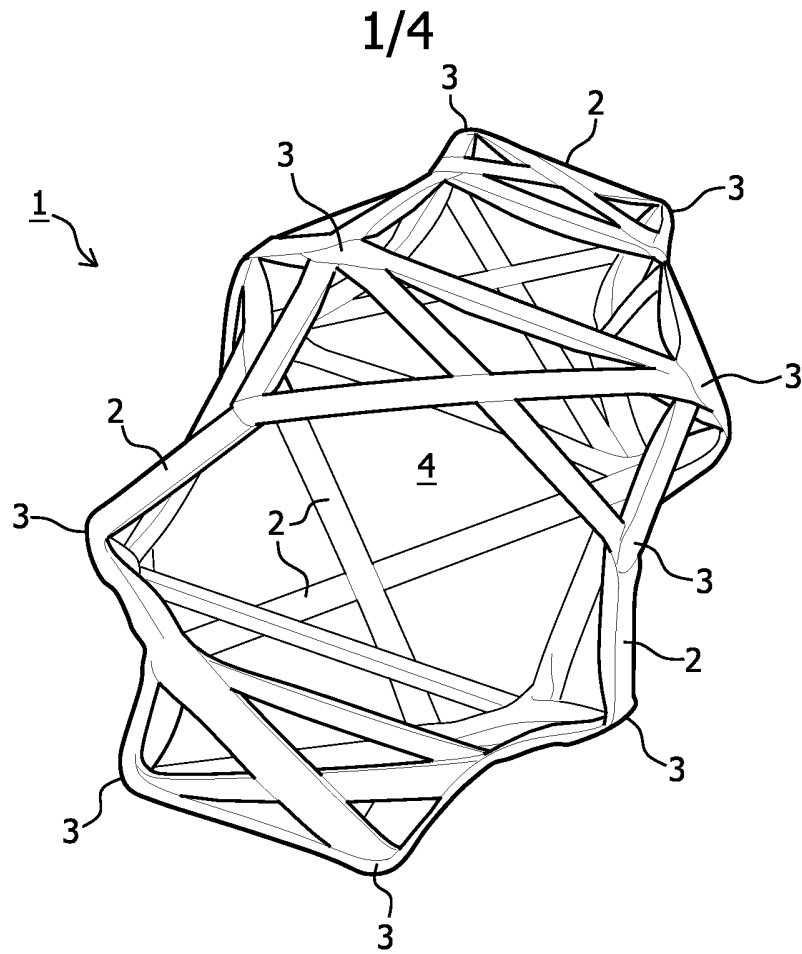

FIG. 1

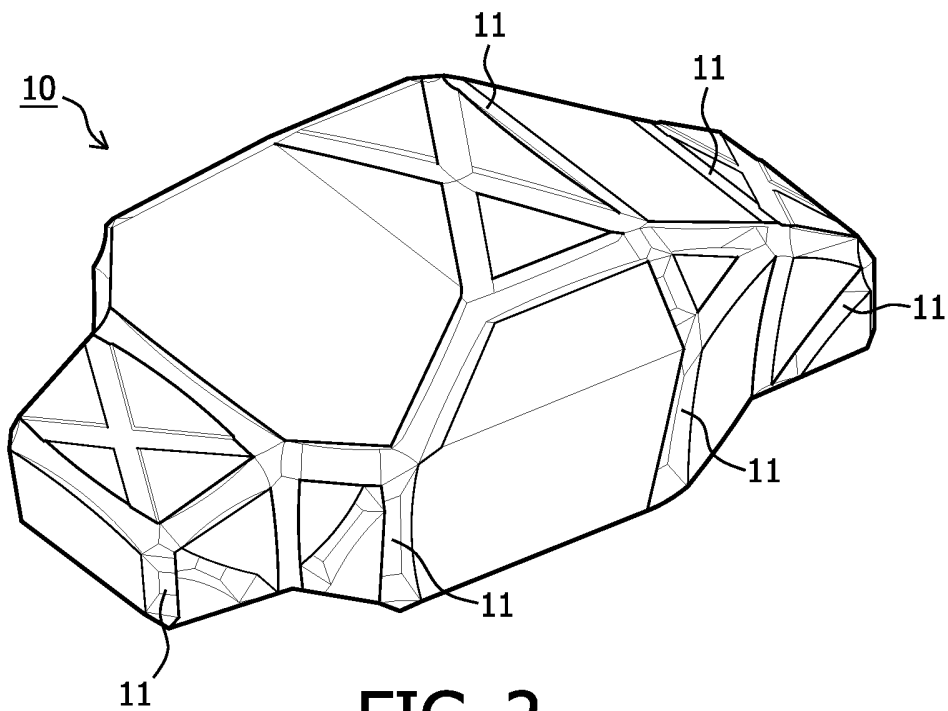

FIG. 2

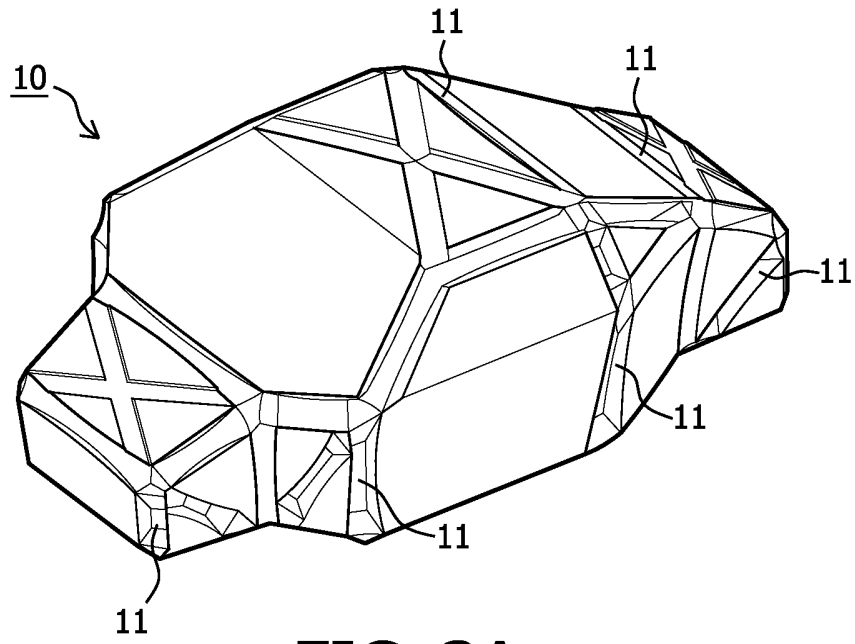

FIG. 3A

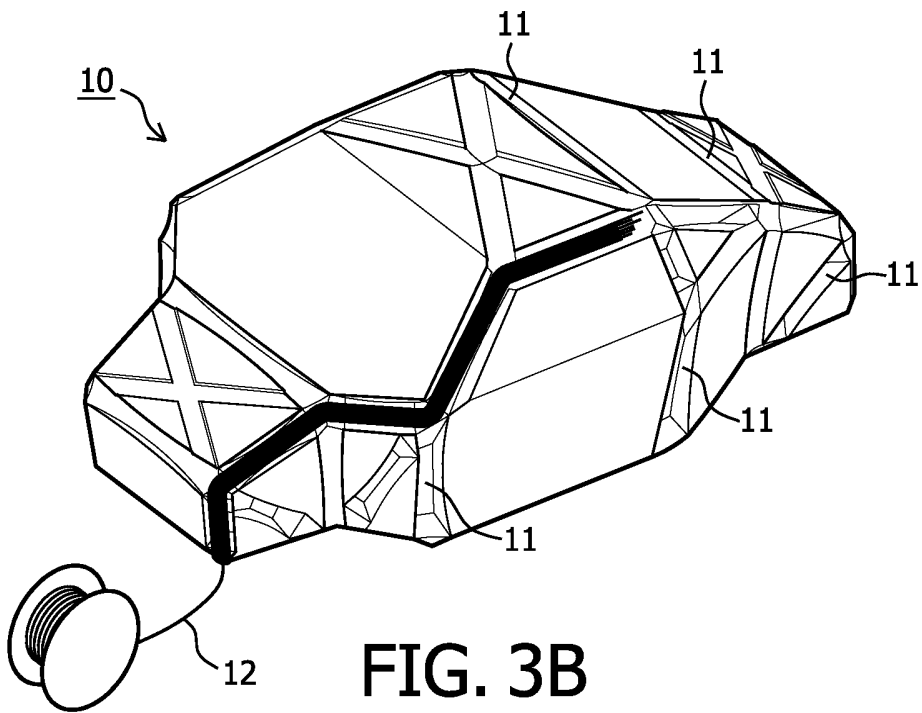

FIG. 3B

3/4

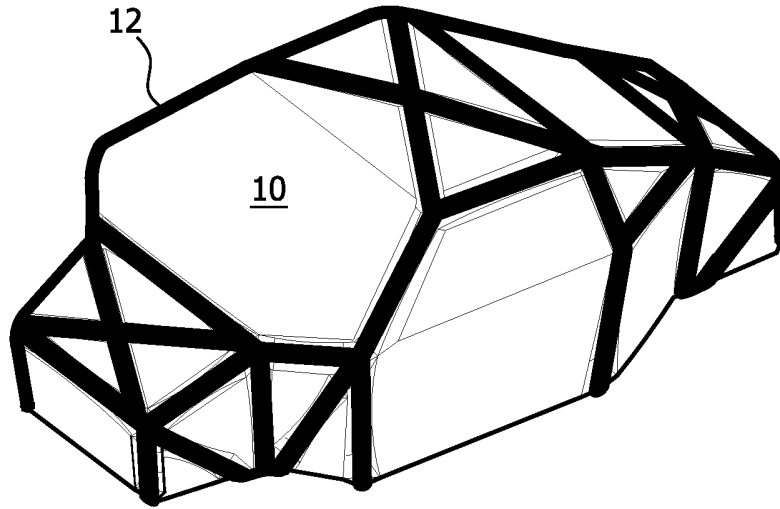

FIG. 3C

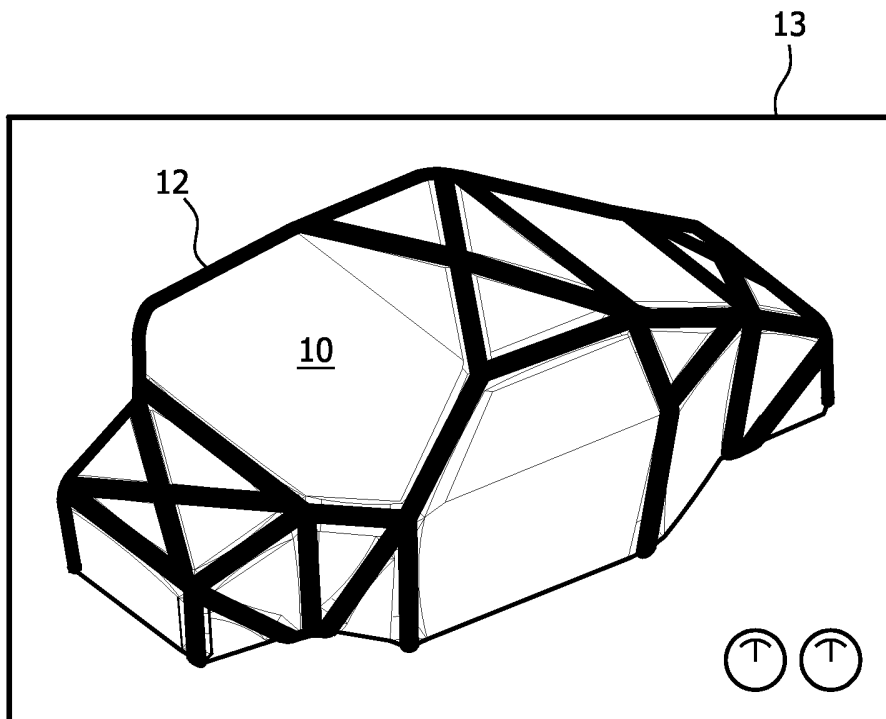

FIG. 3D

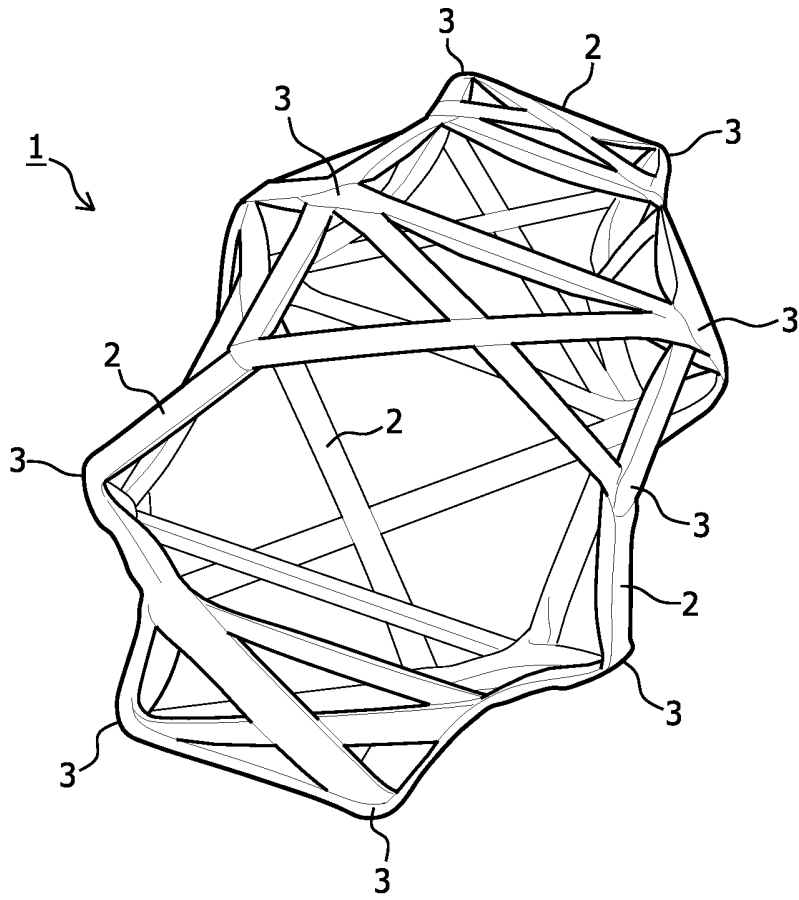

FIG. 3E

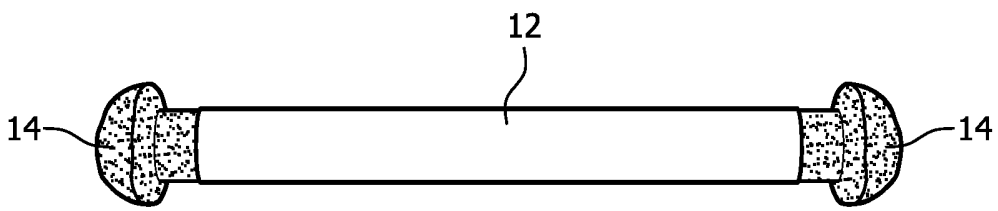

FIG. 4

SAMENWERKINGSVERDRAG (PCT)

RAPPORT BETREFFENDE NIEUWHEIDSONDERZOEK VAN INTERNATIONAAL TYPE

| | | |
|---|--|----------------------------------|
| IDENTIFICATIE VAN DE NATIONALE AANVRAGE | KENMERK VAN DE AANVRAGER OF VAN DE GEMACHTIGDE | |
| | 1.525.008 NL | |
| Nederlands aanvraag nr. | Indieningsdatum | |
| 2003940 | 10-12-2009 | |
| | Ingeroepen voorrangsdatum | |
| Aanvrager (Naam) | | |
| DELFT UNIVERSITY OF TECHNOLOGY | | |
| Datum van het verzoek voor een onderzoek van internationaal type | Door de Instantie voor Internationaal Onderzoek aan het verzoek voor een onderzoek van internationaal type toegekend nr. | |
| 16-03-2010 | SN 53830 | |
| I. CLASSIFICATIE VAN HET ONDERWERP (bij toepassing van verschillende classificaties, alle classificatiesymbolen opgeven) | | |
| Volgens de internationale classificatie (IPC) | | |
| B29C70/38 B62D23/00 B62D29/04 | | |
| II. ONDERZOCHE GEBIEDEN VAN DE TECHNIEK | | |
| Onderzochte minimumdocumentatie | | |
| Classificatiesysteem | Classificatiesymbolen | |
| IPC8 | B29C B62D | |
| Onderzochte andere documentatie dan de minimum documentatie, voor zover dergelijke documenten in de onderzochte gebieden zijn opgenomen | | |
| | | |
| III. | <input type="checkbox"/> GEEN ONDERZOEK MOGELIJK VOOR BEPAALDE CONCLUSIES | (opmerkingen op aanvullingsblad) |
| IV. | <input type="checkbox"/> GEBREK AAN EENHEID VAN UITVINDING | (opmerkingen op aanvullingsblad) |

**ONDERZOEKSRAPPORT BETREFFENDE HET
RESULTAAT VAN HET ONDERZOEK NAAR DE STAND
VAN DE TECHNIEK VAN HET INTERNATIONALE TYPE**

Nummer van het verzoek om een onderzoek naar
de stand van de techniek
NL 2003940

| | | |
|--|--|---|
| <p>A. CLASSIFICATIE VAN HET ONDERWERP INV. B29C70/38 B62D23/00 B62D29/04 ADD.</p> | | |
| <p>Volgens de Internationale Classificatie van octrooien (IPC) of zowel volgens de nationale classificatie als volgens de IPC.</p> | | |
| <p>B. ONDERZOCHE GEBIEDEN VAN DE TECHNIEK</p> | | |
| <p>Onderzochte minimum documentatie (classificatie gevolgd door classificatiesymbolen) B29C B62D</p> | | |
| <p>Onderzochte andere documentatie dan de minimum documentatie, voor dergelijke documenten, voor zover dergelijke documenten in de onderzochte gebieden zijn opgenomen</p> | | |
| <p>Tijdens het onderzoek geraadpleegde elektronische gegevensbestanden (naam van de gegevensbestanden en, waar uitvoerbaar, gebruikte trefwoorden) EPO-Internal</p> | | |
| <p>C. VAN BELANG GEACHTE DOCUMENTEN</p> | | |
| <p>Categorie °</p> | <p>Geciteerde documenten, eventueel met aanduiding van speciaal van belang zijnde passages</p> | <p>Van belang voor conclusie nr.</p> |
| <p>X</p> | <p>EP 1 495 856 A1 (CORETEX STRUCTURES LTD [GB]) 12 januari 2005 (2005-01-12) * alineas [0001], [0007], [0008], [0011], [0014], [0016], [0018], [0019], [0021], [0022], [0023], [0027], [0030], [0031], [0032], [0035] * * figuren 1,2,8,9,10 *</p> | <p>1-21</p> |
| <p>E</p> | <p>WO 2009/149778 A1 (DAIMLER CHRYSLER AG [DE]; ILZHOEFER KARL-HEINZ [DE]; SALKIC ASMIR [DE]) 17 december 2009 (2009-12-17) * bladzijden 1-7,9; figuur 3 *</p> | <p>14,15</p> |
| <p><input type="checkbox"/> Verdere documenten worden vermeld in het vervolg van vak C. <input checked="" type="checkbox"/> Leden van dezelfde octrooifamilie zijn vermeld in een bijlage</p> | | |
| <p>° Speciale categorieën van aangehaalde documenten</p> <p>"A" niet tot de categorie X of Y behorende literatuur die de stand van de techniek beschrijft</p> <p>"D" in de octrooiaanvraag vermeld</p> <p>"E" eerdere octrooi(aanvraag), gepubliceerd op of na de indieningsdatum, waarin dezelfde uitvinding wordt beschreven</p> <p>"L" om andere redenen vermelde literatuur</p> <p>"O" niet-schriftelijke stand van de techniek</p> <p>"P" tussen de voorrangsdatum en de indieningsdatum gepubliceerde literatuur</p> <p>"T" na de indieningsdatum of de voorrangsdatum gepubliceerde literatuur die niet bezwarend is voor de octrooiaanvraag, maar wordt vermeld ter verheldering van de theorie of het principe dat ten grondslag ligt aan de uitvinding</p> <p>"X" de conclusie wordt als niet nieuw of niet inventief beschouwd ten opzichte van deze literatuur</p> <p>"Y" de conclusie wordt als niet inventief beschouwd ten opzichte van de combinatie van deze literatuur met andere geciteerde literatuur van dezelfde categorie, waarbij de combinatie voor de vakman voor de hand liggend wordt geacht</p> <p>"&" lid van dezelfde octrooifamilie of overeenkomstige octrooipublicatie</p> | | |
| <p>Datum waarop het onderzoek naar de stand van de techniek van internationaal type werd voltooid</p> <p>20 juli 2010</p> | | <p>Verzenddatum van het rapport van het onderzoek naar de stand van de techniek van internationaal type</p> |
| <p>Naam en adres van de instantie</p> <p>European Patent Office, P.B. 5818 Patentlaan 2 NL - 2280 HV Rijswijk Tel. (+31-70) 340-2040, Fax: (+31-70) 340-3016</p> | | <p>De bevoegde ambtenaar</p> <p>Jouannon, Fabien</p> |

**ONDERZOEKSRAPPORT BETREFFENDE HET
RESULTAAT VAN HET ONDERZOEK NAAR DE STAND
VAN DE TECHNIEK VAN HET INTERNATIONALE TYPE**
Informatie over leden van dezelfde octrooifamilie

Nummer van het verzoek om een onderzoek naar
de stand van de techniek
NL 2003940

| In het rapport genoemd octrooigeschrift | Datum van publicatie | Overeenkomend(e) geschrift(en) | Datum van publicatie |
|--|-------------------------|-----------------------------------|-------------------------|
| EP 1495856 | A1 | 12-01-2005 GEEN | |
| WO 2009149778 | A1 | 17-12-2009 DE 102008027429 A1 | 17-12-2009 |



| | | | |
|---|---|---|------------------------------|
| File No. SN53830 | Filing date (<i>day/month/year</i>) 10.12.2009 | Priority date (<i>day/month/year</i>) | Application No. NL2003940 |
| International Patent Classification (IPC) INV. B29C70/38 B62D23/00 B62D29/04 | | | |
| Applicant Delft University of Technology | | | |

This opinion contains indications relating to the following items:

- Box No. I Basis of the opinion
- Box No. II Priority
- Box No. III Non-establishment of opinion with regard to novelty, inventive step and industrial applicability
- Box No. IV Lack of unity of invention
- Box No. V Reasoned statement with regard to novelty, inventive step or industrial applicability; citations and explanations supporting such statement
- Box No. VI Certain documents cited
- Box No. VII Certain defects in the application
- Box No. VIII Certain observations on the application

| | |
|--|------------------------------|
| | Examiner Jouannon, Fabien |
|--|------------------------------|

WRITTEN OPINION

Application number
NL2003940

Box No. I Basis of this opinion

1. This opinion has been established on the basis of the latest set of claims filed before the start of the search.
2. With regard to any **nucleotide and/or amino acid sequence** disclosed in the application and necessary to the claimed invention, this opinion has been established on the basis of:
 - a. type of material:
 - a sequence listing
 - table(s) related to the sequence listing
 - b. format of material:
 - on paper
 - in electronic form
 - c. time of filing/furnishing:
 - contained in the application as filed.
 - filed together with the application in electronic form.
 - furnished subsequently for the purposes of search.
3. In addition, in the case that more than one version or copy of a sequence listing and/or table relating thereto has been filed or furnished, the required statements that the information in the subsequent or additional copies is identical to that in the application as filed or does not go beyond the application as filed, as appropriate, were furnished.
4. Additional comments:

Box II Priority

This opinion has been established as if the claimed priority date were valid, unless indicated otherwise on the **separate sheet**

WRITTEN OPINION

Application number
NL2003940

Box No. V Reasoned statement with regard to novelty, inventive step or industrial applicability; citations and explanations supporting such statement

1. Statement

| | | |
|--------------------------|-------------|-----------|
| Novelty | Yes: Claims | 7 |
| | No: Claims | 1-6, 8-21 |
| Inventive step | Yes: Claims | |
| | No: Claims | 1-21 |
| Industrial applicability | Yes: Claims | 1-21 |
| | No: Claims | |

2. Citations and explanations

see separate sheet

Box No. VI Certain documents cited

Certain published documents

see the Search Report

Non-written disclosures

Box No. VII Certain defects in the application

see separate sheet

Box No. VIII Certain observations on the application

see separate sheet

Re Item V

Reasoned statement with regard to novelty, inventive step or industrial applicability; citations and explanations supporting such statement

- D1 EP 1 495 856 A1 (CORETEX STRUCTURES LTD [GB]) 12 januari 2005
(2005-01-12)
- 1 The present application does not meet the criteria of patentability, because the subject-matter of claims 1, 14 and 16 is not new.
- 1.1 A product claim (claim 14) defined by the process is allowable only if the product, per se, satisfy to the requirements of patentability. This is not the case in the present application as document D1 discloses a nodal frame of interconnected members (figure 1).
- 1.2 Document D1 discloses a method for producing a nodal frame of interconnected structural members (figure 1), such as the frame of a car, the method comprising:
- providing a flexible elongated material structure (paragraph 0014);
 - providing a mould that defines the shape of the frame and is adapted to support the flexible elongated material structure at least over those parts of the mould that correspond to the position of the structural members (paragraphs 0022 and 0023 and figure 2);
 - positioning the material structure onto these parts of the mould a number of times to form the structural members (paragraphs 0030 and 0031 and figure 10);
 - fixating at least part of the thus formed structural members and/or the nodes between structural members in order to stabilize the frame (paragraph 0023); and
 - removing at least a part of the mould from the frame (paragraph 0023).
- 1.3 Document D1 discloses an elongated material structure (figure 1) comprising at least two sections along its length having different mechanical properties (paragraph 0031).
- 2 Dependent claims 2 to 13, 15 and 17 to 21 do not contain any features which, in combination with the features of any claim to which they refer, meet the requirements of novelty and/or inventive step, see document and references applying to this document cited in the search report.

Re Item VI

Certain documents cited

| Application No Patent No | Publication date (day/month/year) | Filing date (day/month/year) | Priority date (valid claim) (day/month/year) |
|-----------------------------|--------------------------------------|---------------------------------|---|
| WO 2009/149778 | 17.12.2009 | 13.03.2009 | 09.06.2008 |

Re Item VII

Certain defects in the application

- 1 The relevant background art disclosed in document D1 is not mentioned in the description, nor is this document identified therein.
- 2 The features of the claims are not provided with reference signs placed in parentheses.

Re Item VIII

Certain observations on the application

Claim 2 does not meet the requirement of clarity because the matter for which protection is sought is not clearly defined. The claim attempts to define the subject-matter in terms of the result to be achieved, which merely amounts to a statement of the underlying problem, without providing the technical features necessary for achieving this result.