

# GAUDIUM

Joost Josse  
The Netherlands

## “De draad weer oppakken”

Gaudium is a textile production firm, situated in the industrial urban fabric of Winterswijk, using a building ensemble which is owned by the municipality. Since Gaudium's foundation it worked together with Kvadrat, which holds today the leading position in Europe's textiles market. The long-standing partnership between them is set to grow even closer. Kvadrat announced that its stake in the company will increase from 10% to 87%. However, the current state of the building complexes of Gaudium cannot answer this need. Thus there might be a major chance that the Danish textile company decides to continue with Gaudium elsewhere. Consequently, Winterswijk could lose a part of its identity. The craft of weaving played a role since the initiation of the settlement. Therefore, the aim of this design is to convince all of the interested parties that only this place has the potentials for a future perspective.

Gaudium is the urban transition between the town centre and the hinterland, located in an pedestrian environment. Hence, it could make more use of this favourable position, aiming for the weaving firm to open up and reveal what is happening inside, connecting with the inhabitants and green structures of the surrounding. Introducing a green corridor with several points of interest where the public meet the craft of weaving. Following the needs of Kvadrat, the production line of Gaudium has been enlarged as well. Moreover, a working and learning environment is added to enhance a future perspective. Besides that a shared canteen is introduced where the public, students and employees could come together. Eventually an integrated whole is created whereby different functions are interwoven with one another and the production shakes hands with the public. It is only a matter of 'De draad weer oppakken'.

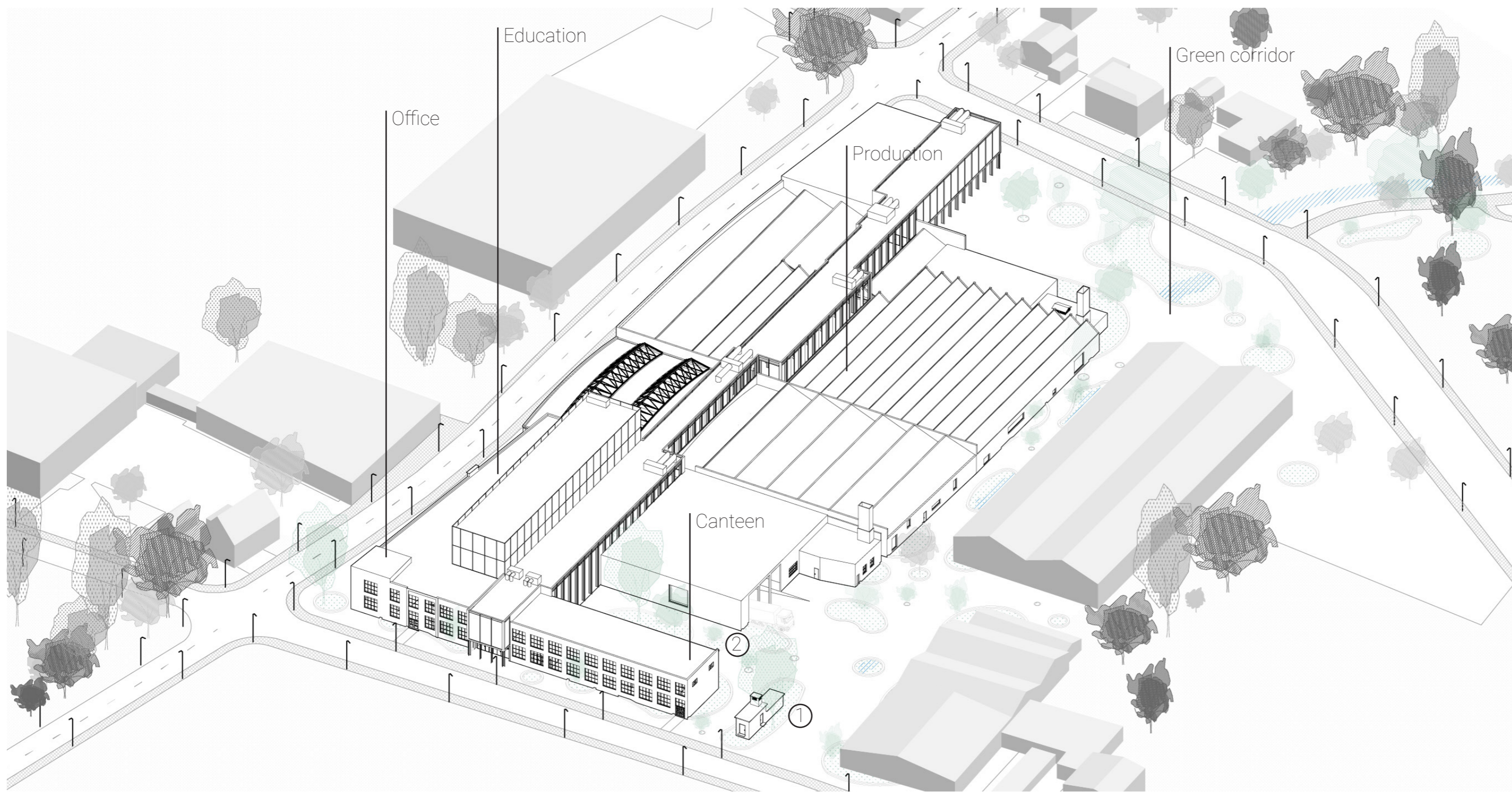

Masterplan 1.500



Membrane, a smooth transitional area



Green corridor, connecting with the surrounding



1. Impression green corridor



2. Impression shared canteen



# GAUDIUM

Joost Josse  
The Netherlands

“De draad weer oppakken”

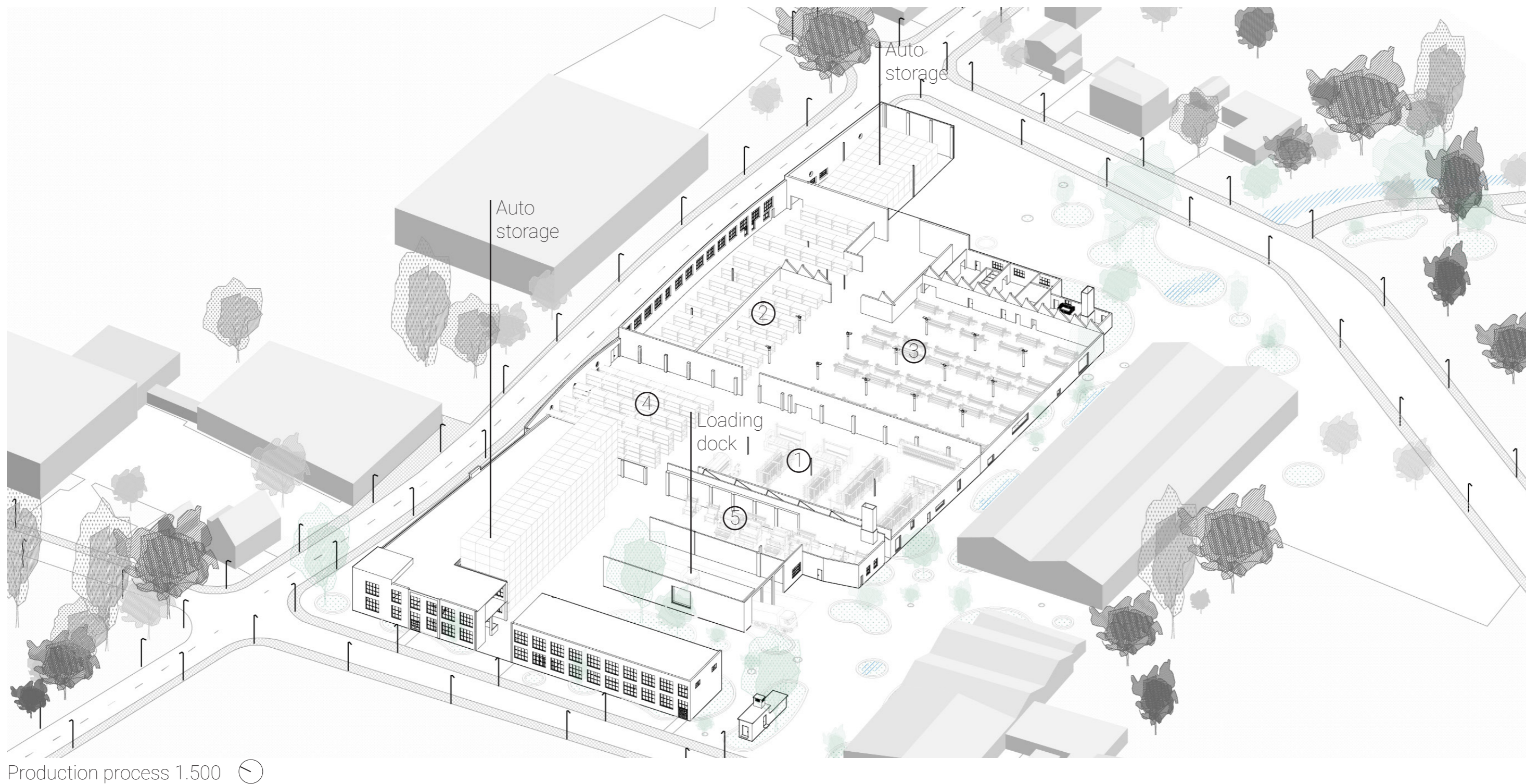

Production process 1.500

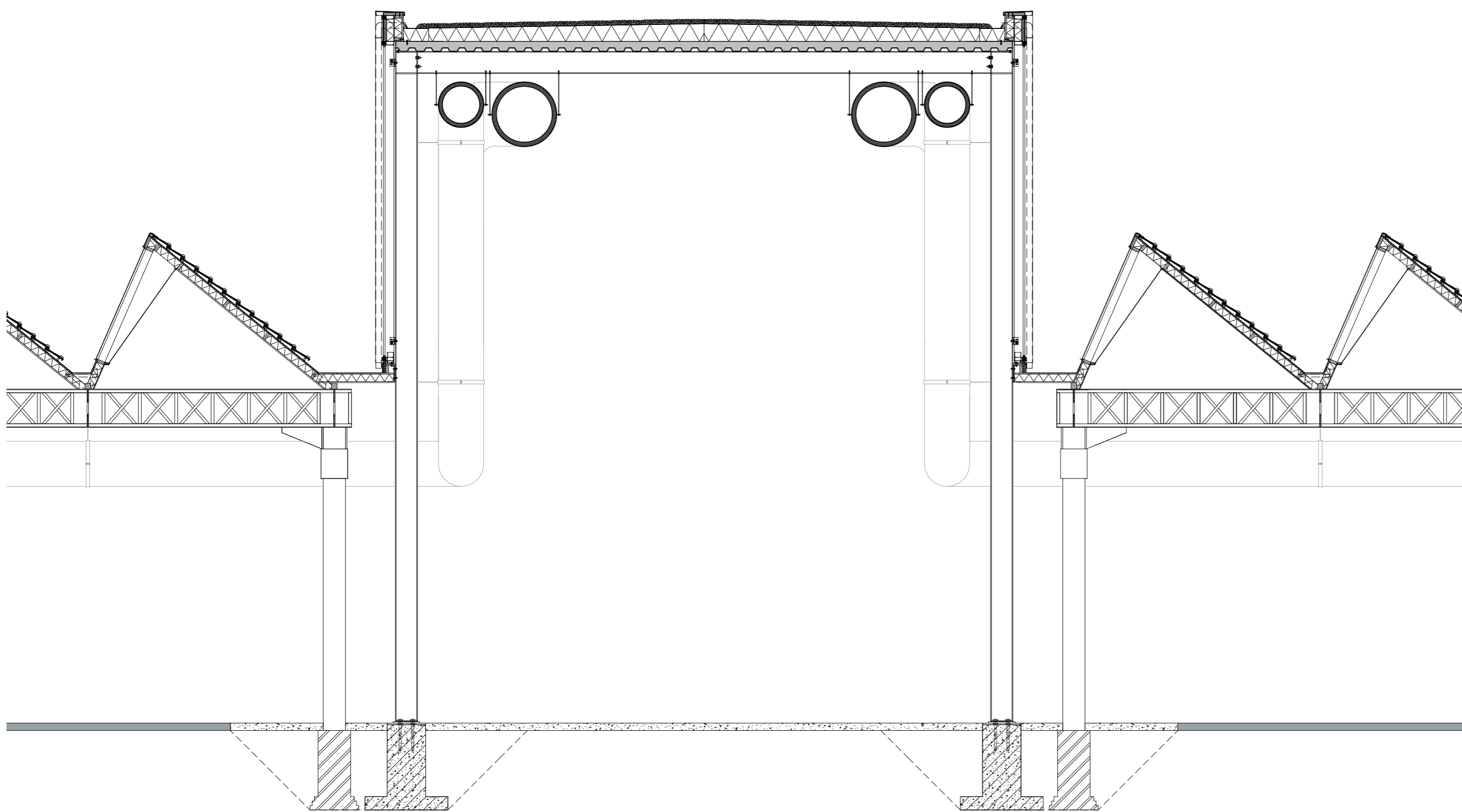
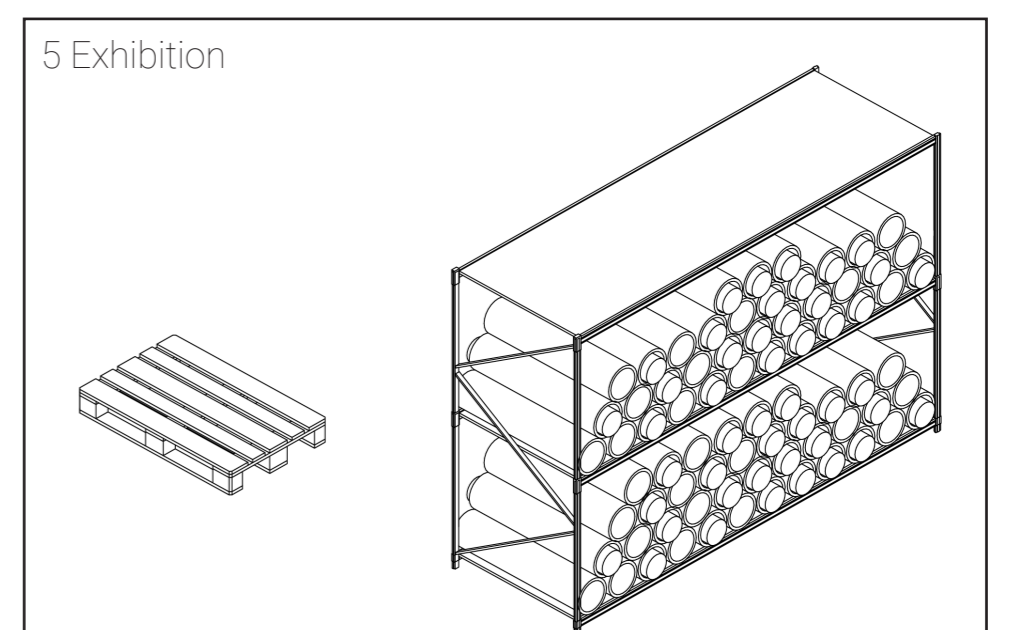
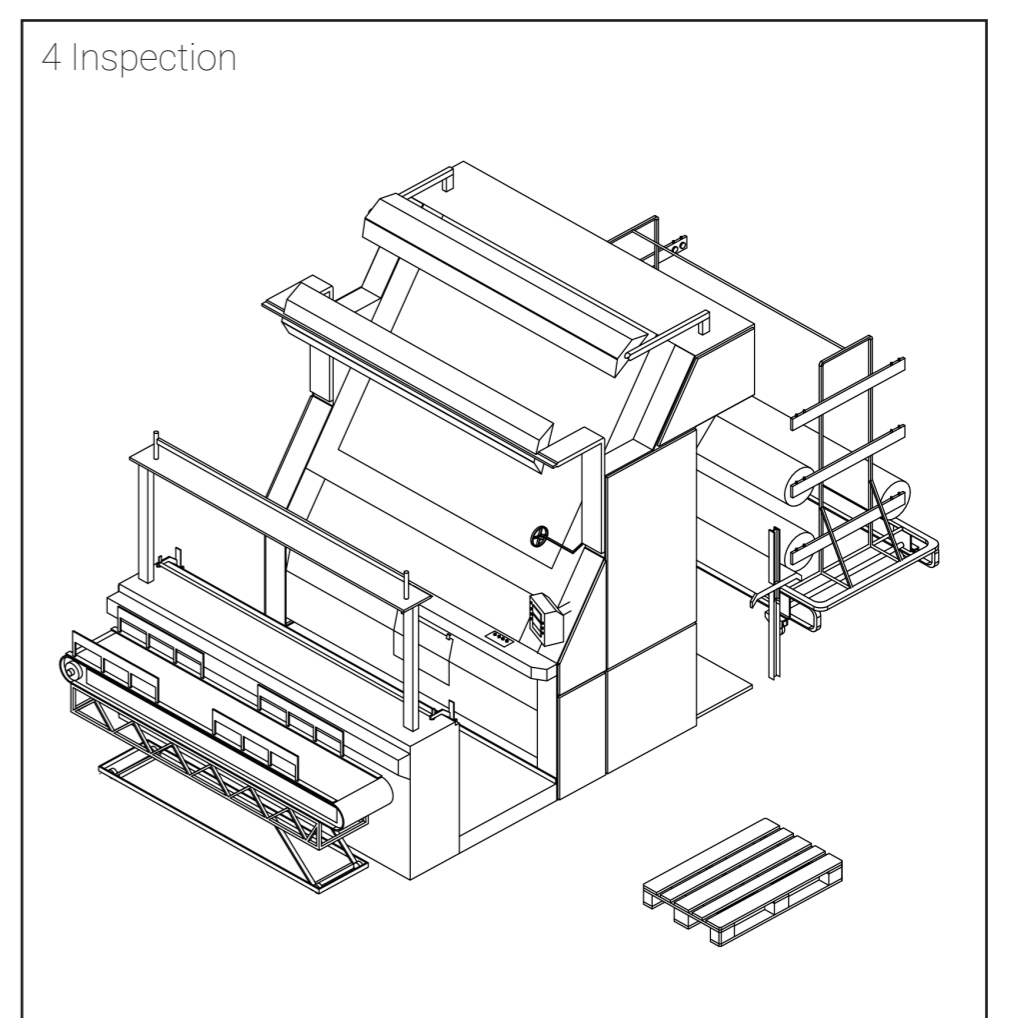
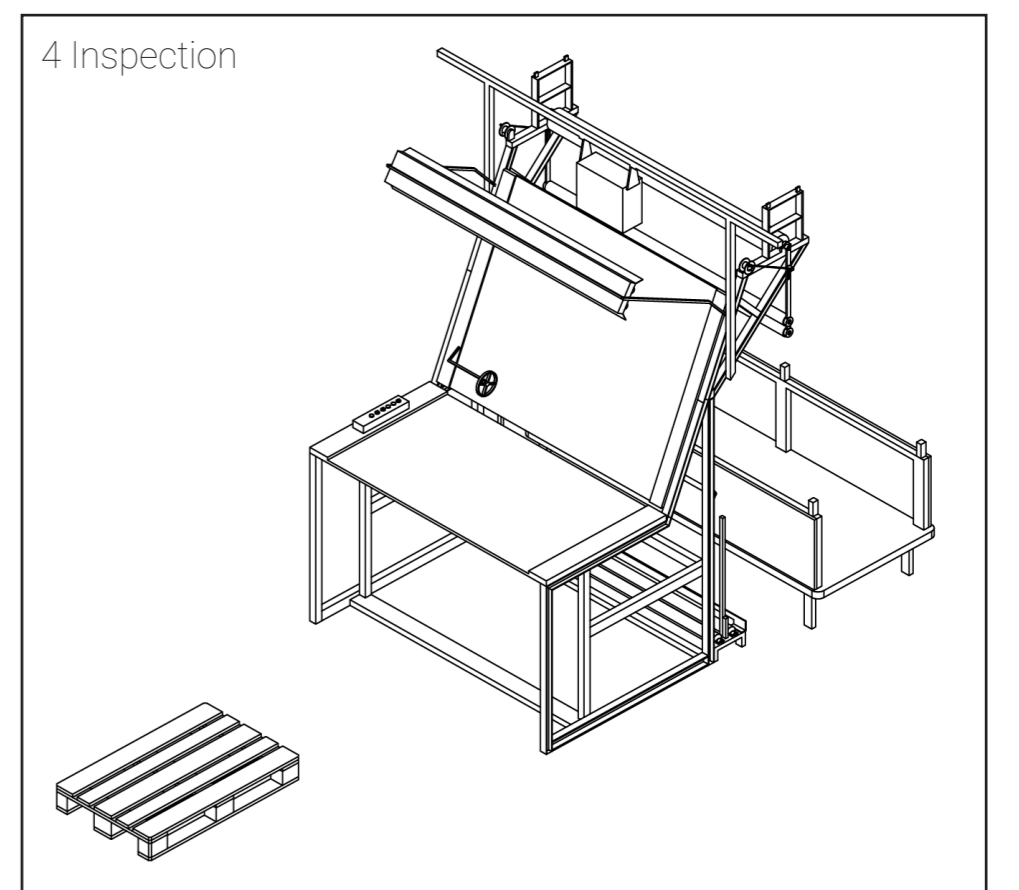
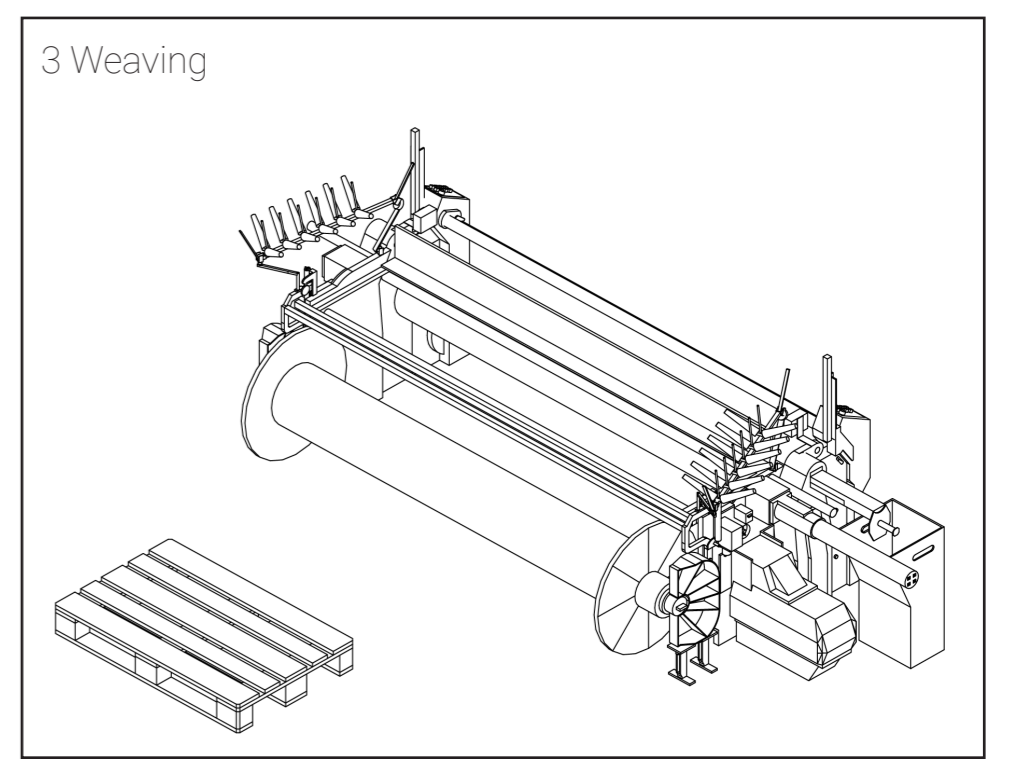
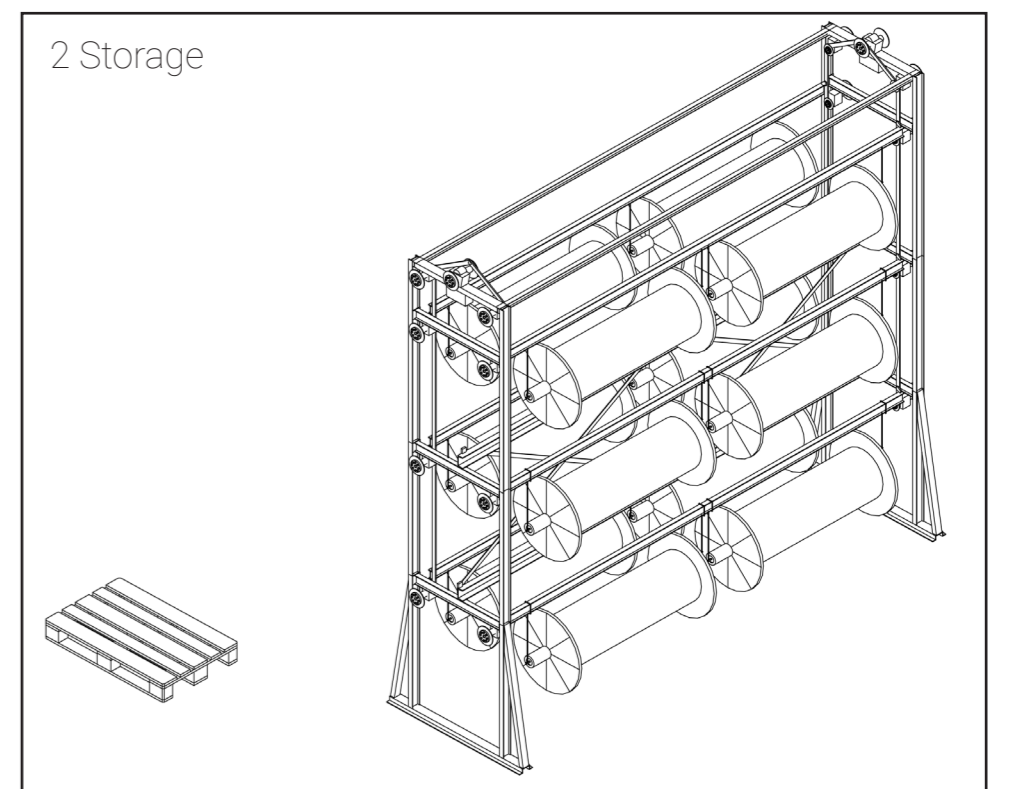
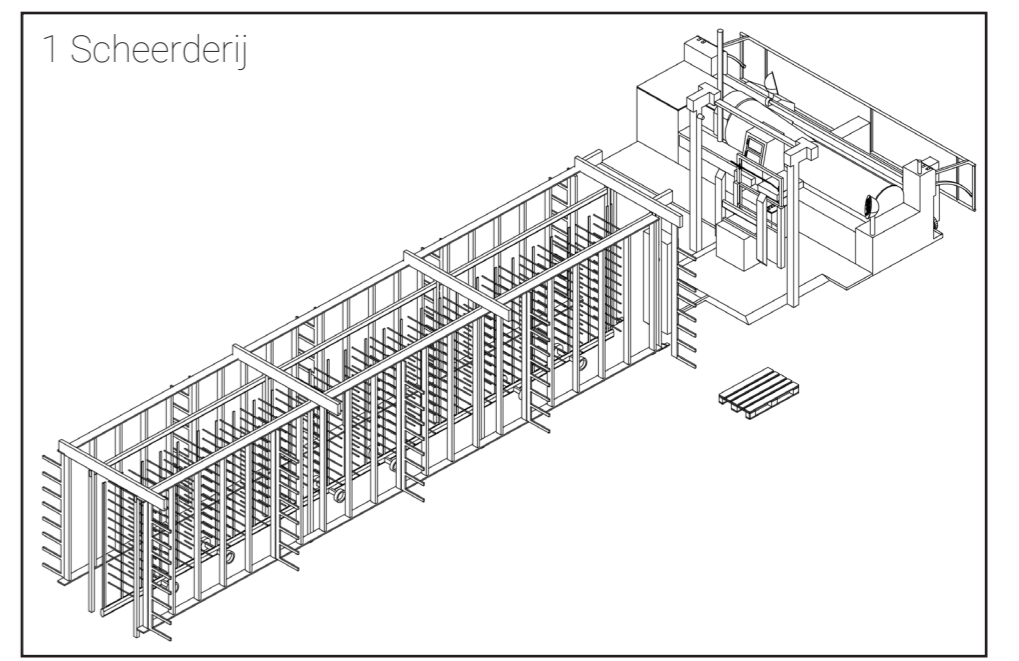

Section intervention with old core 1.20



Impression intervention with old core