

Van Gendt redeveloping industry



P4

Industrieel erfgoed in het centrum van Amsterdam

Inhoud

Introductie

Uitgangspunten

Reflectie P2

Ontwerp

Ambitie



Herontwikkeling industrieel erfgoed



RDM Werven, Rotterdam



ROC Twente, Hengelo



De Hallen Amsterdam

Kenmerken

- Huisvesting van productie proces
- Pragmatische bouw
- Aangepast naar behoefte

Industrie en de stad

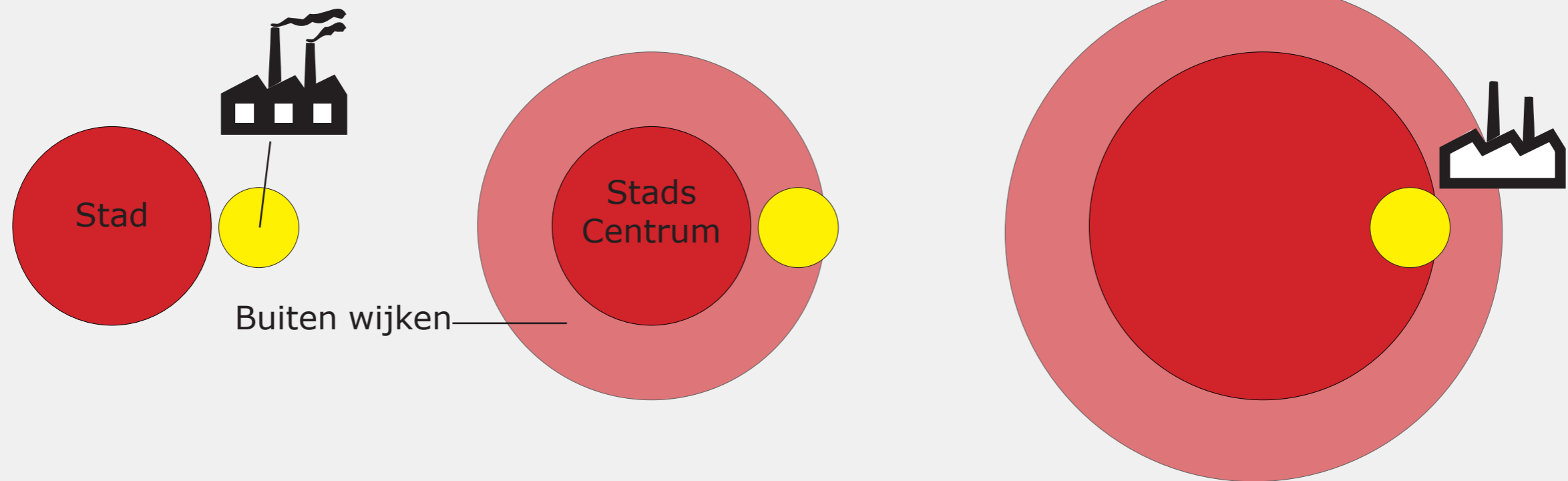

Potentie voor herontwikkeling



Groei

Symbiose Industrie en Stad



Leeg stand

Verdringing industrie

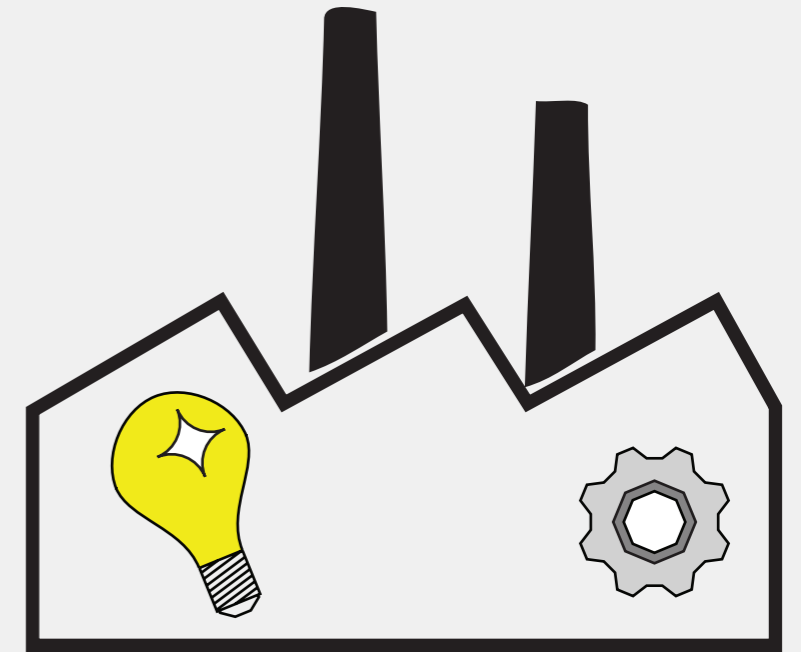

Herontwikkeling

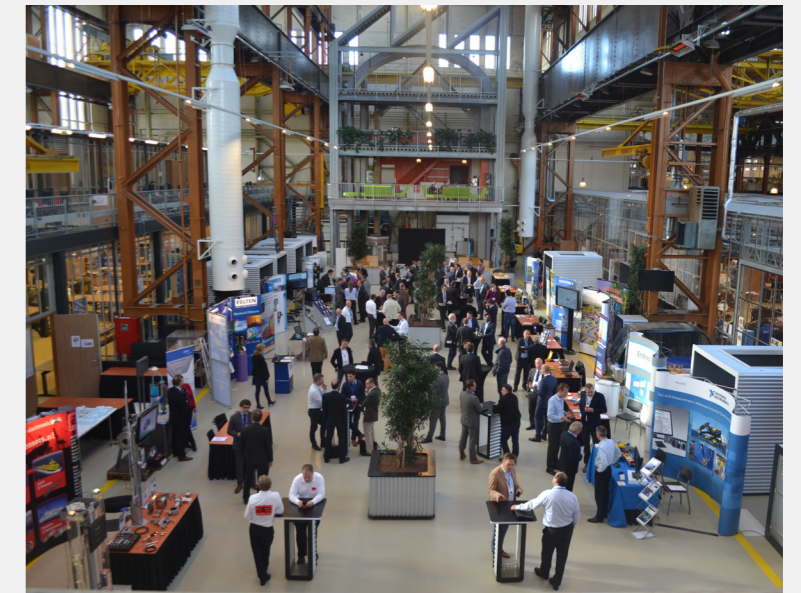

Van Gendhallen

Casus



Oostenburg

Industrieel eiland in het centrum



Oostenburg

Van Gendhallen



Erfgoed als basis voor herontwikkeling

Industriële ensemble benutten



Erfgoed als basis voor herontwikkeling

Industrie en vakmanschap

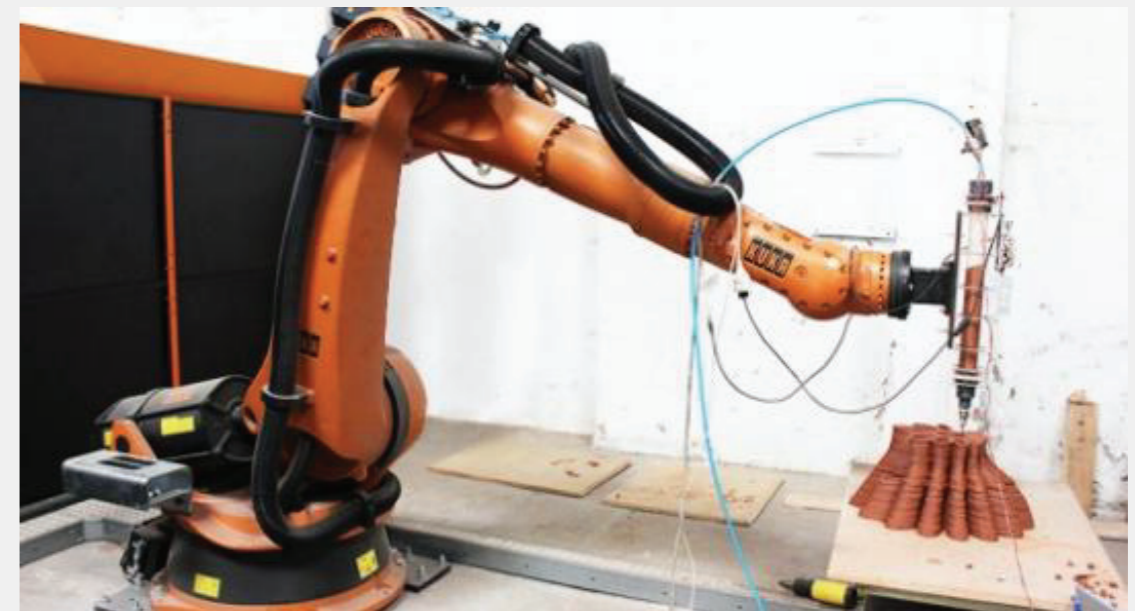
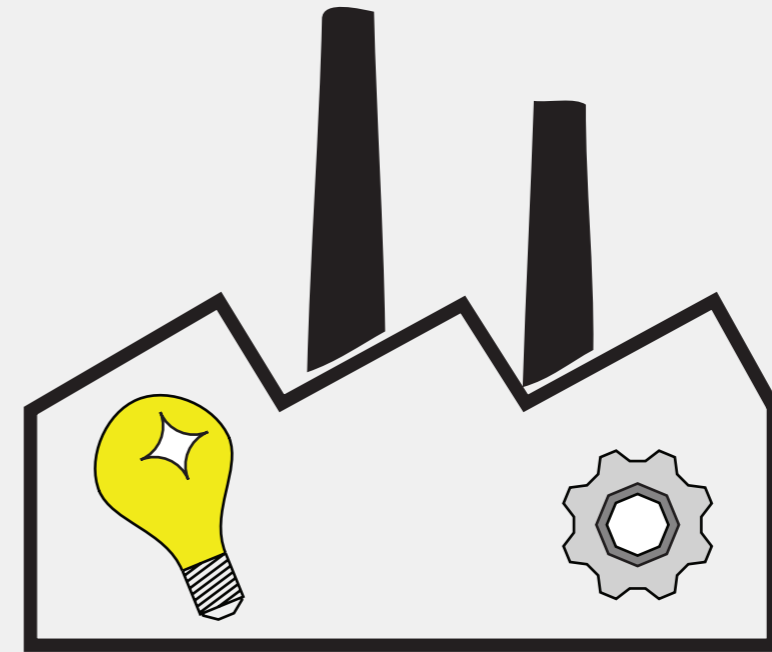

Isolatie behouden

Potentie voor uniek programma

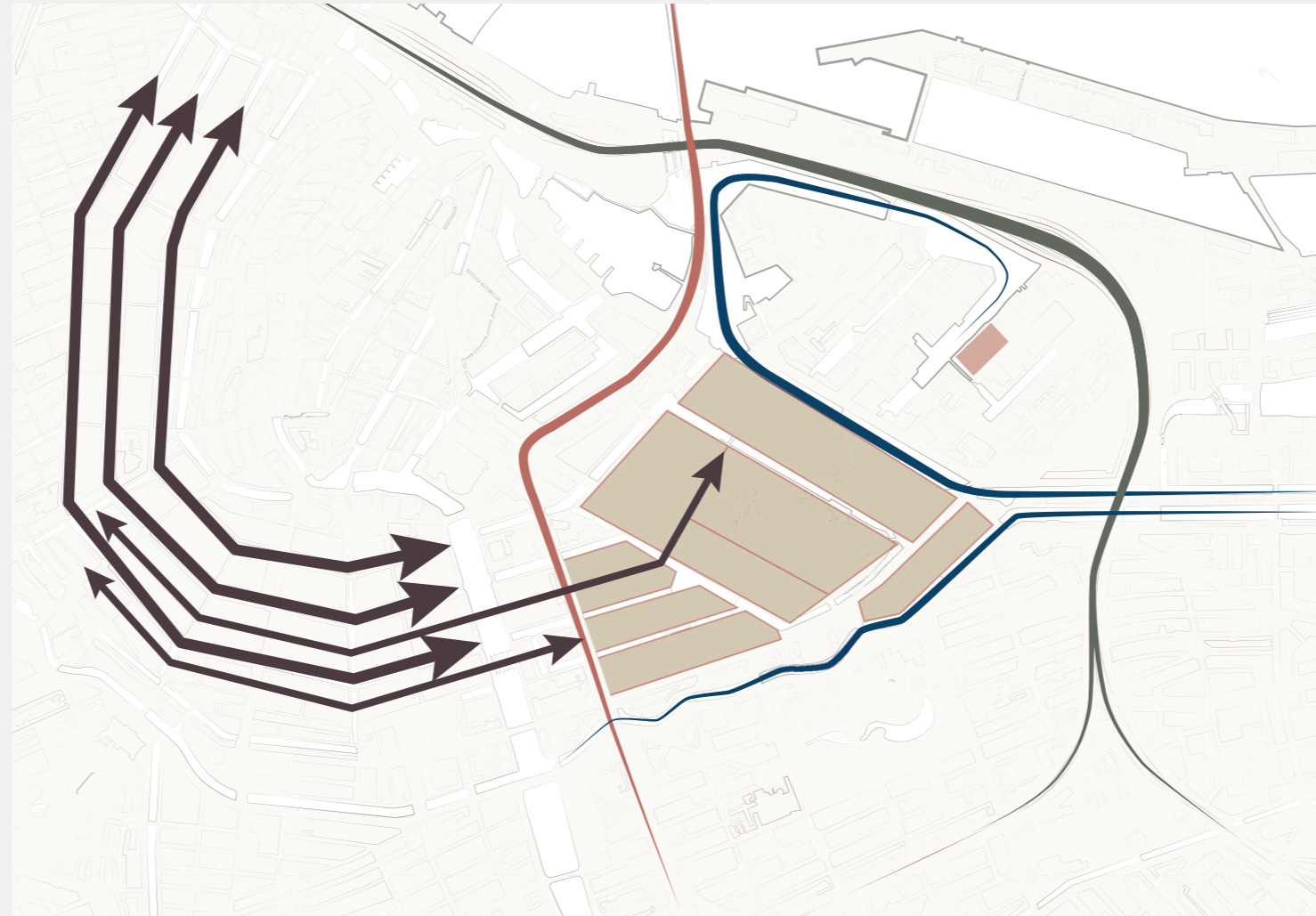

Isolated by water, infrastructure and city blocks



Eindeloos Ritme

Sterke ritmiek in Facade en constructie

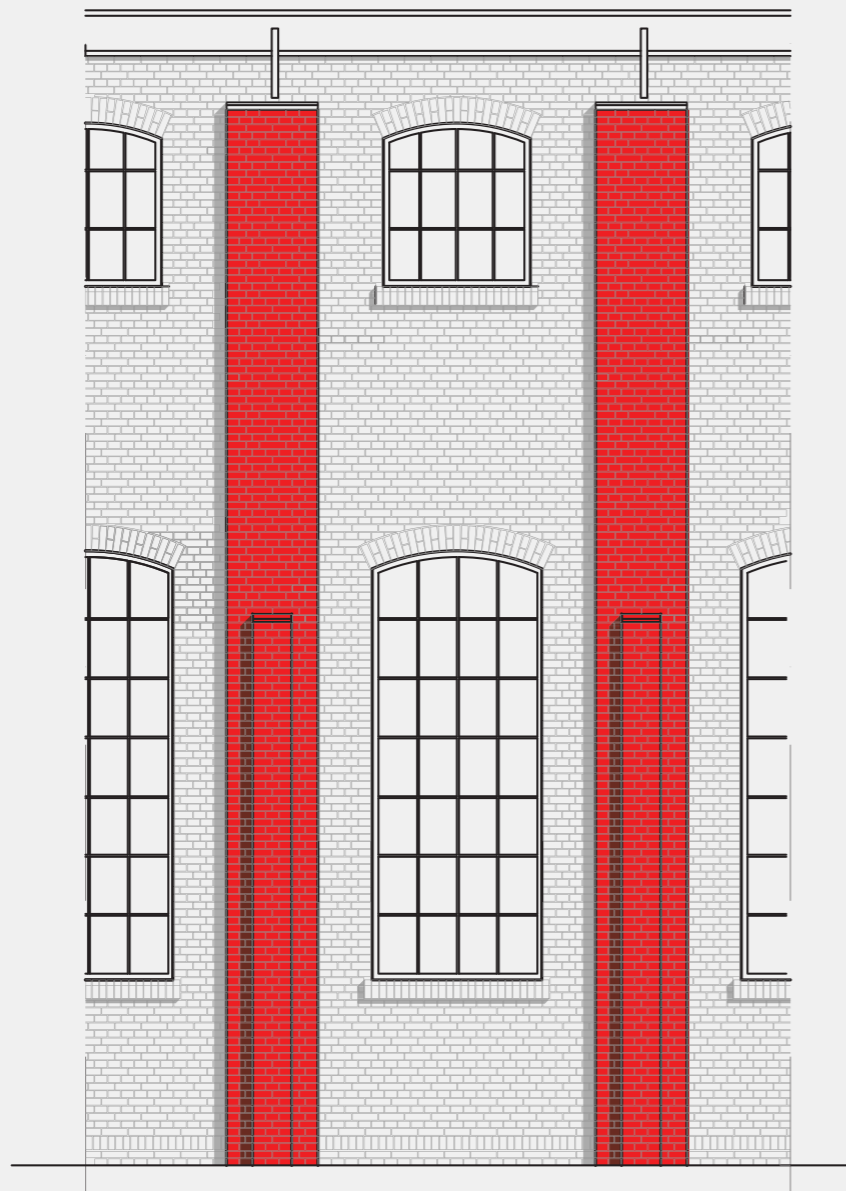

Ritme in de facade



Endless repetition



Eindeloos Ritme

Sterke ritmiek in Facade en constructie

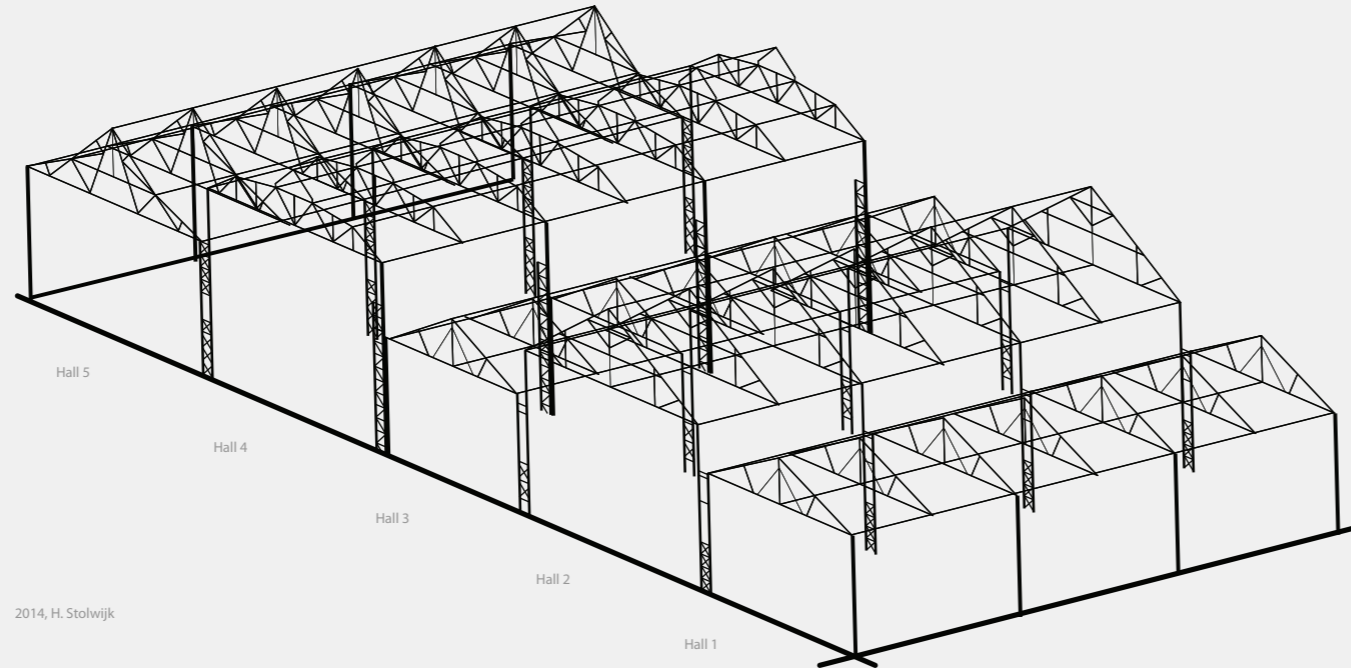

2014, H. Stolwijk

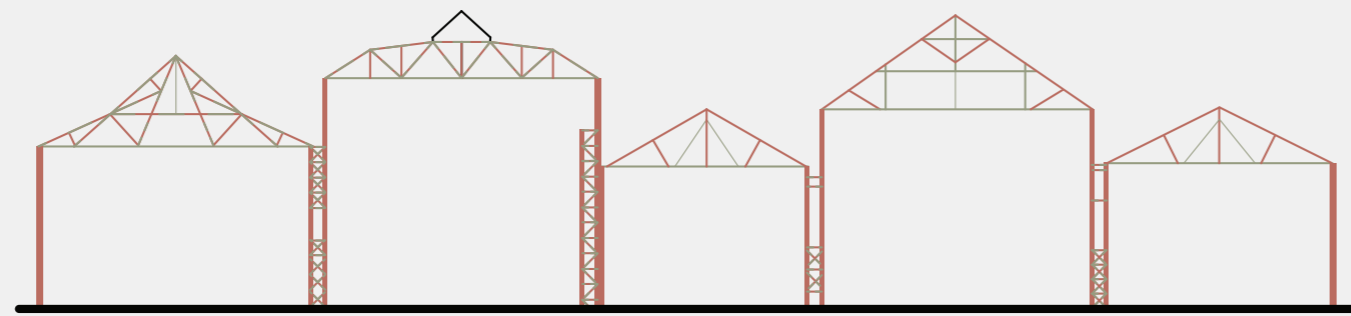

Stability construction through the halls
2014, H. Stolwijk



Bovenmenselijke schaal

Schaal & ruimtelijkheid



Industriële resten inzetten

Voor behoud van immaterieele waarden

Atmosfeer, karakter en identiteit

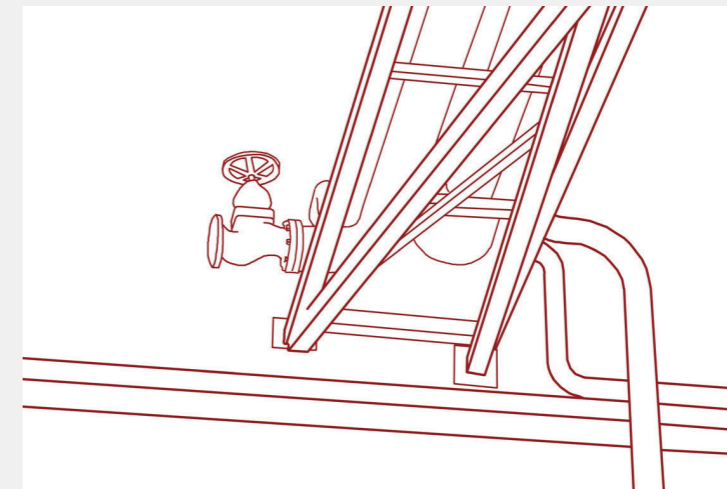
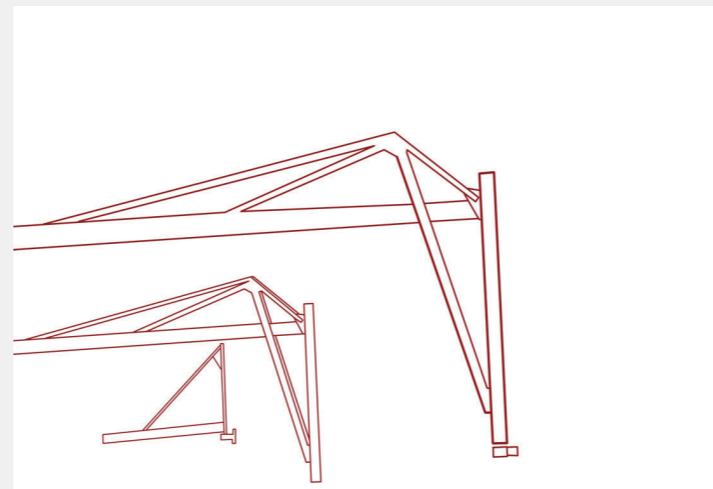
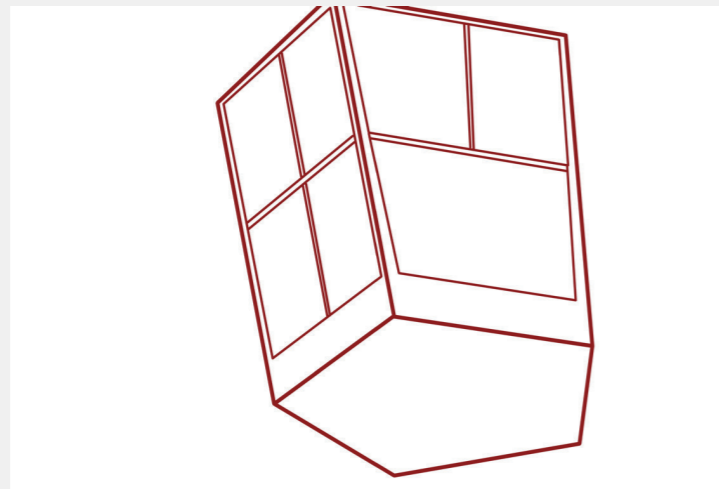

“Built heritage and sites in which we invest so much effort to preserve are after all, the vessels for cultural values, an intangible heritage.” *(Bumbaru, 2000)*



Reflectie P2

Urban Design

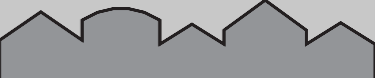
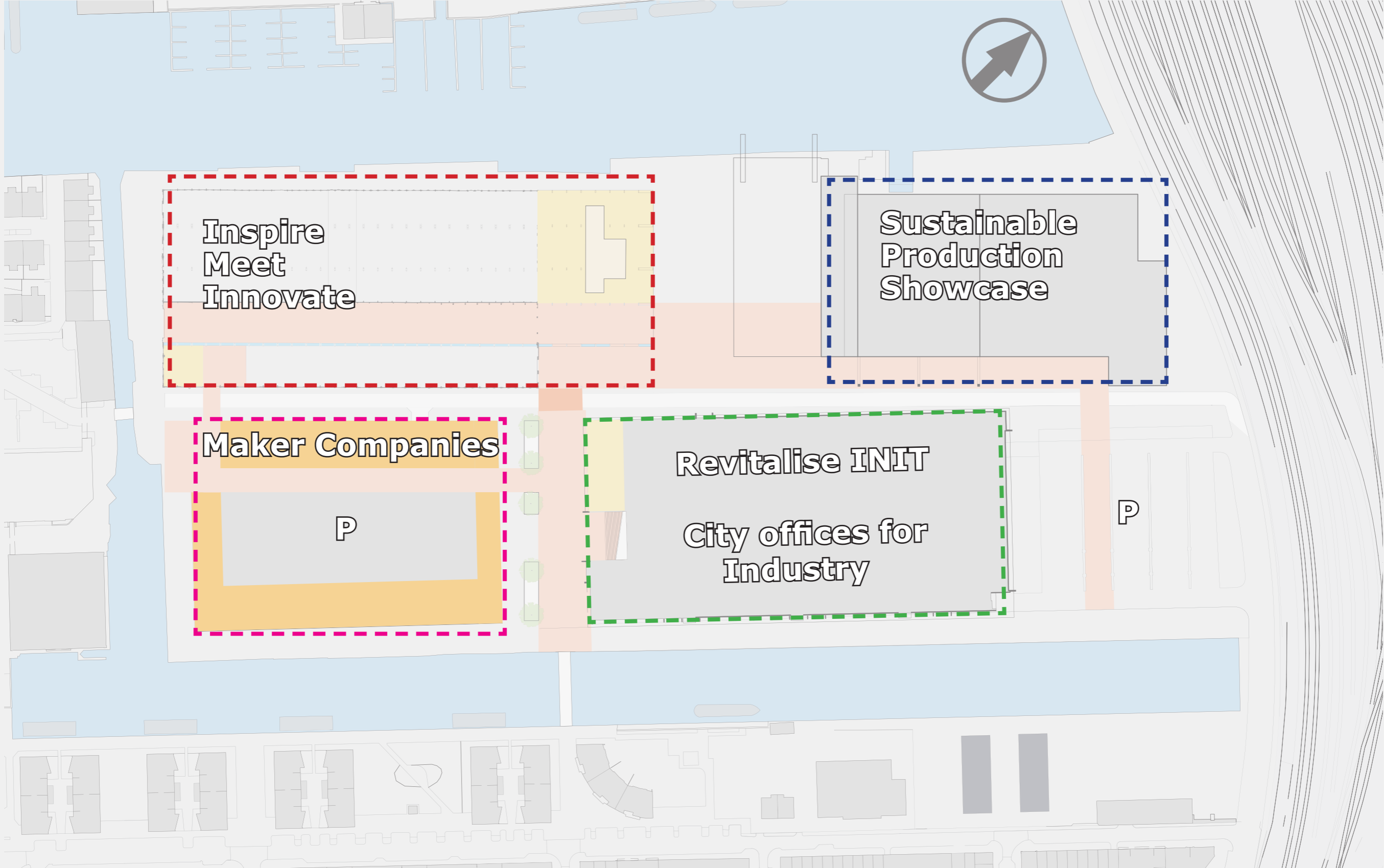

Reflectie P2

Uitdagingen

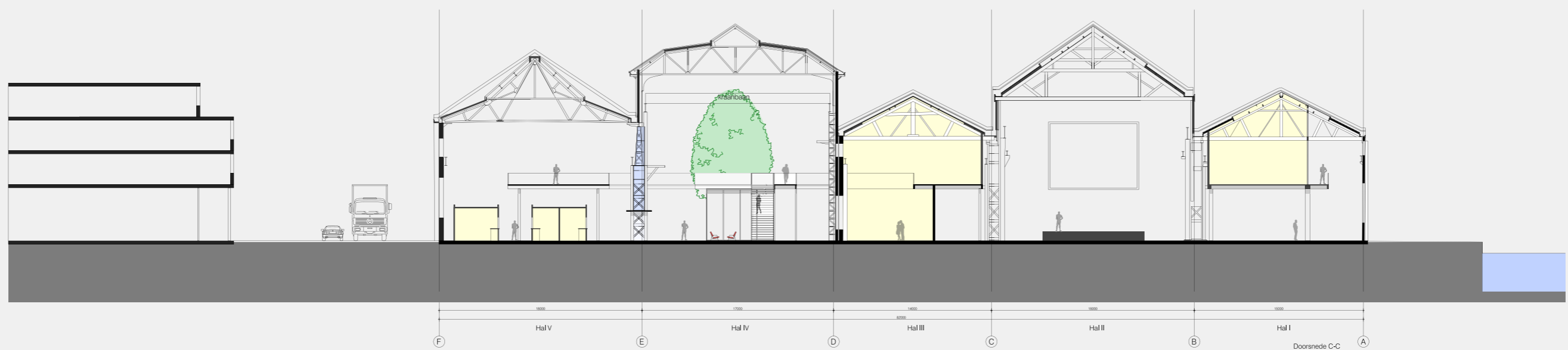
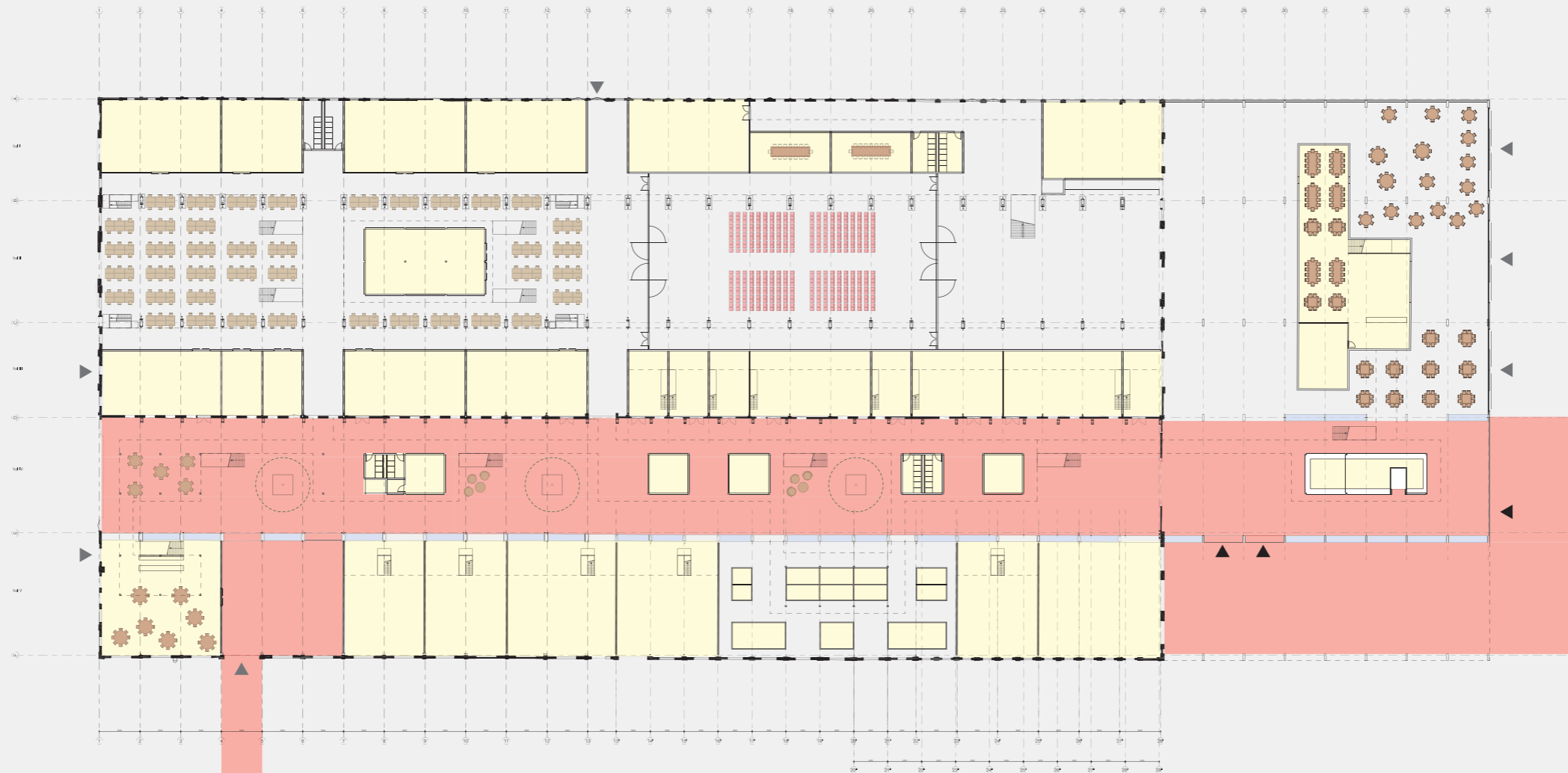

Ruimtelijkheid en verdichting



Reflectie P2

Facades

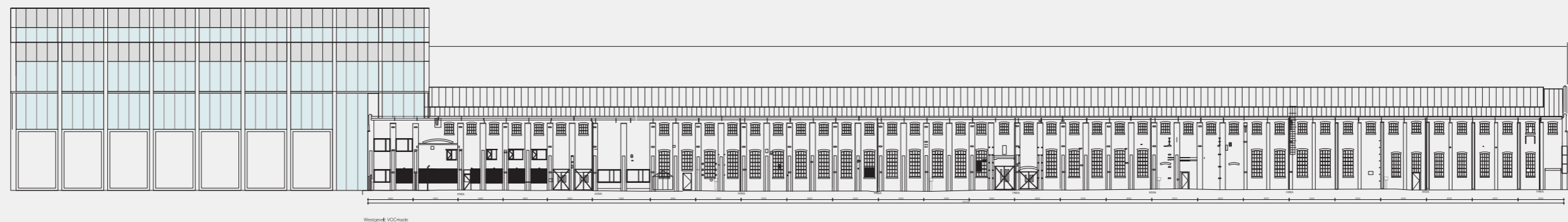
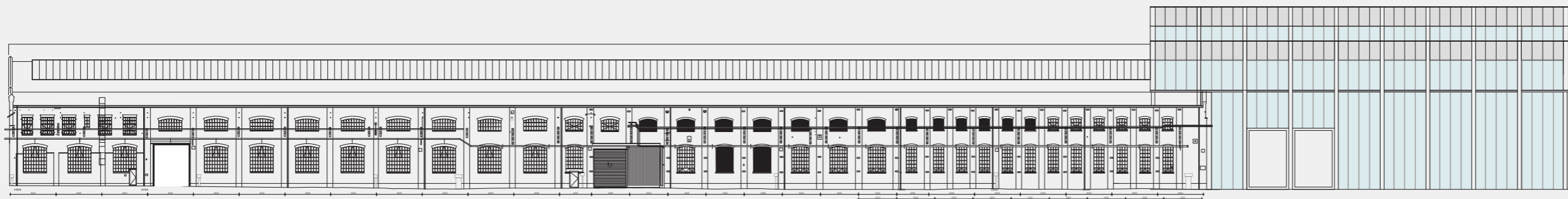

Reflectie P2

Gevel en klimaat



Reflectie P2

Focus

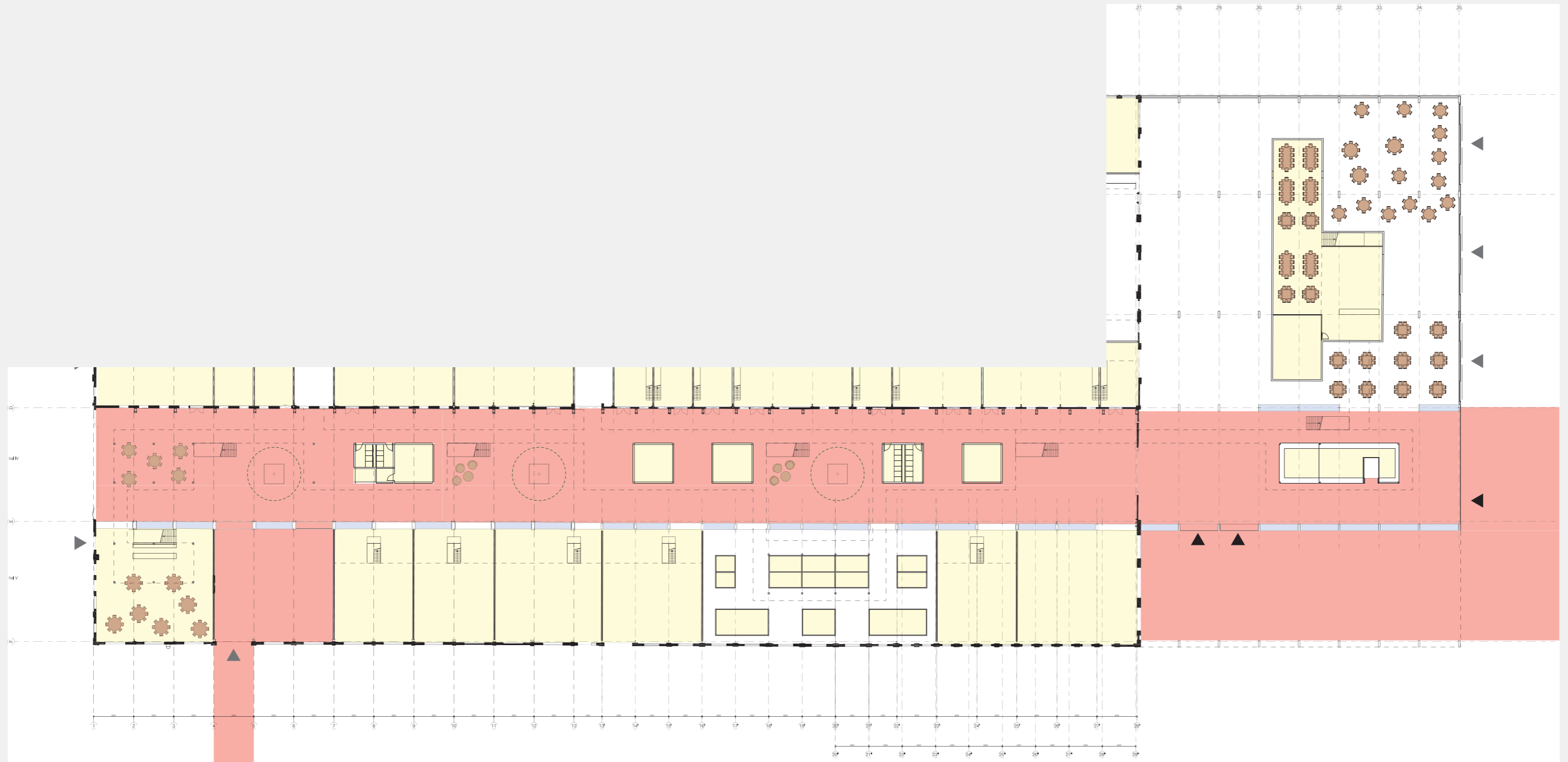

Reflectie P2

Focus



Van Gendt redeveloping Industry

Platform voor de Maakindustrie

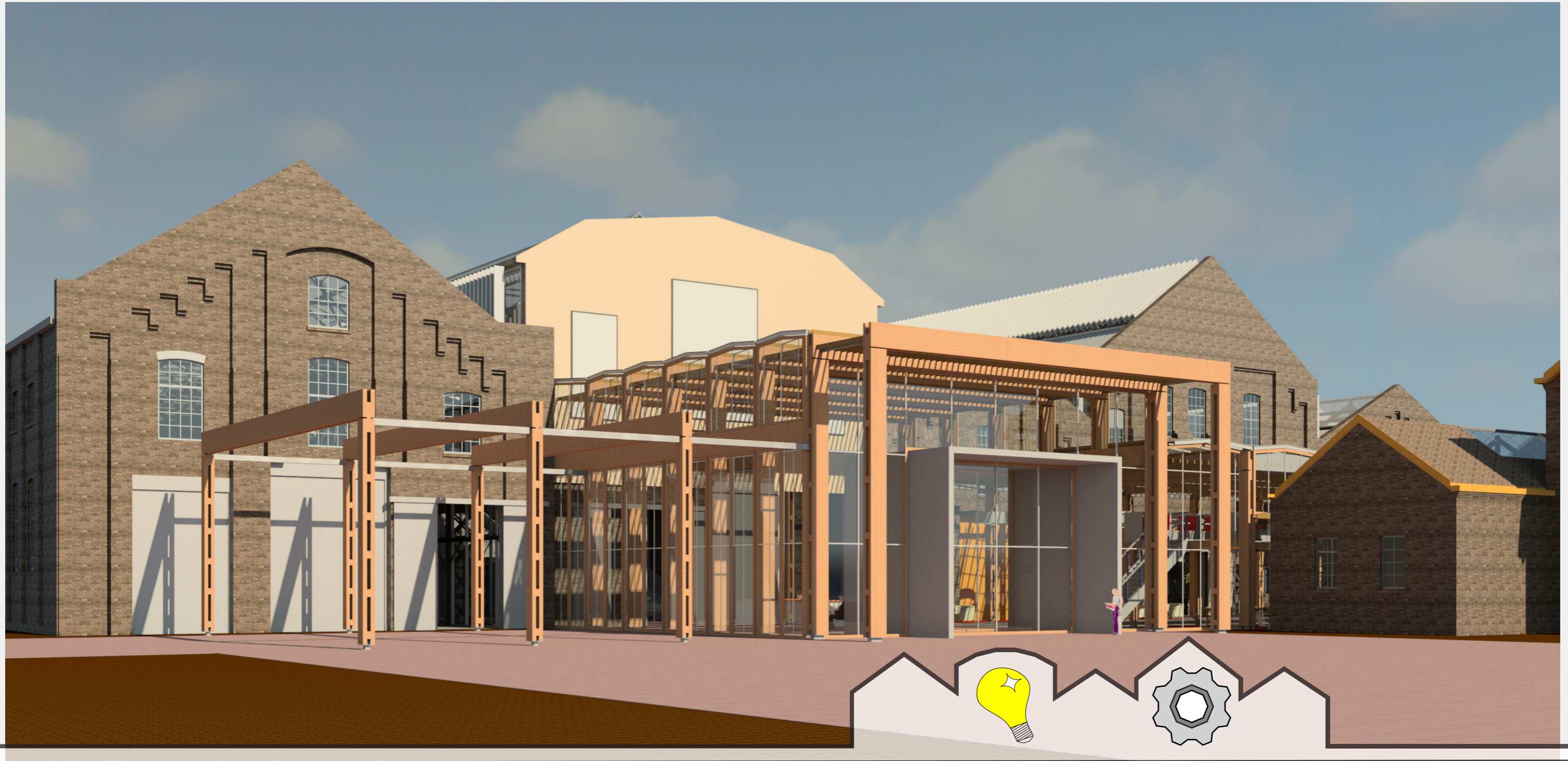

Bestaande situatie

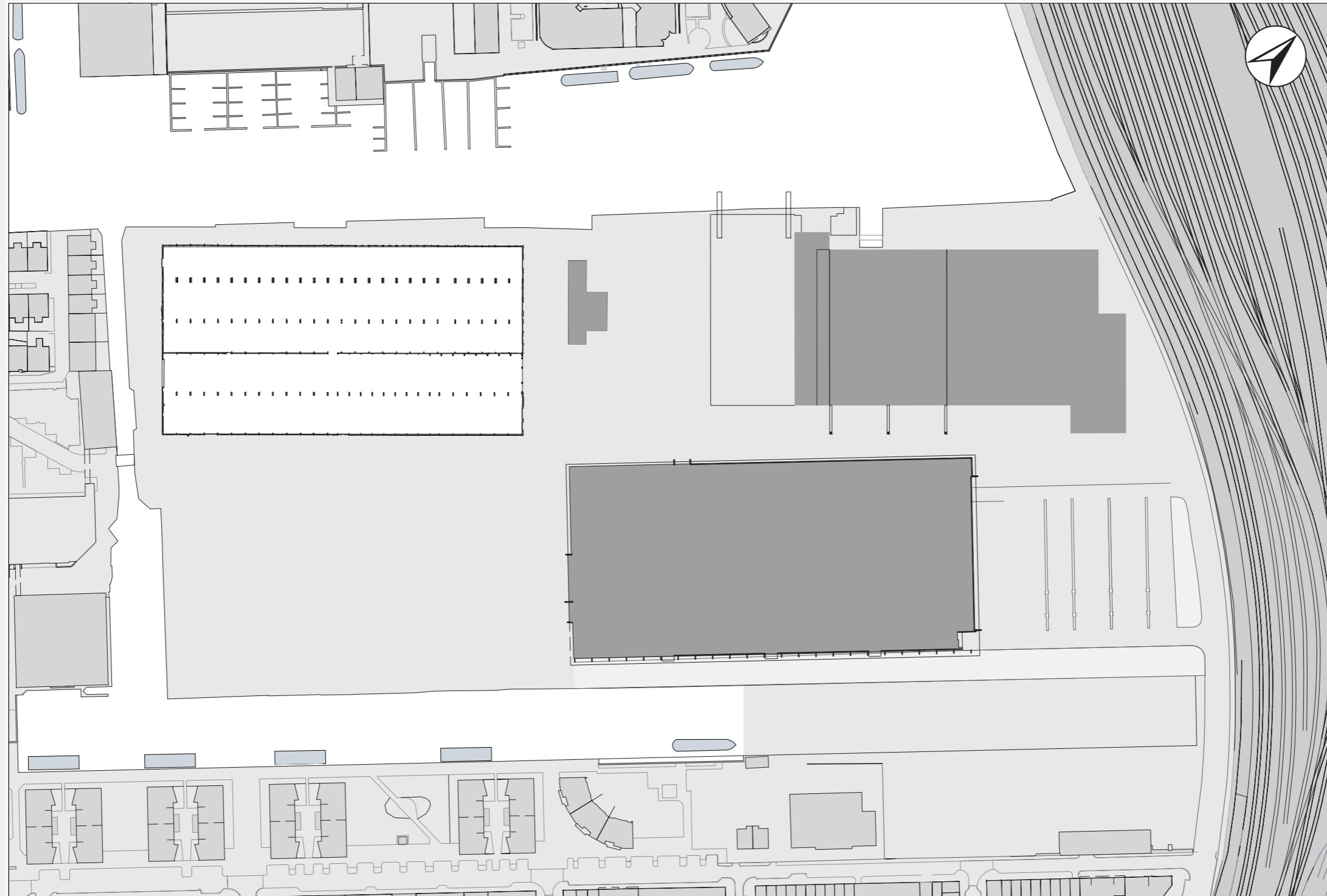

Isolatie

Potentie voor unieke functie

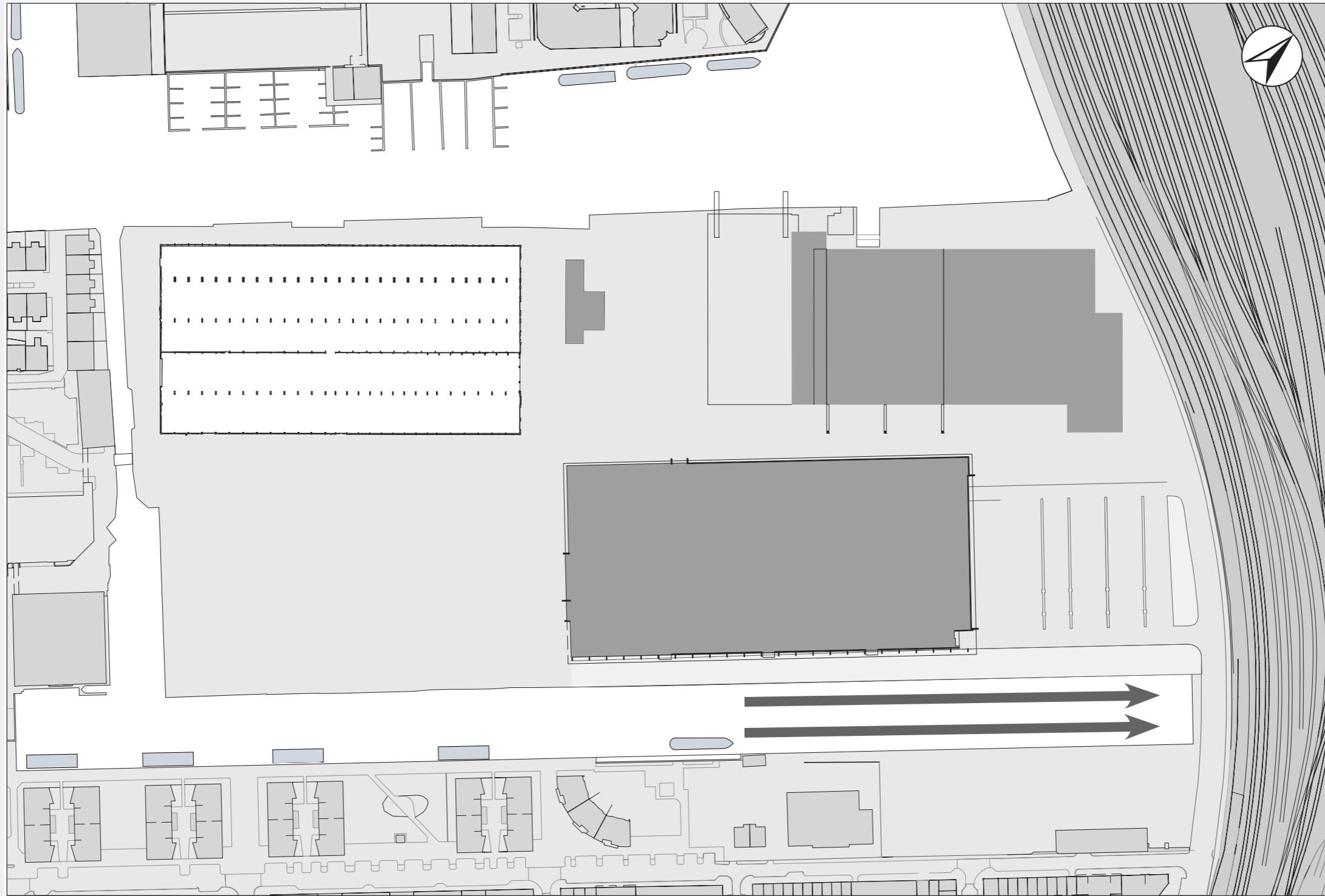

Verbinding

Centrale as verbind Industrieel Ergoed

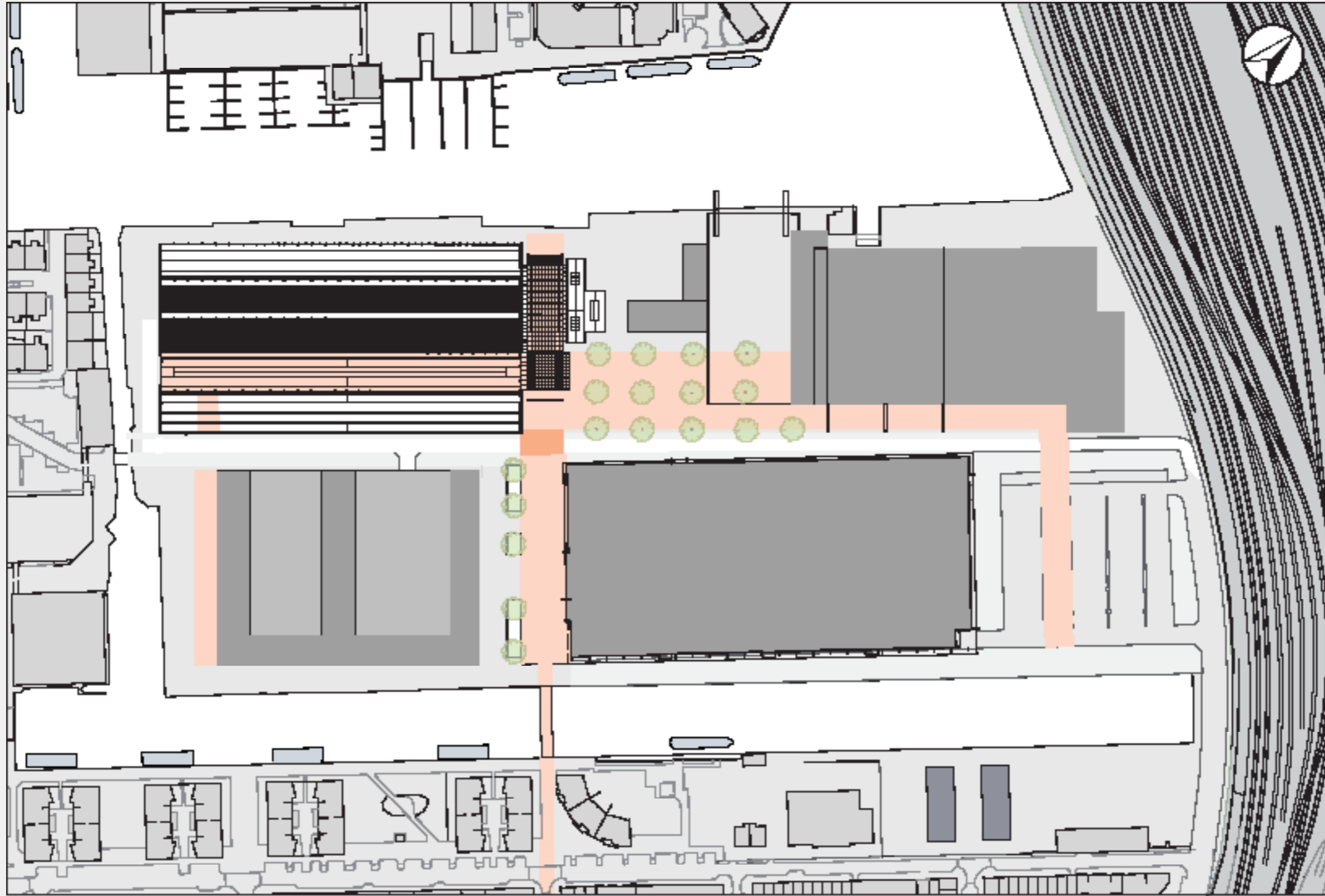

Platform voor de Maakindustrie

Conferentie centrum & Incubator nmet industrieel karakter

Ontmoeten

Inspireren

Werken

Creëren

Delen

Innoveren



Platform voor de Maakindustrie

Verbindende as

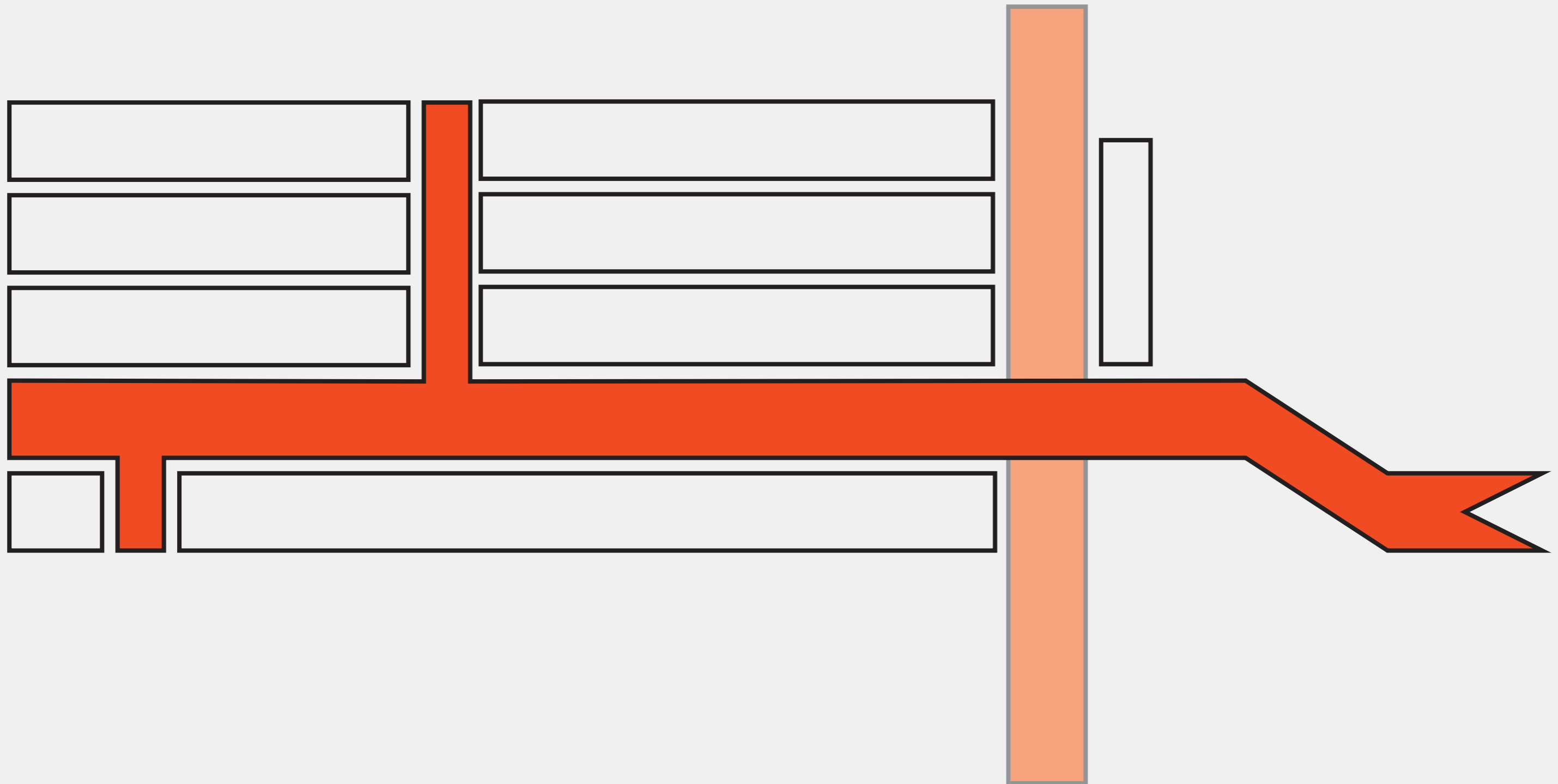

Platform voor de Maakindustrie

Conferentie Centrum: Ontmoeten & Inspireren

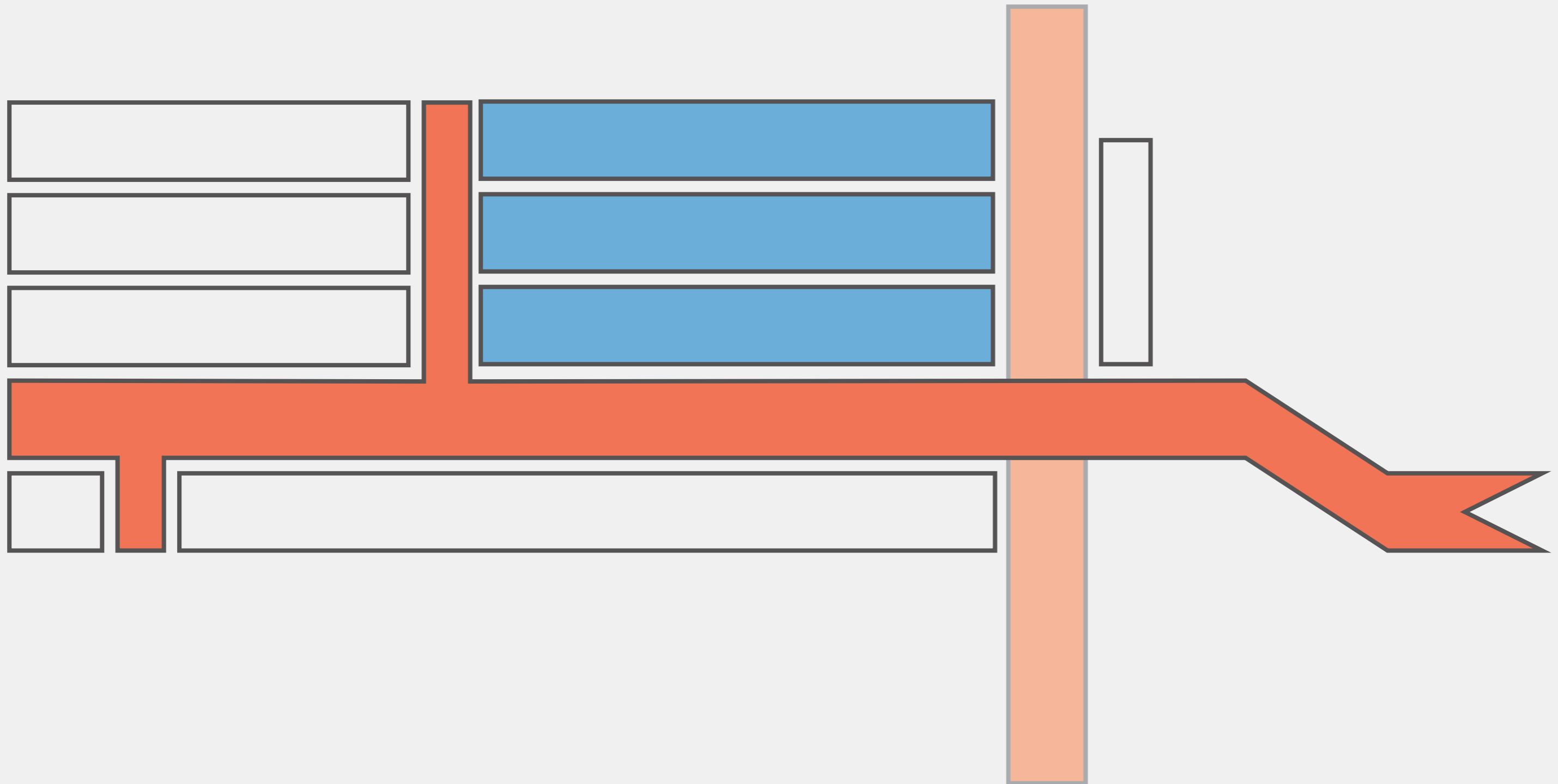

Platform voor de Maakindustrie

Incubator: Werken en Creëren

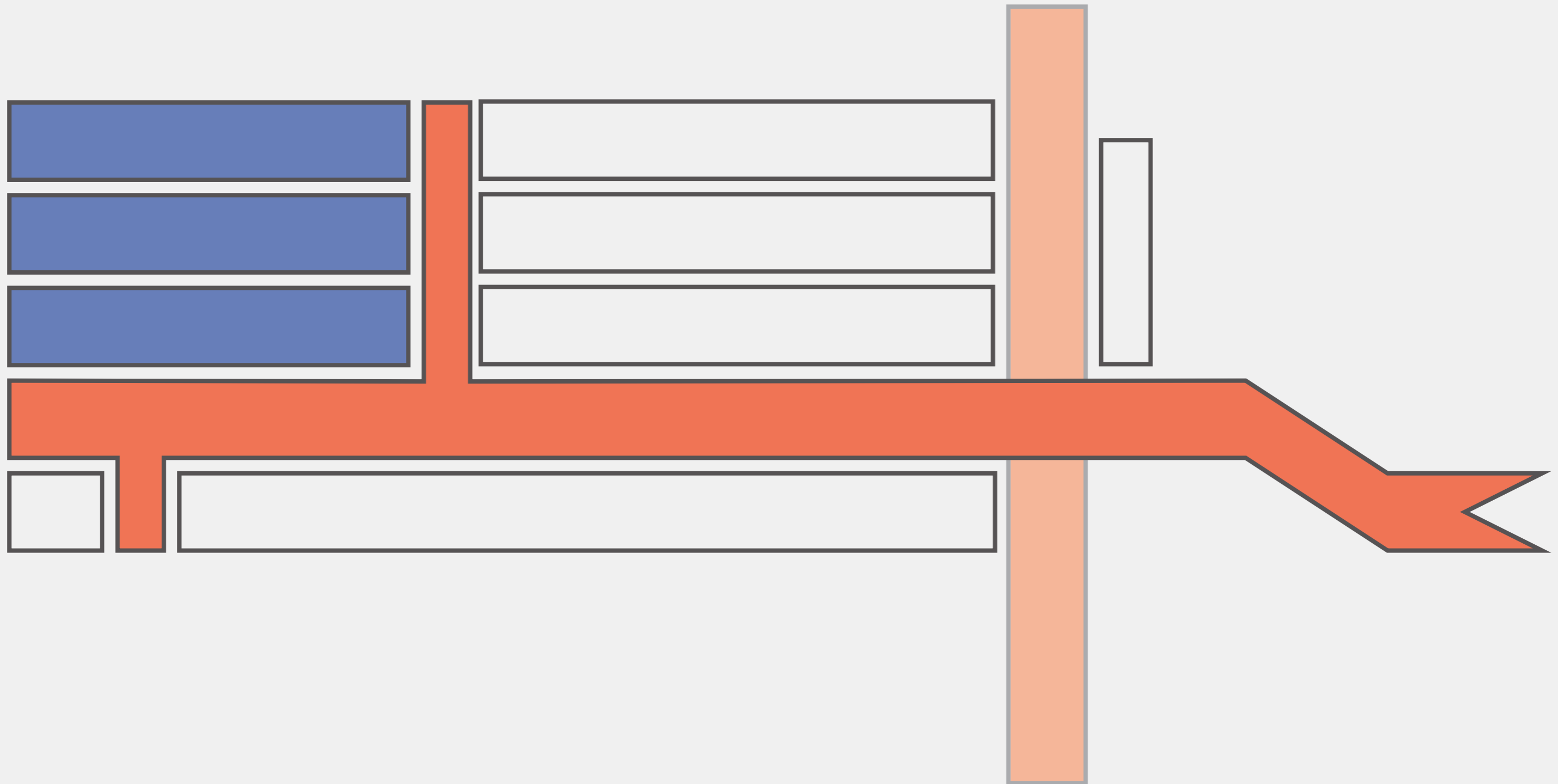

Platform voor de Maakindustrie

Delen en Innoveren

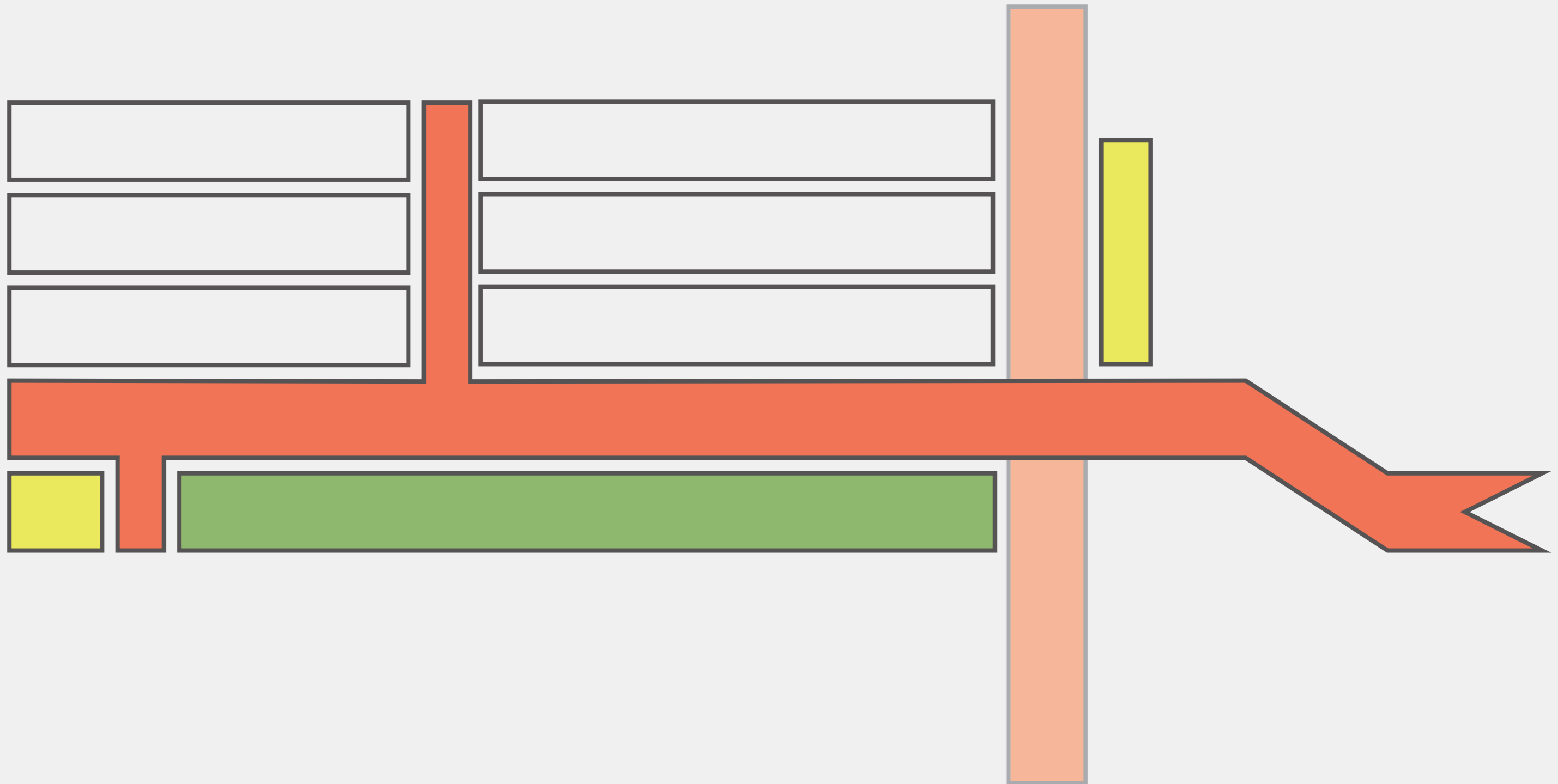

Platform voor de Maakindustrie

Besloten Karakter & openbaar Programma

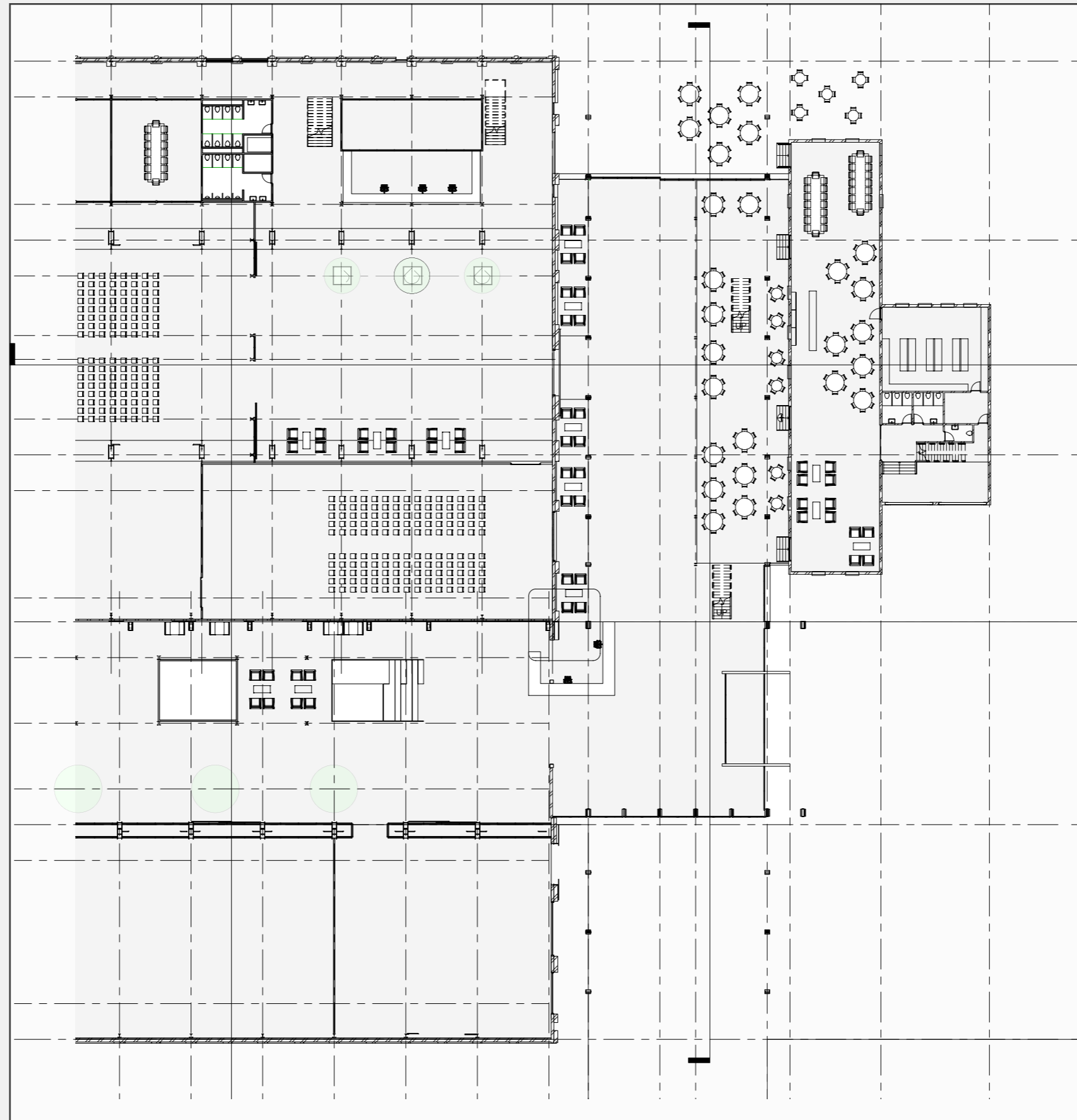

Overgang

Nieuwe entree met open karakter



Connectie

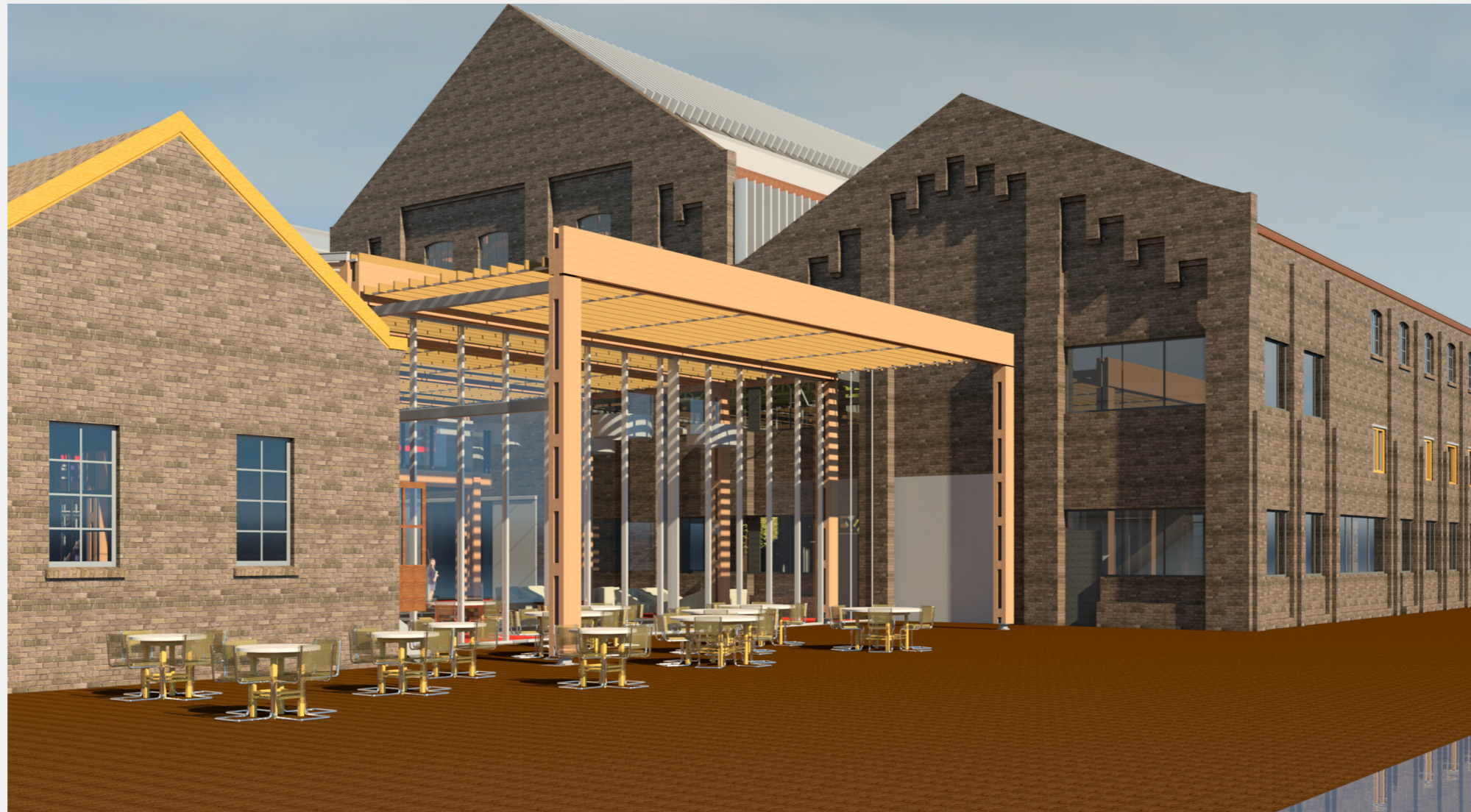

Nieuwe Hal

Vrijstaande dwarshal

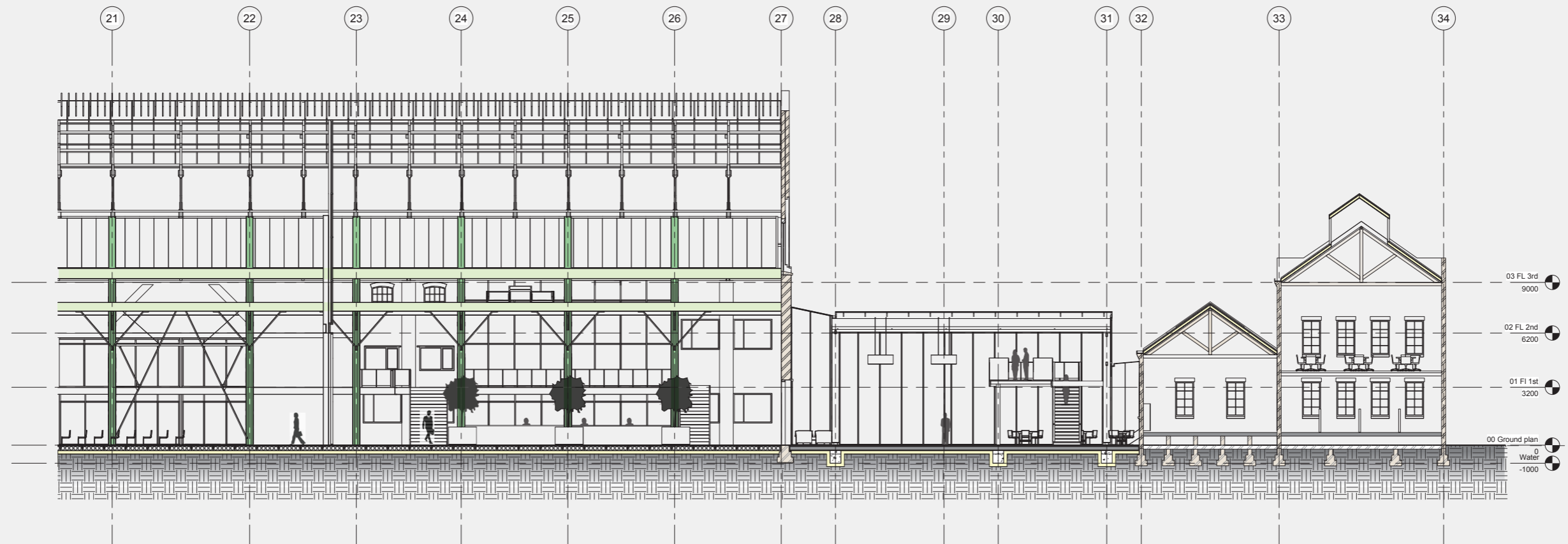

Eigen ritme en Karakter

Visueel vrij staand

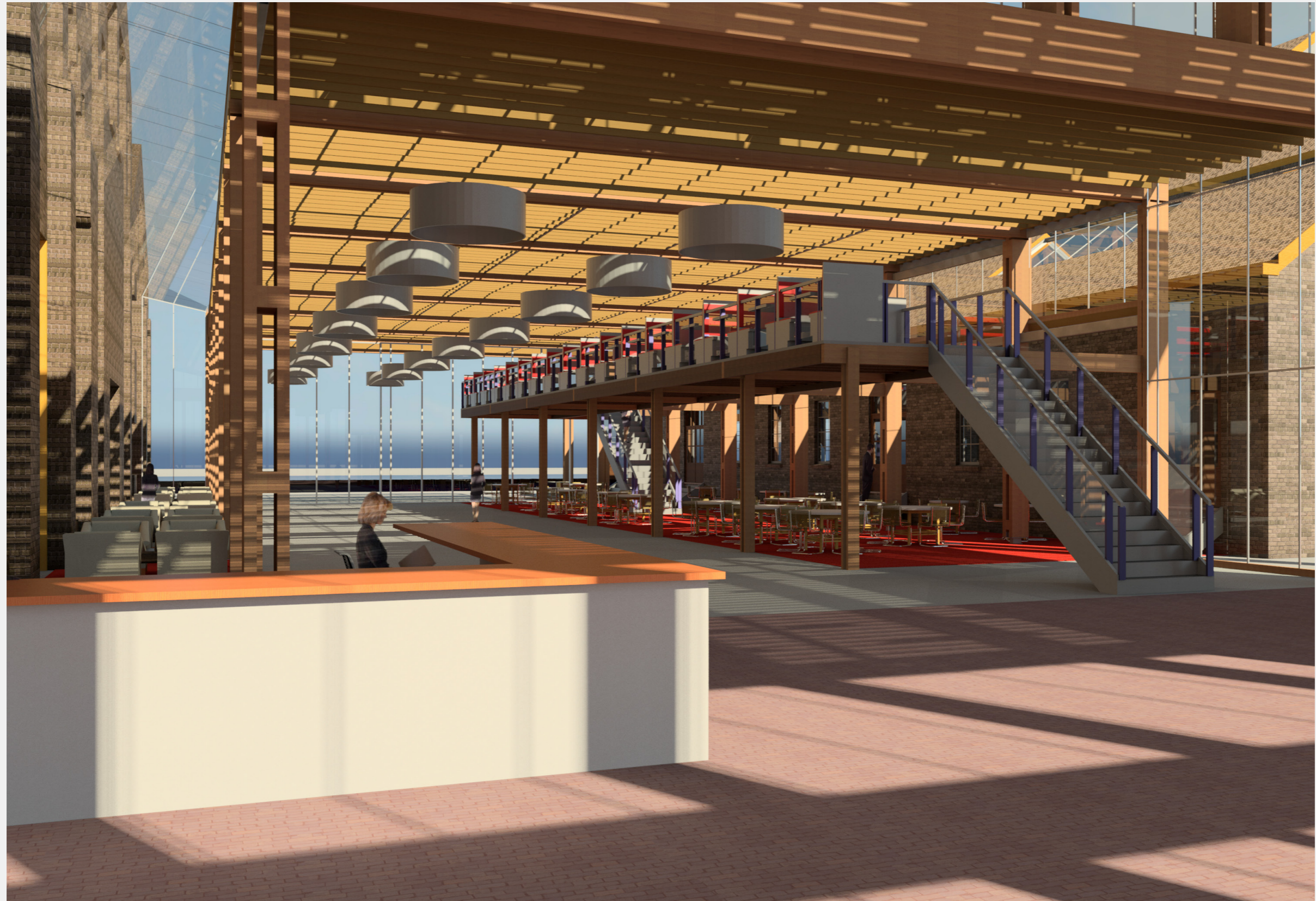

Transparante verbinding

Aansluiting gevel

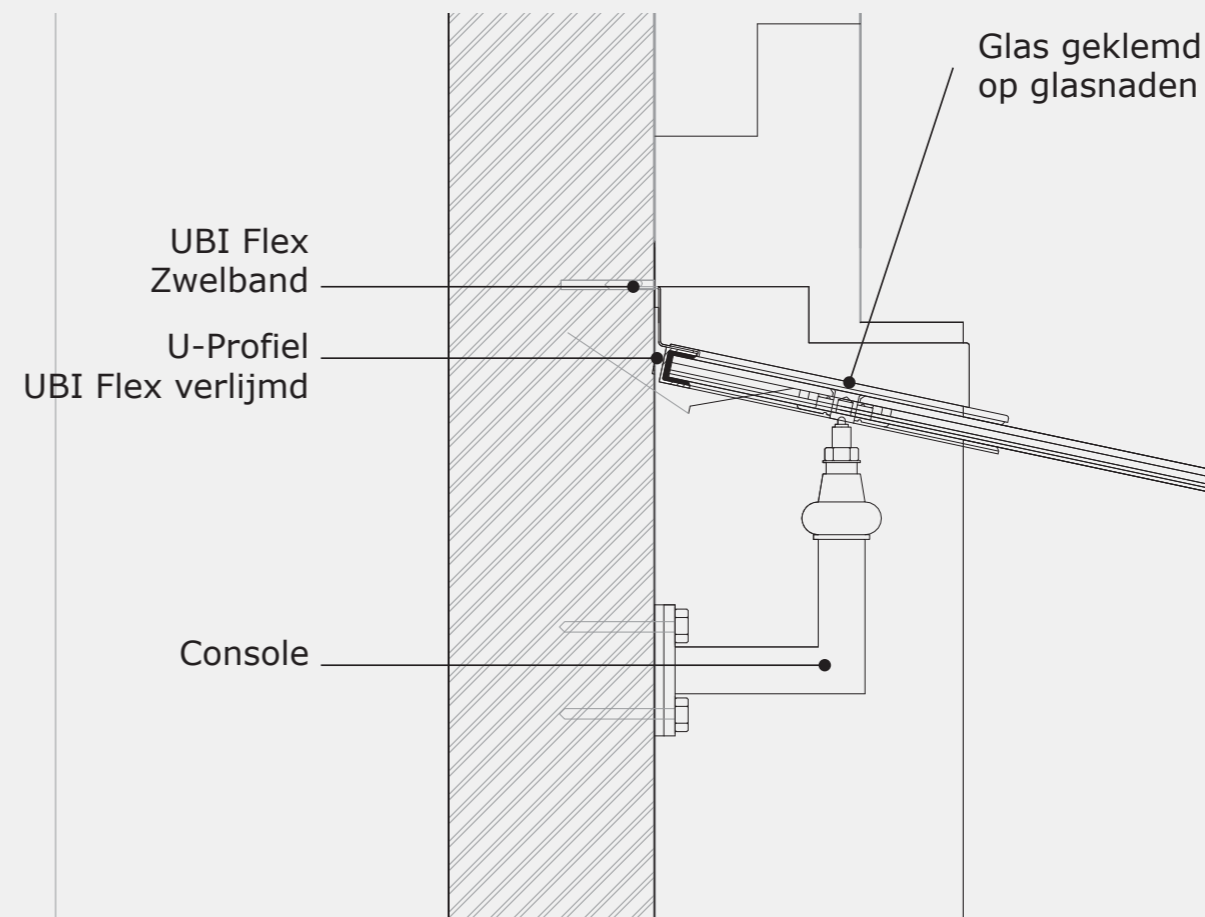
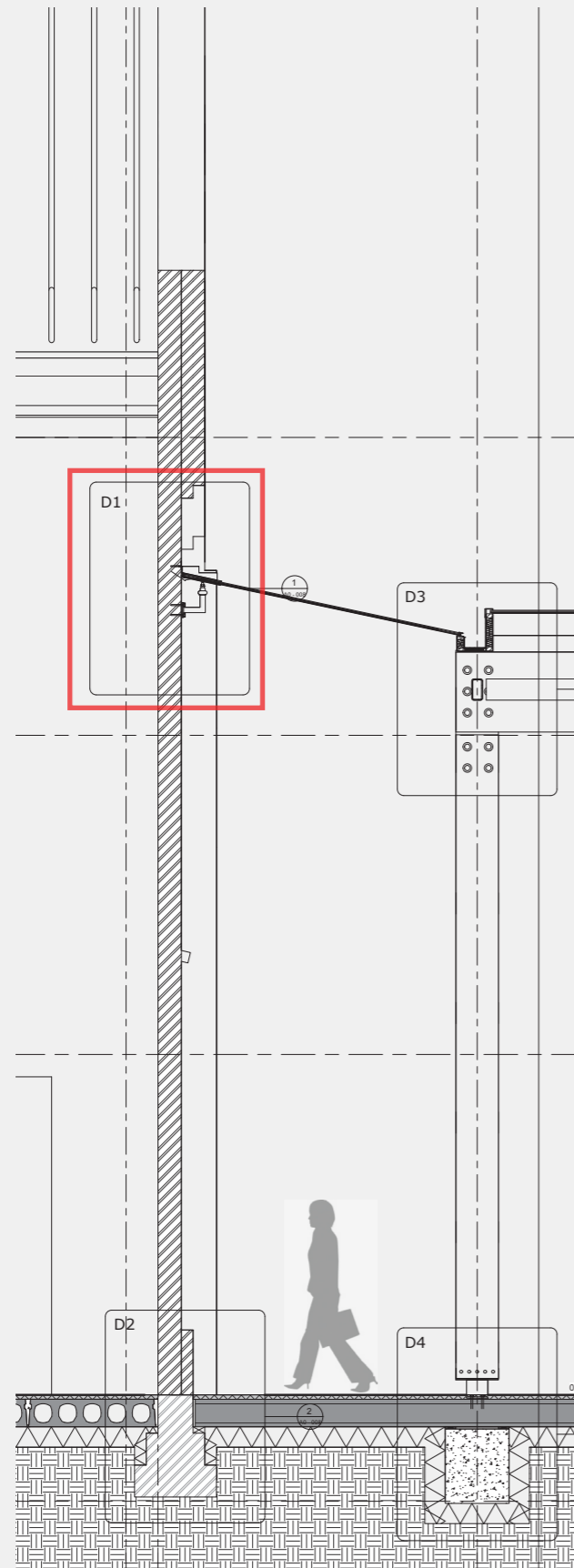

Transparante verbinding

Aansluiting goot

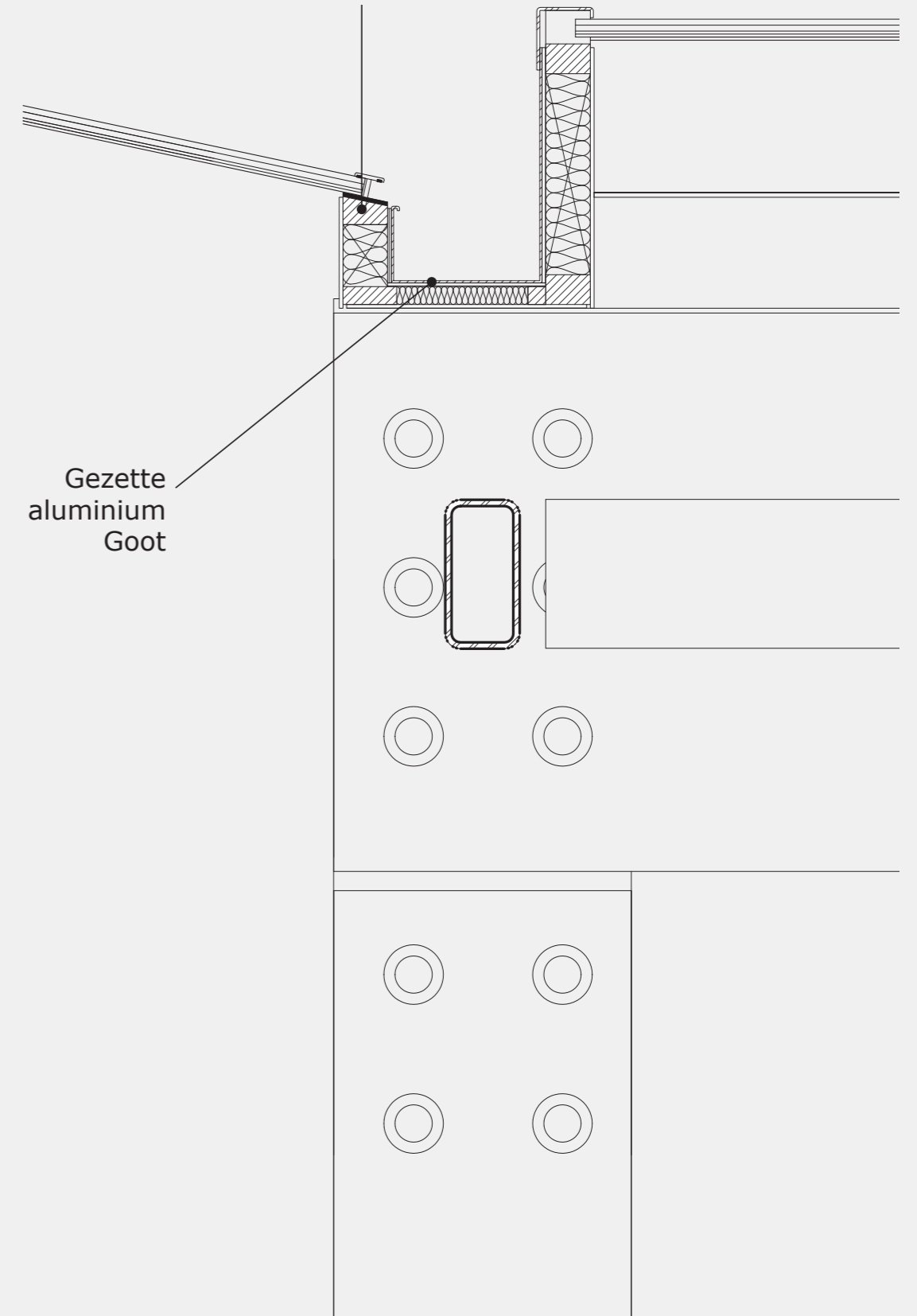
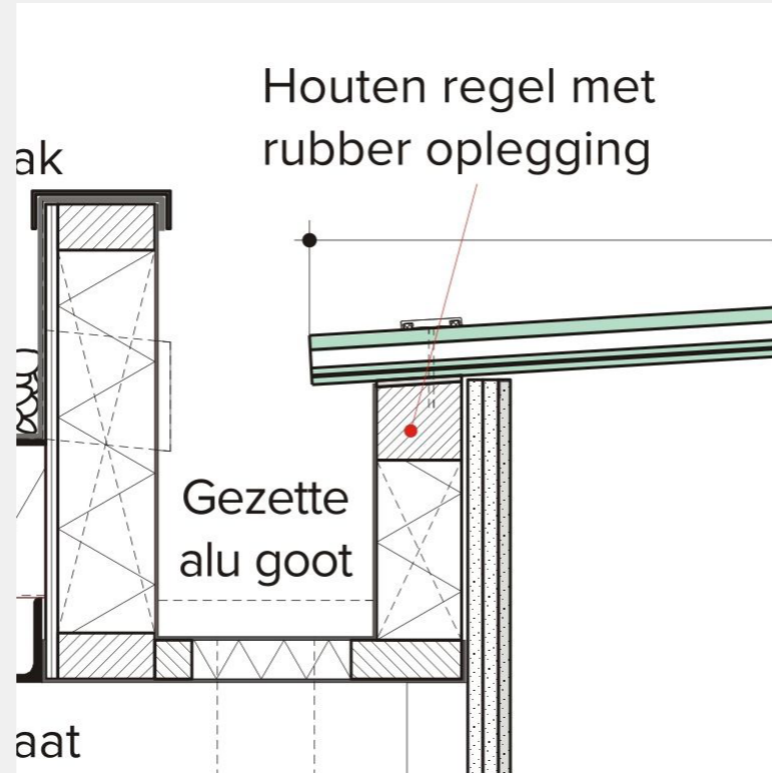
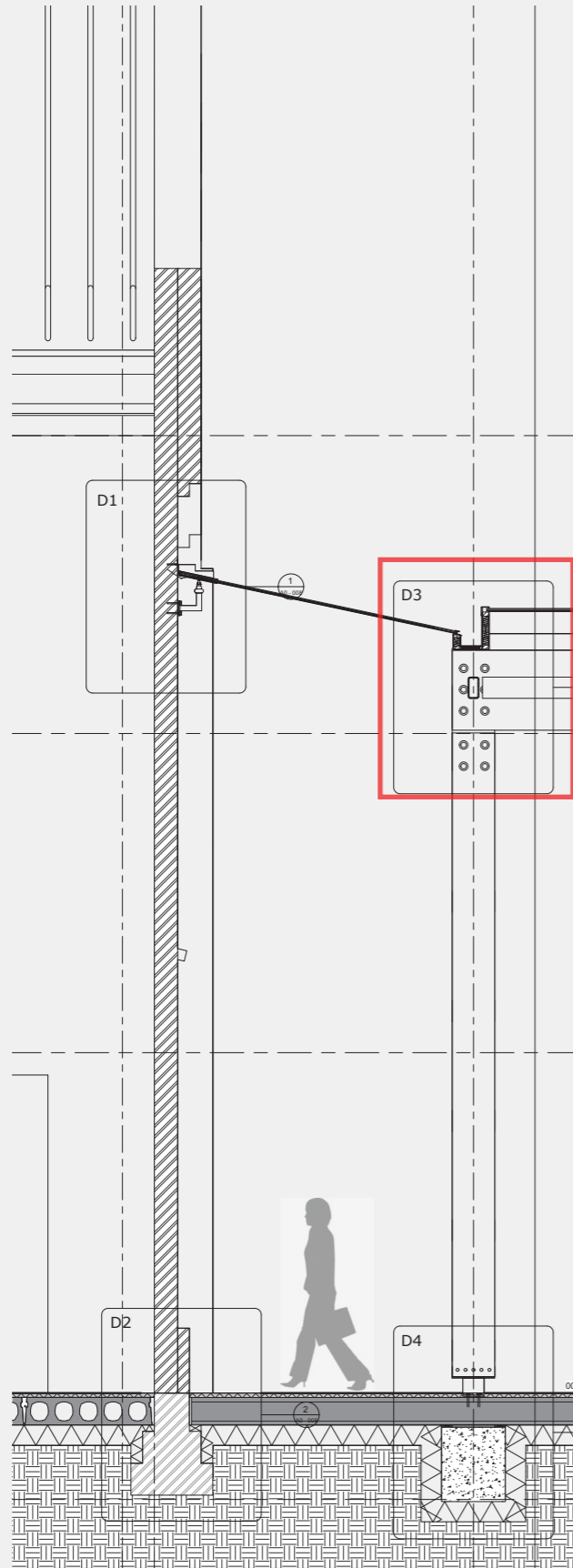

Detail 3 1:5

Verdichting & Ruimtelijkheid

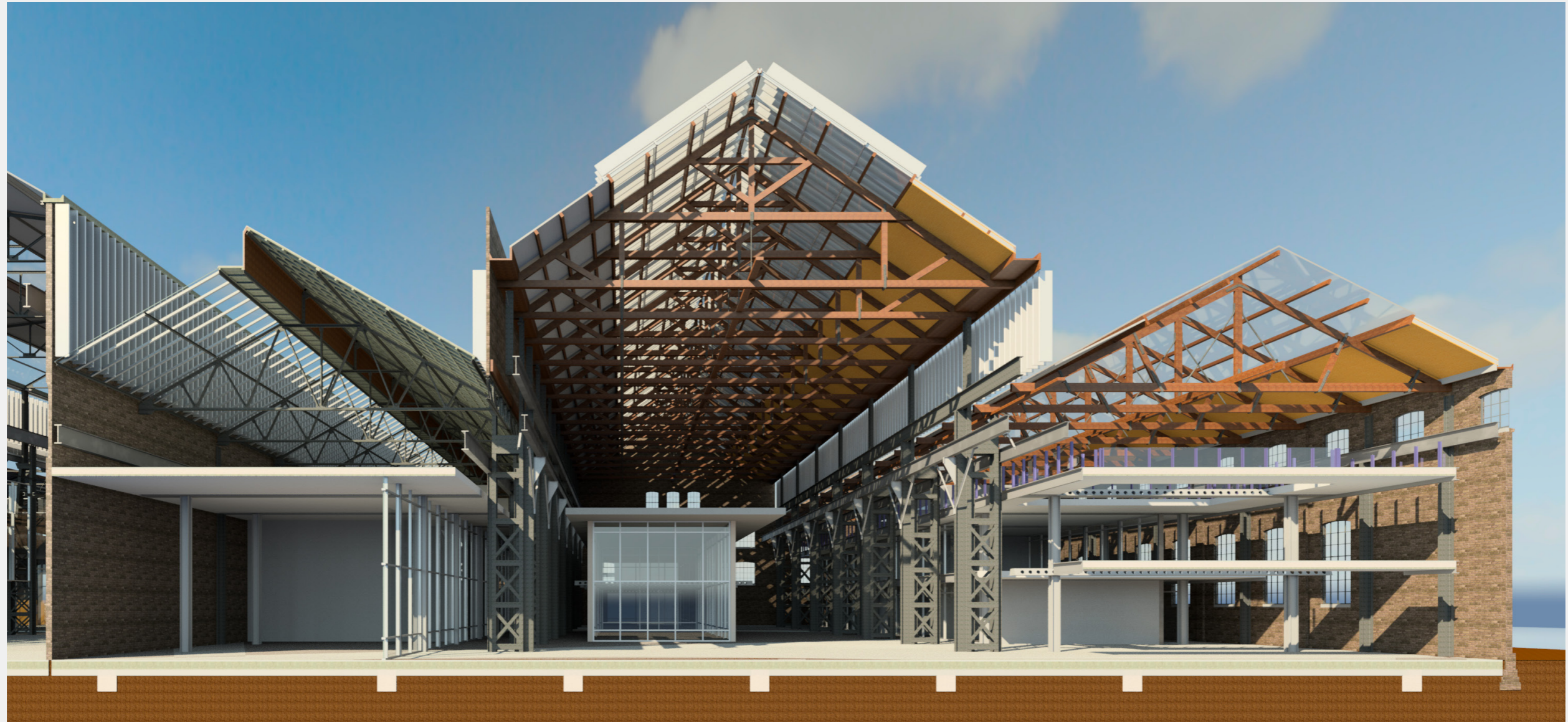

Verdichting & Ruimtelijkheid

Industrieële Constructie

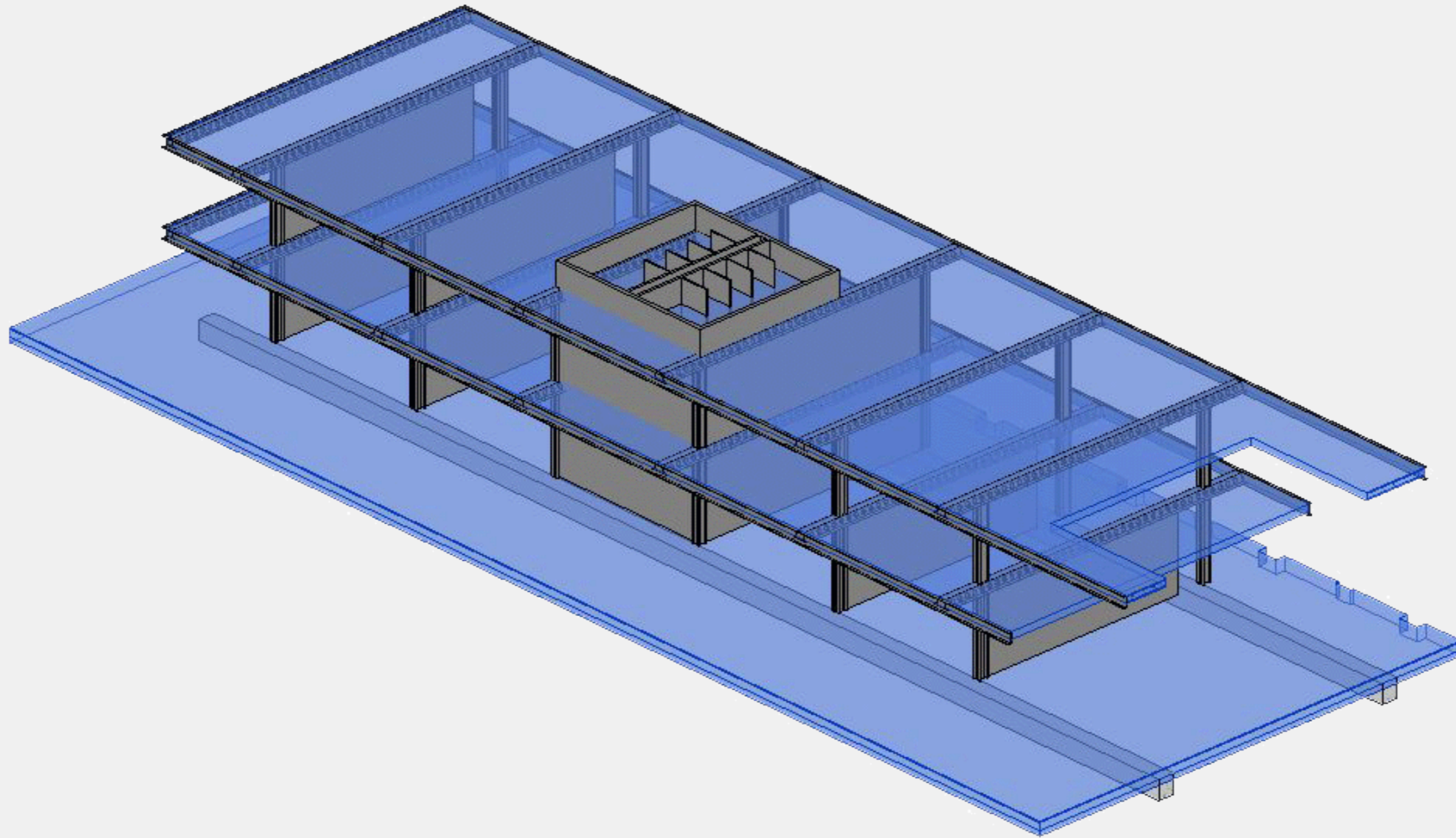

Verdichting & Ruimtelijkheid



Entree van Gendthallen

Routing van buiten naar binnen



Entree van Gendthallen

Frontdesk



Entree van Gendthallen

Tussenstop

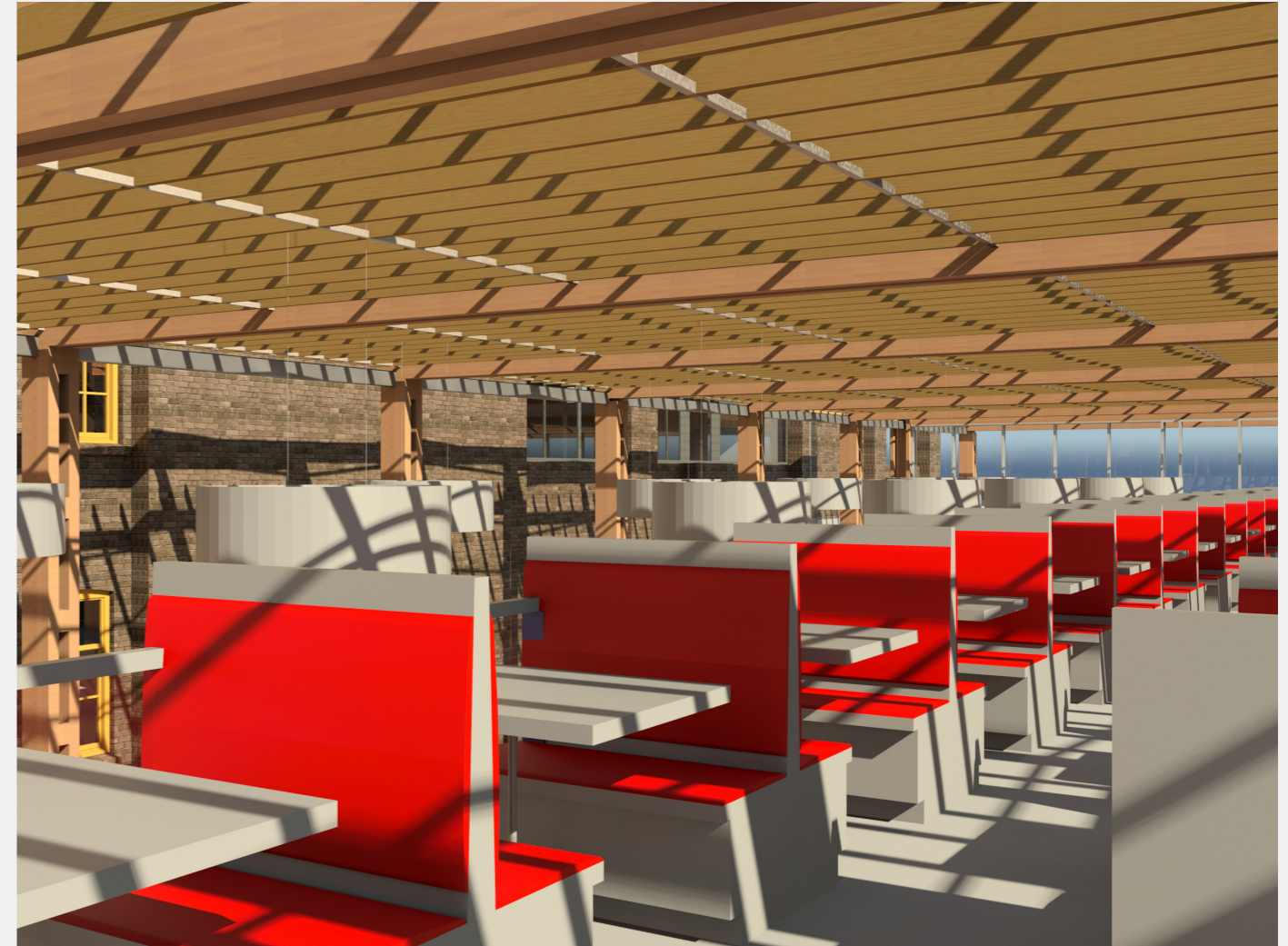
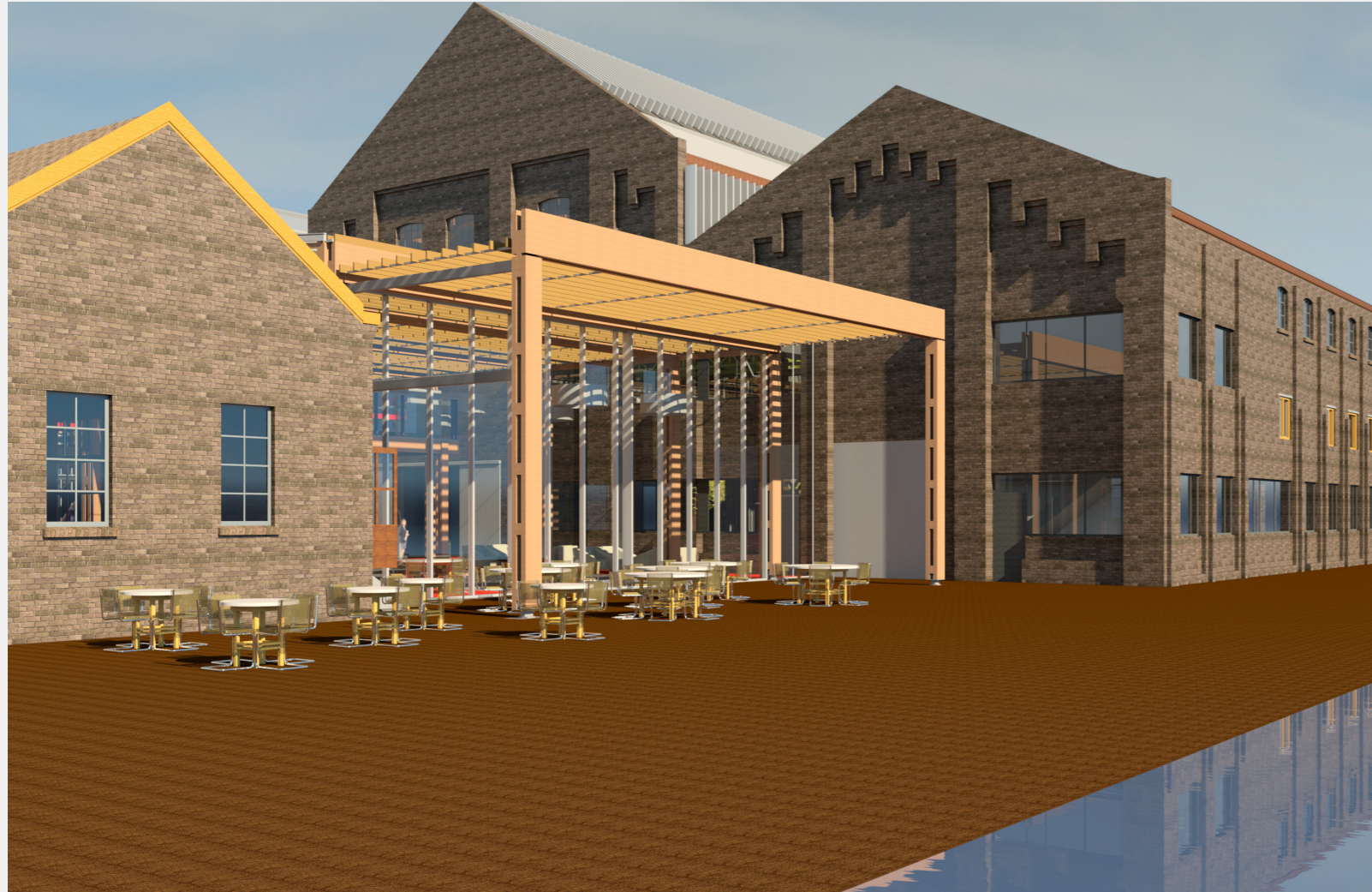

Entree van Gendthallen

toegang conferentie centrum

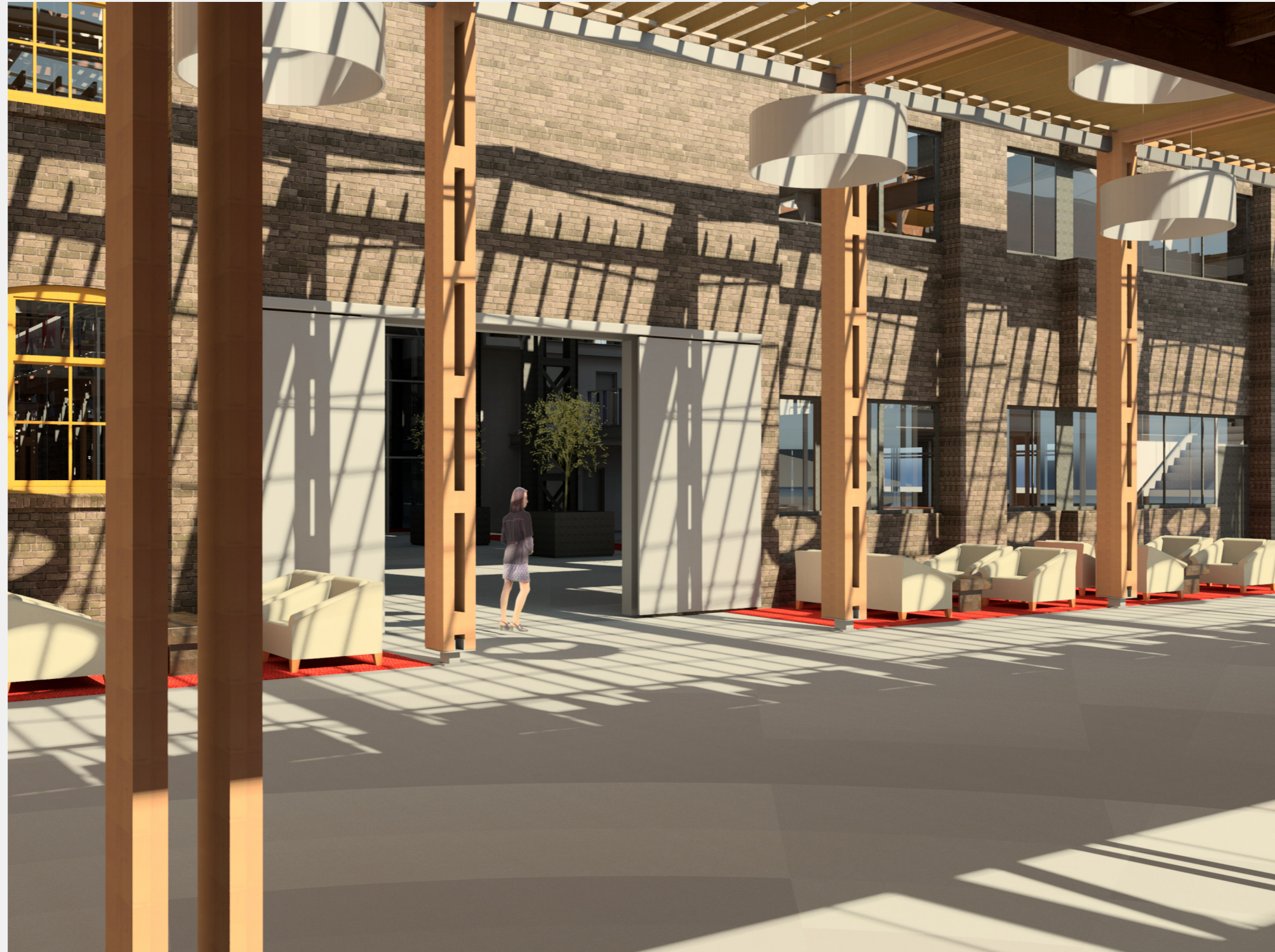

Entree van Gendthallen

Informatie en Gaderobe



Facade en Klimaat

Behoud van het ritme

Ongeïsoleerde gevel

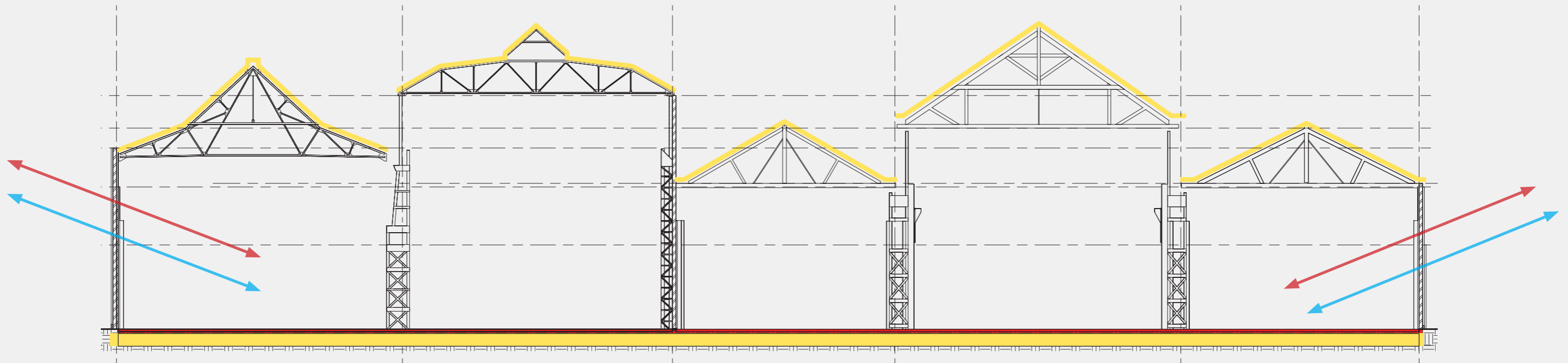

Ritme en Ventilatie

Verticale Luchtkanalen volgen het ritme

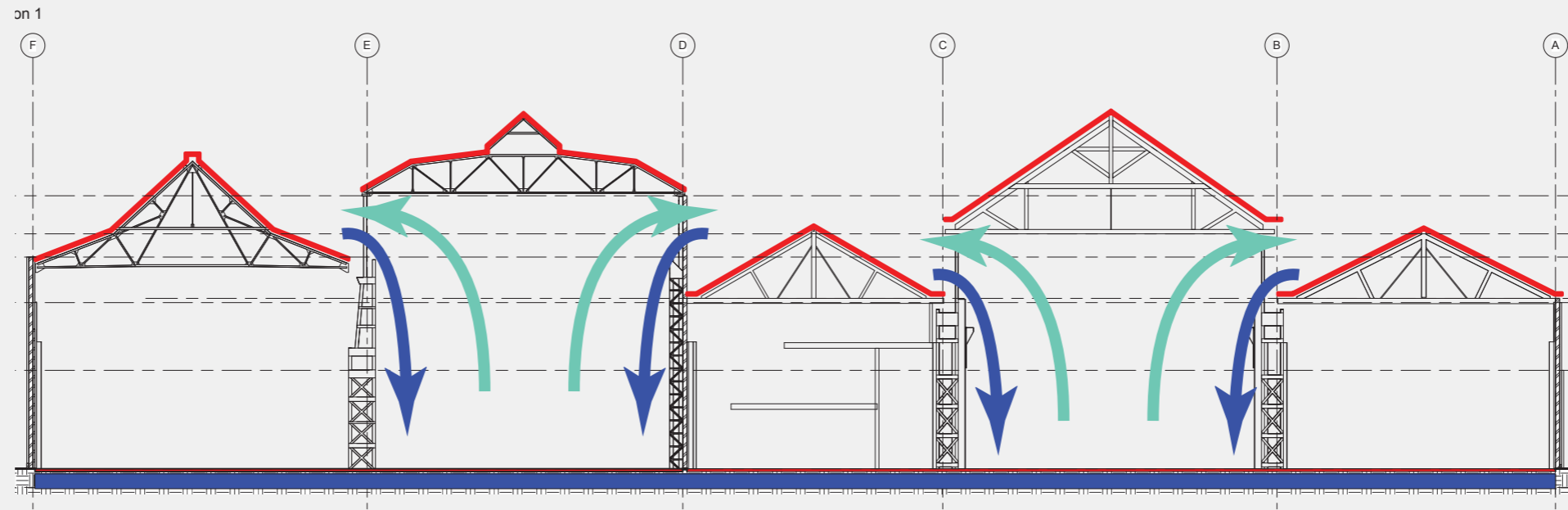

Amibtie

Akoestiek



Meubels



Vloer



Ambitie

Kunstlicht

Ambiance atmospere
Uitlichten constructie

Constuctie

Gelamineerde portalen her dimensioneren

Atmosfeer

Werkplekken
Vergaderzalen



Einde

Van Gendt redeveloping industry



P4

Industrieel erfgoed in het centrum van Amsterdam